

SEAL SPECIFICATION GUIDE

seal
specification:
001011011101100110101
001011011101100110101
001011011101100110101
001011011101100110101
001011011101100110101
001011011101100110101
001011011101100110101
001011011101100110101
001011011101100110101
001011011101100110101
001011011101100110101

SEAL SPECIFICATION GUIDE

INTRODUCTION

The Timken Company, known for its top-quality line of bearings, has extended its product line to include seals. Timken, with 77 seal patents, already had the product knowledge for seal design. In fact, it was only natural for Timken to extend this experience into a complete line of seals for the automotive aftermarket. Each and every seal sold by Timken is manufactured with the same quality that goes into every Timken bearing. To help our customers in seal selection, we have developed this Seal Specification Guide. If you have comments or suggestions on the Seal Specification Guide, please complete the postage paid card found in the back of this publication or send an e-mail to auto-am@timken.com.

HOW TO USE THIS CATALOG

The seals listed in this catalog are arranged by shaft size and part number. Determine the method you will use for your search, then turn to the corresponding section found in the table of contents. Each seal will have the dimensions, along with the seal type and material. If a specific seal is not found, contact your Timken sales representative to check the availability of that particular seal.

The data presented here is to provide a guideline or reference for general information only, it is not intended to be used for engineering purposes. Therefore, when installing any parts referenced in this catalog always follow the original equipment manufacturer's instruction manual, specifications and guidelines. The information referenced is deemed reliable but not guaranteed. The Timken Corporation reserves the right to make changes to, and amendments of, any information displayed. The Timken Corporation also reserves the right to make any functional substitutions in type, style or design where deemed appropriate.

GENERAL GUIDELINES

The data provided here is a guideline for the selection of a seal for a general or specific application. The user needs to be aware that many seal design configurations exist to meet specific requirements. Therefore, first look-up the correct seal in the Bearing and Seal Application Catalog for Automotive and Light Truck, published by The Timken Corporation. If you do not find the information regarding the seal required:

1. Determine the general category the seal application falls within.
2. Determine if operating conditions exceed the design limits.
 - a. Shaft Speed
 - b. Pressure
 - c. Eccentricity
3. Select appropriate lip, case and material. Selection is based on temperature of application, fluid and environment to be sealed or excluded.
4. Review bore and shaft configurations to ensure compatibility with seal.
5. If any questions or concerns remain, contact your Timken sales representative for more information or assistance.

WARNING

Proper maintenance and handling practices are critical. Follow the equipment manufacturer's installation instructions. Failure to follow installation instructions and to maintain proper lubrication can result in equipment failure and could lead to a risk of serious bodily harm.

© 2001 The Timken Corporation

Portions of this book are

© 2000 Freudenberg-NOK

©  GSA incorporated.

and reprinted with permission

seal
specification:
001011011101100110101
001011011101100110101

46 -DACK3
47 DREQ3
48 -DACK1
49 DREQ1

TABLE OF CONTENTS

SECTION	PAGE
Introduction.....	Inside Front Cover
How to Use This Catalog.....	Inside Front Cover
General Guidelines.....	Inside Front Cover
Warning	Inside Front Cover
Seal Nomenclature	2
Seal Design Types.....	3-4, Inside Back Cover
Shaft Recommendations.....	5
Housing Recommendations.....	6
Bore Recommendations	7
Operating Conditions	8-9
Seal Tolerances.....	10
Material Selection	11
Seal Installation	12-13
V-Seals.....	14
KWIK-Sleeve™ - Component	15
Conversion Chart.....	16
Size Section – Seals – Inch/Metric.....	17-76
Size Section – V-Seals	77-84
Size Section – Oil Bath Seals.....	85-87
Size Section – KWIK-Sleeves.....	88-93
Size Section – Seal Kits	94-97
Numeric Section – Seals-Inch	98-144
Numeric Section – Seals-Metric	145-150
Numeric Section – V-Seals	151-158
Numeric Section – Oil Bath Seals	159-161
Numeric Section – KWIK-Sleeves	162-167
Numeric Section – Seal Kits.....	168-171
Metric – Size.....	172-183
Metric – Part	184-195
O-Rings.....	196-198

SEAL NOMENCLATURE

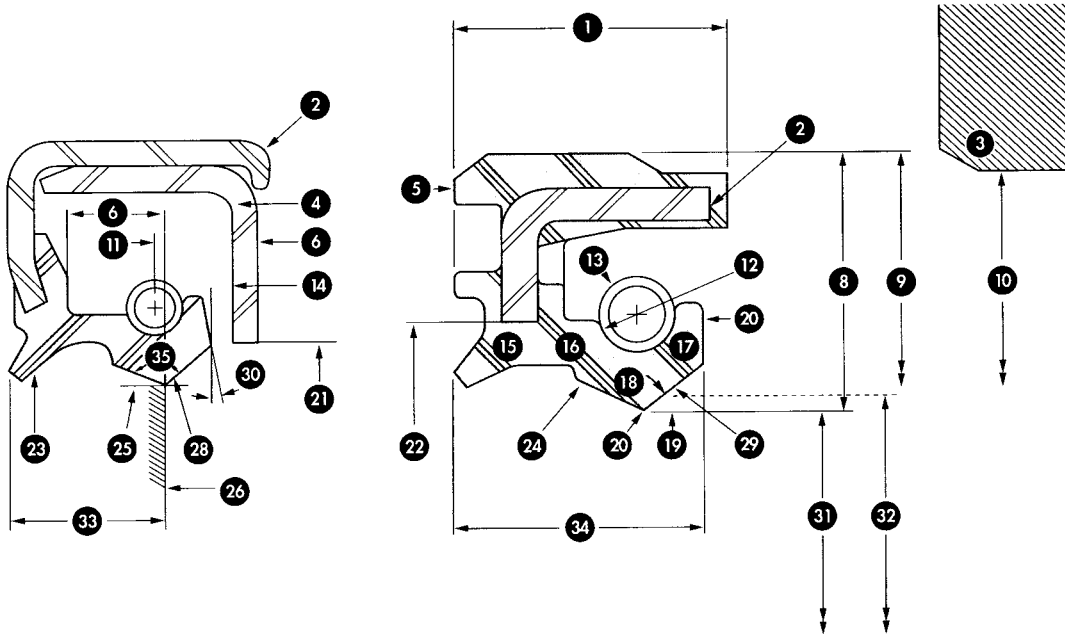

- | | |
|-------------------------------|----------------------------------|
| 1. Seal Width | 19. Inside Lip Angle |
| 2. Metal Case (Outer) | 20. Toe Face |
| 3. Housing | 21. Inside Case Inner Diameter |
| 4. Inner Case | 22. Outer Case Inner Diameter |
| 5. Outside Face | 23. Auxiliary (Dust) Lip |
| 6. Lip Length | 24. Outside Lip Surface |
| 7. Inside Face | 25. Outside Lip Angle |
| 8. Radial Wall Dimension | 26. Rib (Helix) |
| 9. Seal Outer Diameter | 27. Contact Point |
| 10. Housing Bore Diameter | 28. Static Lip |
| 11. Spring Position (R-Value) | 29. Inside Lip Surface |
| 12. Spring Groove | 30. Molded Toe Angle |
| 13. Garter Spring | 31. Spring Set Lip Diameter |
| 14. Axial Clearance | 32. Free Lip (Unsprung) Diameter |
| 15. Heel Section | 33. Contact Line Height |
| 16. Flex Section | 34. Lip Height |
| 17. Spring Retainer Lip | 35. Lip Angle |
| 18. Head Section | |

seal
specification:
001011011101100110101
001011011101100110101

x 46 -DACK3
x 47 DREQ3
x 48 -DACK1
x 49 DREQ1



SEAL DESIGN/TYPES



KEY		
METAL	RUBBER	FELT
TEFLON	LEATHER	

SEAL DESIGN TYPES (continued)



SHAFT RECOMMENDATIONS

Shafts

Seal and shaft compatibility is dependent on four conditions: shaft tolerance, lead-in chamfer, finish and hardness. Proper consideration of these conditions will assist in providing optimal seal performance.

- **SHAFT HARDNESS** is an important factor to prevent excessive wear, deformation, scratches or nicks, and to allow for easy machining for proper roughness. Under normal conditions, the seal contact area of the shaft should be Rockwell C45 minimum.
- **SHAFT SURFACE ROUGHNESS** is very important as this greatly influences the amount of lip wear. The recommended roughness is as follows:
 - Rotating 10 to 20 μ inch Ra (.25 μ M to .50 μ M Ra):
RMAX=31-126 μ inch (0.8-3.2 μ M)
 - Reciprocating 5 to 10 μ inch Ra (.13 μ M to .25 μ M Ra) The method of achieving this finish should not be overlooked.
- **PLUNGE GRINDING** is recommended for rotating shaft applications. For reciprocating applications, centerless grinding is acceptable. Rotating shaft applications require a surface with no machine lead, as machine lead may actually pump fluid from under the seal lip. Also, hard chrome plating is suggested for any cast iron or stainless steel shafts for rotating applications and for steel shafts with reciprocating applications.
- **A SHAFT CHAMFER** is suggested to assist in the installation process. Without a proper chamfer, the seal lip may be damaged or distorted resulting in a dislodged garter spring.
- **SHAFT TOLERANCE** recommendations for general applications are listed below. The tolerance range should be decreased for high speed or pressure applications.

Recommended Shaft Chamfer

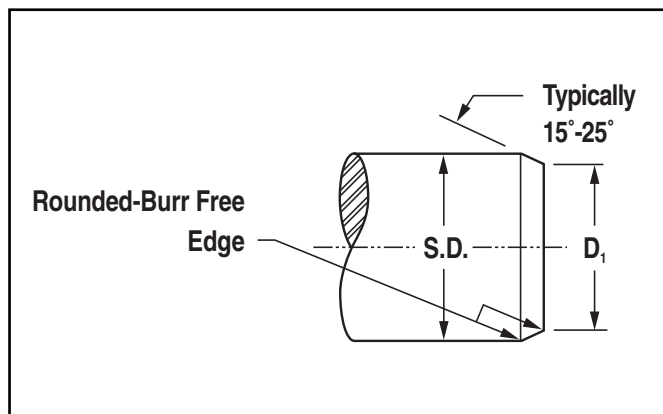

INCHES			
S.D.	D ₁	S.D.	D ₁
Up to 1.000	S.D. – .094	4.001 to 5.000	S.D. – .220
1.001 to 2.000	S.D. – .140	5.001 to 5.000	S.D. – .260
2.001 to 3.000	S.D. – .166	6.001 to 5.000	S.D. – .276
3.001 to 4.000	S.D. – .196	–	–

MILLIMETERS			
S.D.	D ₁	S.D.	D ₁
Up to 25.00	S.D. – 2.4	100.01 to 125.00	S.D. – 5.6
25.01 to 50.00	S.D. – 3.6	125.01 to 150.00	S.D. – 6.6
50.01 to 75.00	S.D. – 4.2	150.01 to 250.00	S.D. – 7.0
75.01 to 100.00	S.D. – 5.0	–	–

Recommended Shaft Tolerance

SHAFT DIAMETER (INCH)	TOLERANCE	SHAFT DIAMETER (DIN/METRIC)	TOLERANCE
Up to 4.000	±.003	Up to 100 mm	±0.08
4.001 to 6.000	±.004	100.10 to 150.00	±0.10
6.001 to 10.000	±.005	150.10 to 250.00	±0.13

HOUSING RECOMMENDATIONS

Housing

Steel and cast iron provide good surfaces for both rubber covered and metal O.D. seals. For soft alloy (aluminum) bores, rubber covered O.D. seals provide better sealing capability. In aluminum or other soft alloy bores, metal O.D. seals occasionally back out of the bore due to thermal expansion of the soft alloy. Rubber, having a higher coefficient of thermal expansion than carbon steel, will tighten in the bores as temperature rises.

Plastic or nylon are not recommended because they typically expand at a high rate causing a major problem for metal O.D. seals. If plastic is to be used, rubber O.D. seals are recommended.

Bore Chamfer

A bore chamfer is necessary to assist in installation of the seal. To the right is the recommended configuration for the chamfer.

Proper chamfer angle and depth minimizes cocking or lack of squareness of the seal to the shaft, distortion of the seal cases, and reduces assembly force.

Recommended Bore Chamfer

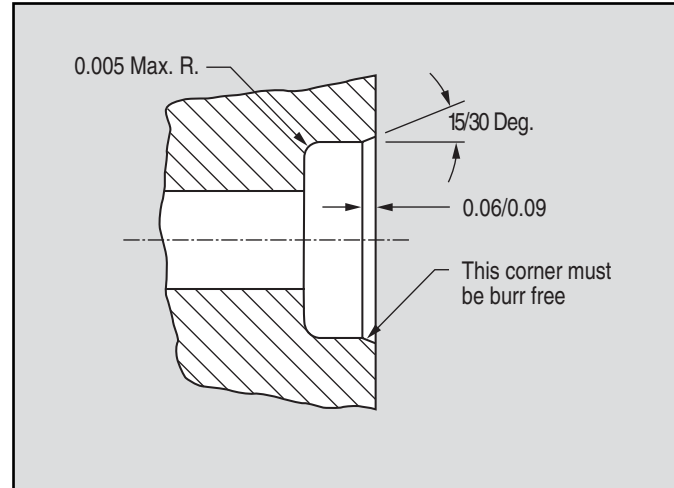

Surface Roughness

Excessively rough bore finishes may allow paths for fluid to leak between seal O.D. and bore. Below shows the recommended maximum roughness.

	METAL O.D.	RUBBER O.D.
MAXIMUM ROUGHNESS	100 μinch Ra	150 μinch Ra
	2.50 μM Ra	3.75 μM Ra
	492 μinch R _{MAX}	
	12.5 μM R _{MAX}	

The rubber O.D. seal is capable of functioning with a rougher finish.

	METAL O.D.	RUBBER O.D.
MINIMUM ROUGHNESS	None	60 μinch Ra
	None	1.5 μM Ra

A minimum bore roughness is recommended for rubber O.D. seals. This improves retention.

BORE RECOMMENDATIONS

Bore Diameter Tolerance

The recommended housing bore diameter, bore tolerance and nominal pressfit.

INCH SIZES

BORE DIAMETER	BORE TOLERANCE	NORMAL PRESS FIT		O.D. TOLERANCE (1)		OUT OF ROUND (2)	
		SEALS WITH METAL O.D.	SEALS WITH RUBBER O.D.	SEALS WITH METAL O.D.	SEALS WITH RUBBER O.D.	SEALS WITH METAL O.D.	SEALS WITH RUBBER O.D.
Up to 1.000	±.001	.004	.006	±.002	±.003	.005	.010
1.001 - 2.000	±.001	.004	.006	±.002	±.003	.006	.012
2.001 - 3.000	±.001	.004	.006	±.002	±.003	.006	.014
3.001 - 4.000	±.0015	.005	.008	±.002	±.004	.007	.018
4.001 - 6.000	±.0015	.005	.010	+0.003 -0.002	±.004	.009	.023
6.001 - 8.000	±.002	.006		+0.003 -0.002		.012	
8.001 - 9.000	±.002	.007		+0.004 -0.002		.015	
9.001 - 10.000	±.002	.008		+0.004 -0.002		.015	

EQUIVALENT METRIC SIZES

BORE DIAMETER	BORE TOLERANCE	NORMAL PRESS FIT		O.D. TOLERANCE (1)		OUT OF ROUND (2)	
		SEALS WITH METAL O.D.	SEALS WITH RUBBER O.D.	SEALS WITH METAL O.D.	SEALS WITH RUBBER O.D.	SEALS WITH METAL O.D.	SEALS WITH RUBBER O.D.
Up to 25.00	±0.025	0.10	0.15	±0.05	±0.08	0.13	0.25
25.01 - 50.00	±0.025	0.10	0.15	±0.05	±0.08	0.15	0.30
50.01 - 75.00	±0.025	0.10	0.15	±0.05	±0.08	0.15	0.36
75.01 - 100.00	±0.038	0.13	0.20	±0.05	±0.10	0.18	0.46
100.01 - 150.00	±0.038	0.13	0.25	+0.08 -0.05	±0.10	0.23	0.58
150.01 - 200.00	±0.051	0.15		+0.08 -0.05		0.30	
200.01 - 225.00	±0.051	0.18		+0.10 -0.05		0.38	
225.01 - 250.00	±0.051	0.20		+0.10 -0.05		0.38	

- (1) Seal O.D. - The average of a minimum three measurements to be taken at equally spaced positions.
- (2) Out of Round (OOR) - The maximum variance between any of the readings used in determining seal O.D.

OPERATING CONDITIONS

Seal with Spring

DESIGN LIMITATIONS

SHAFT DIAMETER	NITRILE LIP MAXIMUM CONTINUOUS SHAFT SPEED	MAXIMUM CONTINUOUS PRESSURE	MAXIMUM TOTAL ECCENTRICITY
General	3,500 rpm	5 psi	.020"
.500	7,000 rpm	5 psi	.004"
1.500	6,000 rpm	5 psi	.006"
2.500	4,000 rpm	5 psi	.010"
3.500	3,500 rpm	5 psi	.013"
4.500	2,600 rpm	5 psi	.017"

NOTE: Higher shaft speed is possible using higher temperature materials such as polyacrylate, fluoroelastomer or silicone. Slightly higher continuous pressure is possible for shaft speeds below 200 rpm. Higher eccentricity is allowable if shaft speed is reduced.

Seal without Spring

DESIGN LIMITATIONS

SHAFT DIAMETER	MAXIMUM SHAFT SPEED	MAXIMUM CONTINUOUS PRESSURE	MAXIMUM TOTAL ECCENTRICITY
General	2,000 rpm	4 psi	.005"
.500	3,500 rpm	4 psi	.003"
1.500	2,500 rpm	4 psi	.005"
2.500	2,100 rpm	4 psi	.006"
3.500	1,500 rpm	4 psi	.008"
4.500	1,200 rpm	4 psi	.010"

NOTE: Higher eccentricity is allowable if maximum shaft speed is reduced.

A nonsprung seal design offers a cost effective way to seal high viscosity grease applications. Because the design does not benefit from the constant load of a garter spring, the allowable eccentricity is decreased and the fluids to be sealed are limited.

seal
specification:
001011011101100110101
001011011101100110101

x 46 -DACK3
x 47 DREQ3
x 48 -DACK1
x 49 DREQ1



OPERATING CONDITIONS

Eccentricity

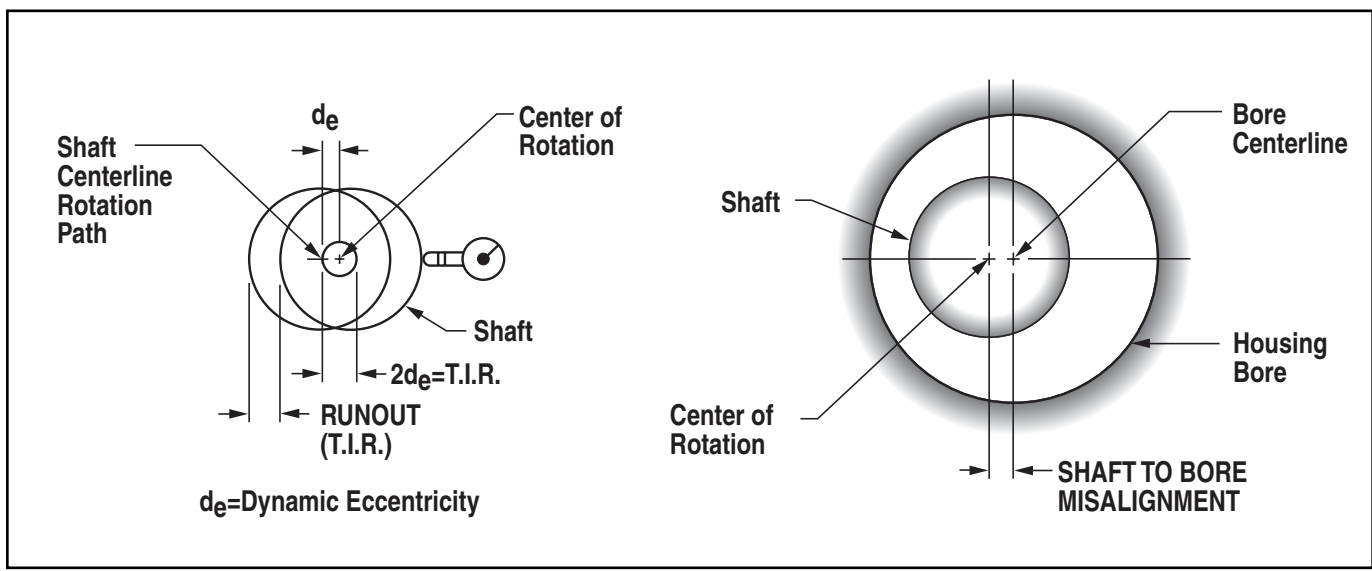

Eccentricity is determined by measuring the shaft runout, TIR and the shaft-to-bore misalignment. Combine the two results for the total eccentricity the seal lip must follow to function effectively. As eccentricity increases, and/or shaft speed increases, it becomes more difficult for the lip to follow the shaft.

SEAL TOLERANCES

To provide an interface between the seal outside surface and the housing bore surface, the recommended tolerances for the outside diameter of the seal are indicated below.

Seal width tolerance Values in millimeters

SEAL WIDTH b	TOLERANCE
b < 10	± 0.3
b > 10	± 0.4

SEAL OUTSIDE DIAMETER TOLERANCES (VALUES IN MILLIMETERS)

NOMINAL OUTSIDE DIAMETER D	DIAMETRICAL TOLERANCE		ROUNDNESS TOLERANCE ¹	
	METAL CASED	RUBBER COVERED ^{2,3}	METAL CASED	RUBBER COVERED
D < 50	+0.20 +0.08	+0.30 +0.15	0.18	0.25
50 < D _i < 80	+0.23 +0.09	+0.35 +0.20	0.25	0.35
80 < D _i < 120	+0.25 +0.10	+0.35 +0.20	0.30	0.50
120 < D _i < 180	+0.28 +0.12	+0.45 +0.25	0.40	0.65
180 < D _i < 300	+0.35 +0.15	+0.45 +0.25	0.25% of outside diameter	0.80
300 < D _i < 400	+0.45 +0.20	+0.55 +0.30	0.25% of outside diameter	1.00

- 1) The roundness tolerance is equal to the difference between the maximum diameter and the minimum diameter derived from three or more equally spaced measurements.
- 2) Rubber-covered seals having a wave profile outside surface are acceptable but will require different tolerances to be agreed upon between manufacturer and purchaser.
- 3) Rubber-covered seals employing certain materials other than nitrile may require different tolerances to be agreed upon between manufacturer and purchaser.

MATERIAL SELECTION

General Elastomer Information

BASE POLYMER	NITRILE	POLYACRYLATE	SILICONE	FLUROELASTOMER
TEMPERATURE* RANGE	-50°F ~ 250°F -45°C ~ 125°C	-20°F ~ 300°F -30°C ~ 150°C	-80°F ~ 400°F -60°C ~ 200°C	-30°F ~ 400°F -35°C ~ 200°C
Oil Resistance	l	l	n	l
Acid Resistance	n	s	s	s
Alkali Resistance	n	v	v	s
Water Resistance	n	s	n	n
Heat Resistance	n	l	l	l
Cold Resistance	n	s	n	s
Wear Resistance	l	l	n	l
Ozone Resistance	n	l	l	l

l Very good n Good for most applications s Fair, can be used if no other materials available but otherwise not recommended v Not recommended

MATERIALS	ADVANTAGES	DISADVANTAGES
NITRILE S	<ul style="list-style-type: none"> Commonly referred to as Buna-N and a Copolymer of Butadiene and Acrylonitrile Low cost Good resistance to petroleum oils, water, silicone oils, greases, glycol base fluids Good abrasion resistance, cold flow, tear resistance 	<ul style="list-style-type: none"> Poor resistance to ozone and weather aging
POLYACRYLATE N	<ul style="list-style-type: none"> Polymerised acrylic acid esters Good resistance to mineral oils, hypoid gear oils, E.P. additives, greases, aging and flex cracking Higher temperature limit than Nitrile 	<ul style="list-style-type: none"> Fair cold temperature limit Lower mechanical strength Costs slightly higher than Nitrile Poor dry running ability, water resistant
SILICONE H	<ul style="list-style-type: none"> Broad temperature range Good ozone resistance Resistant to compression set 	<ul style="list-style-type: none"> Low resistance to hydrocarbon fluids like gasoline or paraffin fluids or steam above 50 psi Cost is higher than Polyacrylate
FLUROELASTOMER V	<ul style="list-style-type: none"> Good temperature resistance Compatible with wide range of fluids Commonly chosen as high temperature replacement for Nitrile or Polyacrylate 	<ul style="list-style-type: none"> Fair resistance to water, dry running Low temperature resistance is fair Cost is high
ETHYLENE ACRYLIC (Vamac®) E	<ul style="list-style-type: none"> Good resistance to lubricating oils, greases, transmission fluids, power steering fluids and diesel fuel Higher temperature limit than NBR High/Consistent vibration damping capability 	<ul style="list-style-type: none"> Poor steam resistance Fair cold temperature limit Cost is higher than NBR
FKM & ACM BLEND X	<ul style="list-style-type: none"> Better fluids resistance than ACM Better high temperature performance than ACM 	<ul style="list-style-type: none"> Cost is higher than ACM Properties tend to be closer to ACM than FKM
FKM & VMQ BLEND Y	<ul style="list-style-type: none"> Better low temperature properties than FKM Better oil resistance than VMQ 	<ul style="list-style-type: none"> Cost is higher than VMQ Properties tend to be closer to VMQ than FKM

Felt (F) - Adequate seal for heavier lubricants, commonly used as a wiper seal.

Urethane (U) - Good lubricant resistance, good ozone resistance, good abrasion resistance

Tetrafluoro-Ethylene Propylene (Aflas®) (A) - Compatible with range of hydraulic fluids, fair abrasion resistance

P.T.F.E. (Teflon®) (T) - Low friction properties, good heat and chemical resistance

SEAL INSTALLATION PROCEDURES

The subject of installation represents an area commonly overlooked when selecting an oil seal for an application. Studies have shown this area to be one of the major causes of premature seal failure. To assist the installation, the seal should be prelubricated with grease or oil to reduce sliding friction of contact surfaces. This will also help protect the seal lips during initial run-in. An installation tool should always be

used when installing an oil seal. The use of a tool improves ease of installation and reduces the possibility of seal cocking (non-perpendicular to shaft). A hydraulic or pneumatic press is advised to supply necessary force to install the seal. Following are examples of both recommended and improper installation methods.

ACCEPTABLE METHOD OF SEAL INSTALLATION

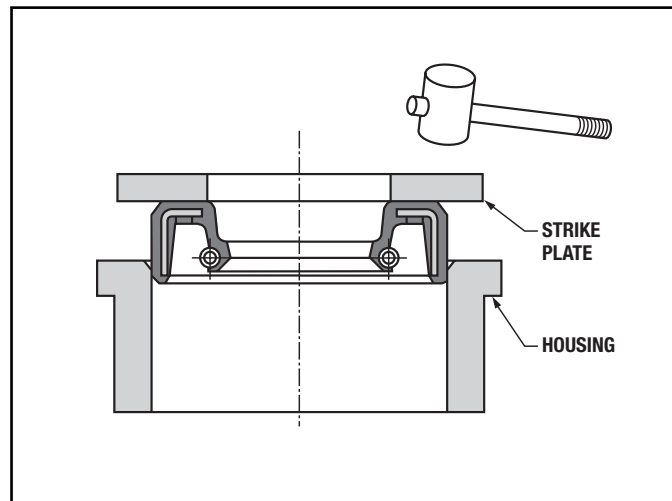
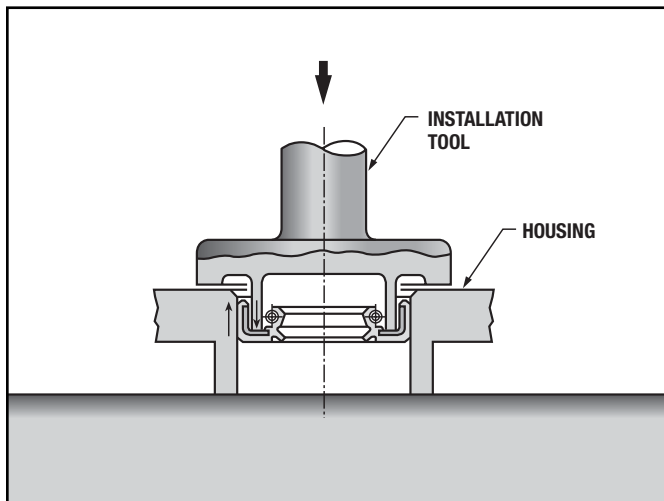
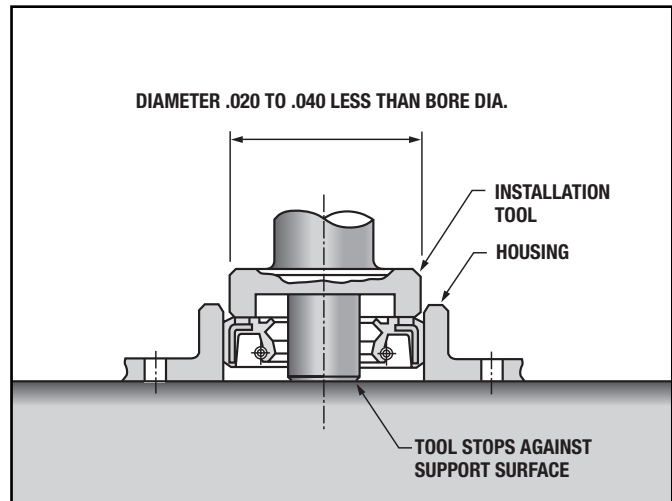
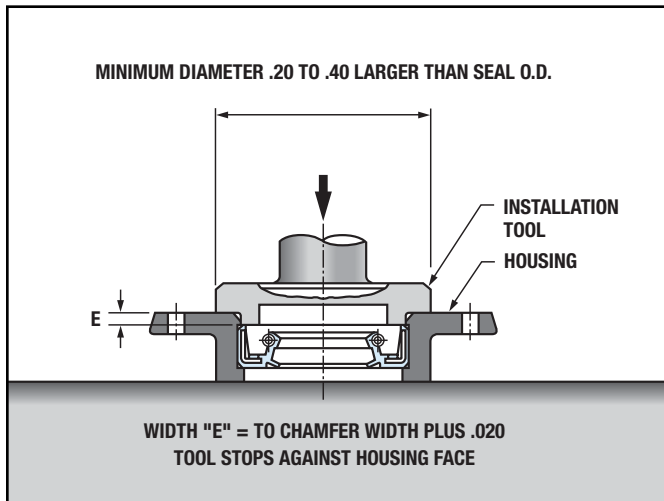

In each preferred method, installation load is absorbed by either housing or bottom plate to prevent seal damage and to assist in locating the seal properly within the bore.



IMPROPER METHOD OF SEAL INSTALLATION

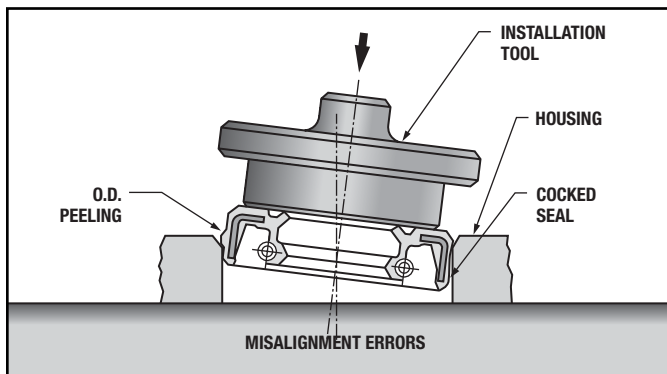
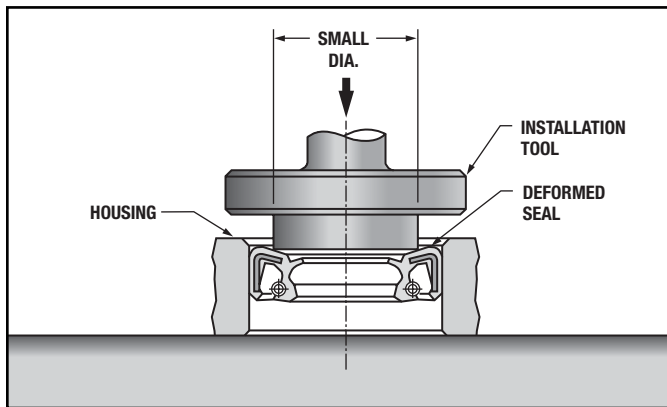
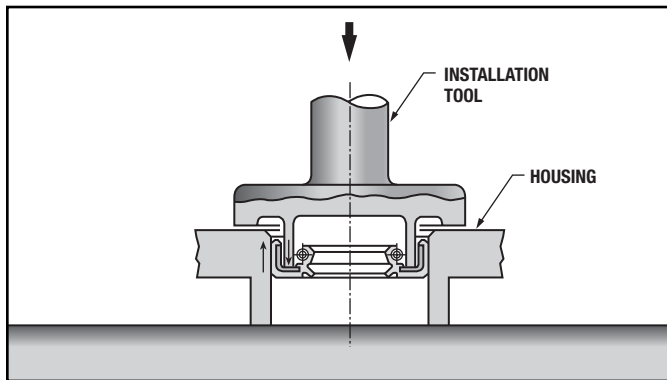
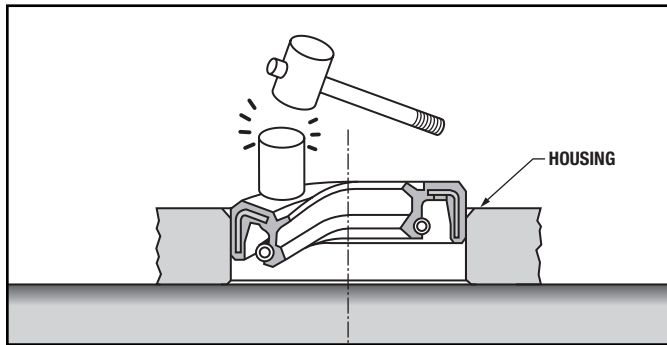

SHAFT INSTALLATION

The advisable sequence of installation is to install the seal over the shaft and then into the housing bore. Care should be exercised not to damage or deform the seal lip. The proper chamfer angle will minimize this problem. When installing over a keyway or spine, a sleeve or bullet should be employed to protect the seal lip from cuts.

Where the shaft must be installed through the seal, centering guides for the shaft will prevent lip deformation and dislodging of the spring. When possible, the shaft should be rotated as it passes through the seal to reduce sliding friction.

SEAL INSTALLATION OVER SHAFT SPLINES

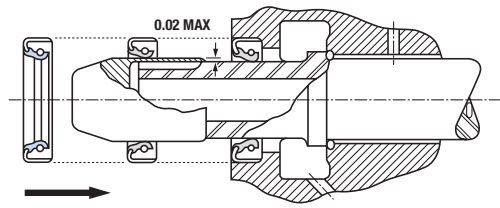

HEAVY WEIGHT HOUSING

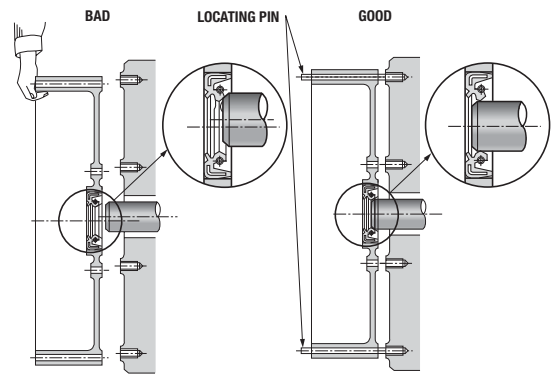

LONG SHAFT

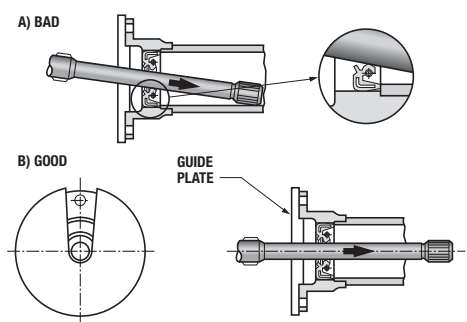

V-SEALS

V-Seals can be used on an eccentric or slightly misaligned shaft. V-Seals are extremely easy to mount. Made entirely of rubber, the V-Seals are slipped over the shaft and mounted against the counterface. Desirable for retrofitting, V-Seals can be stretched over a flange during assembly.

V-Seals reduce inventory requirements. Because of its elasticity, the same size V-Seals can be fitted to a variety of different size shafts.

Interference pressure of the seal lip against the counterface is much lower with V-Seals than with a conical seal. Less pressure means less drag and lower torque requirements from your power source.

V-Seal is manufactured using a variety of compounds which include:

Nitrile

Temperature Range:
-40° - 225° F.

Viton (Flourelastomer) – For high temperature and/or aggressive mediums

Temperature Range:

-30° - +325° F. (Dynamic Application)
-50° - +450° F. (Static Application)

V-Seals are also available in neoprene, silicon, polyacrylic and other elastomers, to meet a variety of application requirements.

V-Seals, as opposed to conventional radial seals, afford less emphasis on design, machining and axial tolerances. V-Seals will not "groove" the shaft shaving maintenance and remanufacturing costs. If properly designed, V-Seals can be used in applications demanding 5000 FPM.

V-Seals are manufactured in different profiles to suit a variety of application needs. Requirements for V-Seals are 32 to 125 RMS, depending on the particular application. Applications for V-Seals include:

Pumps	Motors
Conveyors	Gear Boxes
Mining	Machining Equipment
Pillow Blocks	Boring Boxes
Automotive	Agricultural Equipment
Steel Mills	Paper Mills
Rolling Mills	Strip Mills
Drills	Marine

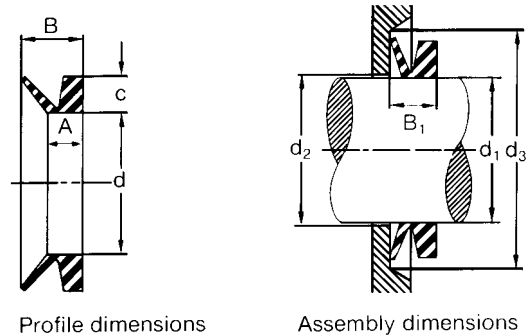

Timken Style VS1

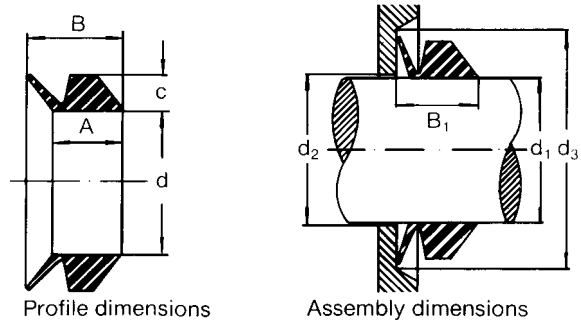

Timken Style VS2

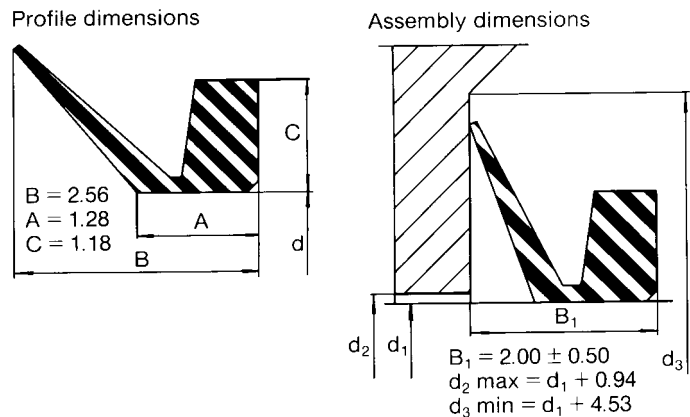

Timken Style VS3

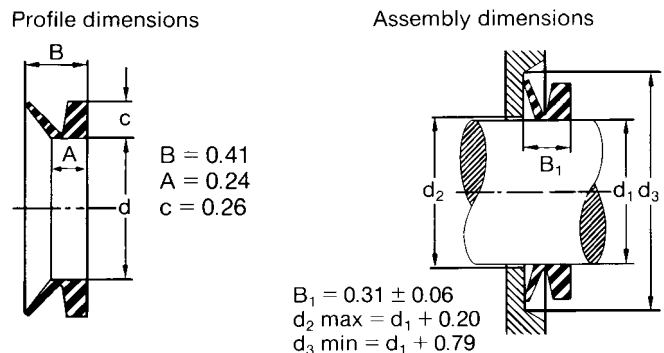

Timken Style VS4



KWIK-SLEEVE™ – COMPONENTS

Put the new technology found in KWIK- Sleeve™ – Components to work for you. Use KWIK-Sleeves to restore worn yokes and shafts, giving them new life. KWIK-Sleeves are so hard, wear resistant and friction free; it will set new standards for trouble free sleeving.

The concept of a thin wall flanged sleeve is popular for fast sleeving of shafts and yokes. However, the results often fall short of expectations. The soft sleeves lack durability and operate with too much resistance, resulting in excessive heat and failures.

KWIK-Sleeves minimize these problems and provide a long-life sleeve at an affordable price.

The innovative technology used in KWIK-Sleeves will set the new standard in the industry.

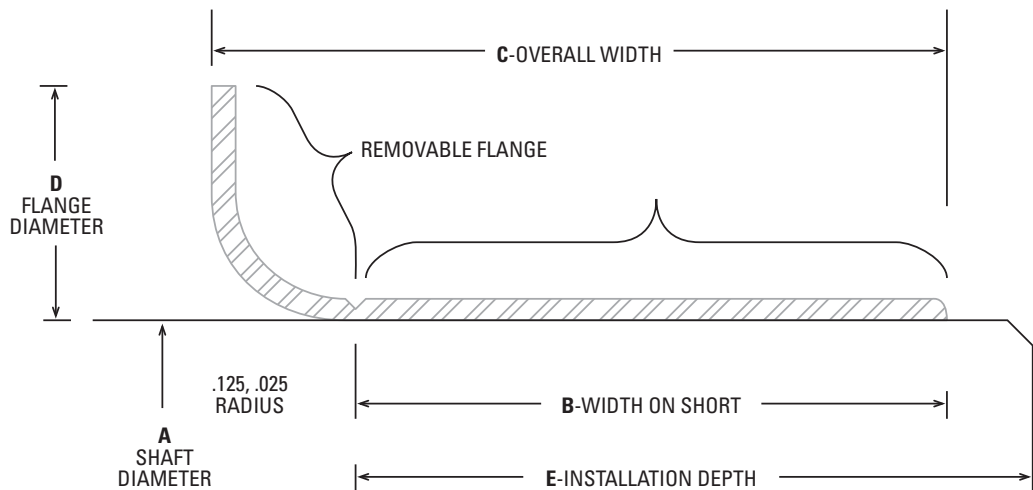

The KWIK Sleeve Difference:

Hard Chrome Coating

KWIK-Sleeves stainless steel sleeves are hard chromed for extended life.

Lower Coefficient of Friction

The stainless steel finish provides a smoother surface and has a lower coefficient of friction, reducing heat and seal wear.

Better Seal Fit

KWIK-Sleeves minimize the change to the original shaft diameter. This provides a better fit between the repaired shaft and seal.

Conversion Chart

Inch Fraction	Decimal	0	1	2	3	4	5	6	7	8	9	10	11	12
0	-	-	25.400	50.800	76.200	101.600	127.000	152.400	177.800	203.200	228.600	254.001	279.401	304.801
1/64	0.0156	0.396	25.796	51.196	76.596	101.996	127.396	152.797	178.197	203.597	228.997	254.397	279.797	305.197
1/32	0.0313	0.795	26.195	51.595	76.995	102.395	127.795	153.195	178.595	203.995	229.395	254.796	280.196	305.596
3/64	0.0469	1.191	26.591	51.991	77.391	102.791	128.192	153.592	178.992	204.392	229.792	255.192	280.592	305.992
1/16	0.0625	1.588	26.988	52.388	77.788	103.188	128.588	153.988	179.388	204.788	230.188	255.588	280.988	306.388
5/64	0.0781	1.984	27.384	52.784	78.184	103.584	128.984	154.384	179.784	205.184	230.584	255.984	281.384	306.784
3/32	0.0938	2.383	27.783	53.183	78.583	103.983	129.383	154.783	180.183	205.583	230.983	256.383	281.783	307.183
7/64	0.1094	2.779	28.179	53.579	78.979	104.379	129.779	155.179	180.579	205.979	231.379	256.779	282.179	307.579
1/8	0.1250	3.175	28.575	53.975	79.375	104.775	130.175	155.575	180.975	206.375	231.775	257.176	282.576	307.976
9/64	0.1406	3.571	28.971	54.371	79.771	105.171	130.572	155.972	181.372	206.772	232.172	257.572	282.972	308.372
5/32	0.1563	3.970	29.370	54.770	80.170	105.570	130.970	156.370	181.770	207.170	232.570	257.971	283.371	308.771
11/64	0.1719	4.366	29.766	55.166	80.566	105.966	131.367	156.767	182.167	207.567	232.967	258.367	283.767	309.167
3/16	0.1875	4.763	30.163	55.563	80.963	106.363	131.763	157.163	182.563	207.963	233.363	258.763	284.163	309.563
13/64	0.2031	5.159	30.559	55.959	81.359	106.759	132.159	157.559	182.959	208.359	233.759	259.159	284.559	309.959
7/32	0.2188	5.558	30.958	56.358	81.758	107.158	132.558	157.958	183.358	208.758	234.158	259.558	284.958	310.358
15/64	0.2344	5.954	31.354	56.754	82.154	107.554	132.954	158.354	183.754	209.154	234.554	259.954	285.354	310.754
1/4	0.2500	6.350	31.750	57.150	82.550	107.950	133.350	158.750	184.150	209.550	234.950	260.351	285.751	311.151
17/64	0.2656	6.746	32.146	57.546	82.946	108.346	133.747	159.147	184.547	209.947	235.347	260.747	286.147	311.547
9/32	0.2813	7.145	32.545	57.945	83.345	108.745	134.145	159.545	184.945	210.345	235.745	261.146	286.546	311.946
19/64	0.2969	7.541	32.941	58.341	83.741	109.141	134.542	159.942	185.342	210.742	236.142	261.542	286.942	312.342
5/16	0.3125	7.938	33.338	58.738	84.138	109.538	134.938	160.338	185.738	211.138	236.538	261.938	287.338	312.738
21/64	0.3281	8.334	33.734	59.134	84.534	109.934	135.334	160.734	186.134	211.534	236.934	262.334	287.734	313.134
11/32	0.3438	8.733	34.133	59.533	84.933	110.333	135.733	161.133	186.533	211.933	237.333	262.733	288.133	313.533
23/64	0.3594	9.129	34.529	59.929	85.329	110.729	136.129	161.529	186.929	212.329	237.729	263.129	288.529	313.929
3/8	0.3750	9.525	34.925	60.325	85.725	111.125	136.525	161.925	187.325	212.725	238.125	263.526	288.926	314.326
25/64	0.3906	9.921	35.321	60.721	86.121	111.521	136.922	162.322	187.722	213.122	238.522	263.922	289.322	314.722
13/32	0.4063	10.320	35.720	61.120	86.520	111.920	137.320	162.720	188.120	213.520	238.920	264.321	289.721	315.121
27/64	0.4219	10.716	36.116	61.516	86.916	112.316	137.717	163.117	188.517	213.917	239.317	264.717	290.117	315.517
7/16	0.4375	11.113	36.513	61.913	87.313	112.713	138.113	163.513	188.913	214.313	239.713	265.113	290.513	315.913
29/64	0.4531	11.509	36.909	62.309	87.709	113.109	138.509	163.909	189.309	214.709	240.109	265.509	290.909	316.309
15/32	0.4688	11.908	37.308	62.708	88.108	113.508	138.908	164.308	189.708	215.108	240.508	265.908	291.308	316.708
31/64	0.4844	12.304	37.704	63.104	88.504	113.904	139.304	164.704	190.104	215.504	240.904	266.304	291.704	317.104
1/2	0.5000	12.700	38.100	63.500	88.900	114.300	139.700	165.100	190.500	215.900	241.300	266.701	292.101	317.501
33/64	0.5156	13.096	38.496	63.896	89.296	114.696	140.097	165.497	190.897	216.297	241.697	267.097	292.497	317.897
17/32	0.5313	13.495	38.895	64.295	89.695	115.095	140.495	165.895	191.295	216.695	242.096	267.496	292.896	318.296
35/64	0.5469	13.891	39.291	64.691	90.091	115.491	140.892	166.292	191.692	217.092	242.492	267.892	293.292	318.692
9/16	0.5625	14.288	39.688	65.088	90.488	115.888	141.288	166.688	192.088	217.488	242.888	268.288	293.688	319.088
37/64	0.5781	14.684	40.084	65.484	90.884	116.284	141.684	167.084	192.484	217.884	243.284	268.684	294.084	319.484
19/32	0.5938	15.083	40.483	65.883	91.283	116.683	142.083	167.483	192.883	218.283	243.683	269.083	294.483	319.883
39/64	0.6094	15.479	40.879	66.279	91.679	117.079	142.479	167.879	193.279	218.679	244.079	269.479	294.879	320.279
5/8	0.6250	15.875	41.275	66.675	92.075	117.475	142.875	168.275	193.675	219.075	244.475	269.876	295.276	320.676
41/64	0.6406	16.271	41.671	67.071	92.471	117.871	143.272	168.672	194.072	219.472	244.872	270.272	295.672	321.072
21/32	0.6563	16.670	42.070	67.470	92.870	118.270	143.670	169.070	194.470	219.870	245.271	270.671	296.071	321.471
43/64	0.6719	17.066	42.466	67.866	93.266	118.666	144.067	169.467	194.867	220.267	245.667	271.067	296.467	321.867
11/16	0.6875	17.463	42.863	68.263	93.663	119.063	144.463	169.863	195.263	220.663	246.063	271.463	296.863	322.263
45/64	0.7031	17.859	43.259	68.659	94.059	119.459	144.859	170.259	195.659	221.059	246.459	271.859	297.259	322.659
23/32	0.7188	18.258	43.658	69.058	94.458	119.858	145.258	170.658	196.058	221.458	246.858	272.258	297.658	323.058
47/64	0.7344	18.654	44.054	69.454	94.854	120.254	145.654	171.054	196.454	221.854	247.254	272.654	298.054	323.454
3/4	0.7500	19.050	44.450	69.850	95.250	120.650	146.050	171.450	196.850	222.250	247.650	273.051	298.451	323.851
49/64	0.7656	19.446	44.846	70.246	95.646	121.046	146.447	171.847	197.247	222.647	248.047	273.447	298.847	324.247
25/32	0.7813	19.845	45.245	70.645	96.045	121.445	146.845	172.245	197.645	223.045	248.446	273.846	299.246	324.646
51/64	0.7969	20.241	45.641	71.041	96.441	121.842	147.242	172.642	198.042	223.442	248.842	274.242	299.642	325.042
13/16	0.8125	20.638	46.038	71.438	96.838	122.238	147.638	173.038	198.438	223.838	249.238	274.638	300.038	325.438
53/64	0.8281	21.034	46.434	71.834	97.234	122.634	148.034	173.434	198.834	224.234	249.634	275.034	300.434	325.834
27/32	0.8438	21.433	46.833	72.233	97.633	123.033	148.433	173.833	199.233	224.633	250.033	275.433	300.833	326.233
55/64	0.8594	21.829	47.229	72.629	98.029	123.429	148.829	174.229	199.629	225.029	250.429	275.829	301.229	326.629
7/8	0.8750	22.225	47.625	73.025	98.425	123.825	149.225	174.625	200.025	225.425	250.826	276.226	301.626	327.026
57/64	0.8906	22.621	48.021	73.421	98.821	124.221	149.622	175.022	200.422	225.822	251.222	276.622	302.022	327.422
29/32	0.9063	23.020	48.420	73.820	99.220	124.620	150.020	175.420	200.820	226.220	251.621	277.021	302.421	327.821
59/64	0.9219	23.416	48.816	74.216	99.616	125.017	150.417	175.817	201.217	226.617	252.017	277.417	302.817	328.217
15/16	0.9375	23.813	49.213	74.613	100.013	125.413	150.813	176.213	201.613	227.013	252.413	277.813	303.213	328.613
61/64	0.9531	24.209	49.609	75.009	100.409	125.809	151.209	176.609	202.009	227.409	252.809	278.209	303.609	329.009
31/32	0.9688	24.608	50.008	75.408	100.808	126.208	151.608	177.008	202.408	227.808	253.208	278.608	304.008	329.408
63/64	0.9844	25.004	50.404	75.804	101.204	126.604	152.004	177.404	202.804	228.204	253.604	279.004	304.404	329.804

Shaft	Bore	O.D.	Width	Part Number	Style	Matl
0.156"			5/32"			
0.156	0.500	0.504	0.187	340872	340	S
0.236"			6mm			
0.236	0.630	0.641	0.276	◆61607XX	350	S
6	16	16.28	7			
0.236	0.866	0.877	0.276	◆62207XX	350	S
6	22	22.28	7			
0.250"						
0.250	0.500	0.509	0.125	343104	340	S
0.250	0.750	0.760	0.175	240435	240	S
0.250	0.750	0.759	0.244	350435	350	S
0.276"			7mm			
0.276	0.630	0.641	0.276	◆71607XX	320	S
7	16	16.28	7			
0.276	0.866	0.877	0.276	◆72207XX	350	S
7	22	22.28	7			
0.312"			5/16"			
0.312	0.500	0.509	0.125	340826	340	S
0.312	0.625	0.635	0.175	240698	240	S
0.312	0.689	0.690	0.313	712022	#	S
0.312	0.749	0.753	0.250	712021	#	S
0.312	0.750	0.759	0.252	350364	350	S
0.312	0.999	1.003	0.375	470195	470	S
0.312	1.250	1.254	0.375	50445	50S	S
0.315"			8mm			
0.315	0.551	0.559	0.157	◆81404XX	350	S
8	14	14.20	4			
0.315	0.630	0.638	0.236	◆220860	350	S
8	16	16.20	6			
0.315	0.630	0.639	0.276	◆81607XX	350	S
8	16	16.23	7			
0.315	0.709	0.717	0.197	◆81805XX	350	S
8	18	18.20	5			
0.315	0.709	0.717	0.276	◆220818	320	S
8	18	18.20	7			
0.315	0.709	0.717	0.276	◆81807XX	320	S
8	18	18.20	7			
0.315	0.866	0.877	0.276	◆82207XX	320	S
8	22	22.20	7			
0.315	0.945	0.956	0.276	◆82407XX	350	S
8	24	24.28	7			
0.354"			9mm			
0.354	0.709	0.717	0.276	◆220918	350	S
9	18	18.20	7			

Shaft	Bore	O.D.	Width	Part Number	Style	Matl
0.354	0.709	0.717	0.276	◆91807XX	350	S
9	18	18.20	7			
0.354	0.866	0.874	0.276	◆92207XX	350	S
9	22	22.20	7			
0.354	0.945	0.956	0.276	◆92407XX	350	S
9	24	24.28	7			
0.354	1.024	1.035	0.276	◆92607XX	350	S
9	26	26.28	7			
0.375"			3/8"			
0.375	0.562	0.571	0.125	340827	340	S
0.375	0.687	0.693	0.156	311189	310	S
0.375	0.750	0.760	0.175	240385	240	S
0.375	0.750	0.756	0.250	340385	340	S
0.375	0.750	0.756	0.252	330385	330	S
0.375	0.750	0.756	0.252	50385	50S	H
0.375	0.750	0.756	0.252	50385S	50S	S
0.375	0.836	0.841	0.187	444258	440	S
0.375	0.836	0.841	0.187	474279N	470	N
0.375	0.875	0.880	0.250	473096	470	S
0.375	0.875	0.884	0.311	350156	350	S
0.375	0.999	1.004	0.250	471103	470	S
0.375	0.999	1.005	0.313	50197S	50S	S
0.394"			10mm			
0.394	0.748	0.756	0.276	◆101907XX	350	S
10	19	19.20	7			
0.394	0.748	0.757	0.276	◆221040	350	S
10	19	19.23	7			
0.394	0.866	0.877	0.276	◆102207XX	320	S
10	22	22.28	7			
0.394	0.945	0.954	0.276	◆102407XX	350	S
10	24	24.23	7			
0.394	0.984	0.995	0.276	◆102507XX	320	S
10	25	25.28	7			
0.394	1.024	1.033	0.276	◆102607XX	320	S
10	26	26.23	7			
0.408"						
0.408	1.004	1.008	0.208	4701	490	N
0.408	1.004	1.008	0.208	4701N	490	N
0.433"			11mm			
0.433	0.669	0.679	0.157	◆111704XX	320	S
11	17	17.25	4			
0.433	0.866	0.877	0.276	◆112207XX	350	S
11	22	22.28	7			
0.433	0.866	0.875	0.276	◆221122	350	S
11	22	22.23	7			
0.433	1.024	1.035	0.276	◆112607XX	350	S
11	26	26.28	7			

Shaft	Bore	O.D.	Width	Part Number	Style	Matl	Shaft	Bore	O.D.	Width	Part Number	Style	Matl
0.437" 7/16"							0.500						
0.437	0.625	0.634	0.126	343101	340	S	0.500	0.843	0.848	0.250	312196	310	S
0.437	0.875	0.885	0.175	240470	240	S	0.500	0.874	0.883	0.125	342613	340	S
0.437	0.875	0.881	0.252	472810	470	S	0.500	0.875	0.879	0.187	330699	330	S
0.437	0.875	0.881	0.252	50470S	50S	S	0.500	0.875	0.879	0.218	43080S	40S	S
0.437	0.999	1.005	0.250	50199S	50S	S	0.500	0.875	0.879	0.313	712019	#	S
0.437	0.999	1.003	0.375	470199	470	S	0.498	0.998	1.007	0.251	41442S	40S	S
0.437	1.000	1.009	0.250	6863S	350	S	0.500	0.999	1.010	0.175	240119	240	S
0.437	1.124	1.128	0.250	474277	470	S	0.500	0.999	1.005	0.252	410119	410	S
0.437	1.124	1.128	0.406	453059	450	S	0.500	0.999	1.005	0.252	470119	470	S
0.468"							0.500	0.999	1.005	0.252	471442A	470	A
0.468	1.124	1.126	0.375	470004	470	S	0.500	0.999	1.005	0.252	471442V	470	V
0.472" 12mm							0.500	1.000	1.009	0.252	450119	450	S
0.472	0.748	0.756	0.197	◆121905XX	320	S	0.500	1.003	1.009	0.250	1041	480	S
12	19	19.20	5				0.500	1.124	1.128	0.250	41526S	40S	S
0.472	0.787	0.798	0.197	◆122005XX	320	S	0.500	1.124	1.130	0.250	450005	450	S
12	20	20.28	5				0.500	1.124	1.130	0.252	470005	470	S
0.472	0.866	0.876	0.276	◆122207XX	350	S	0.500	1.124	1.128	0.252	471526	470	S
12	22	22.25	7				0.500	1.156	1.166	0.250	324112	320	S
0.472	0.866	0.876	0.276	◆221207	350	S	0.500	1.250	1.256	0.250	470014	470	S
12	22	22.25	7				0.500	1.250	1.256	0.250	471472V	470	V
0.472	0.866	0.875	0.276	◆221208	350	V	0.500	1.375	1.379	0.250	471549	470	S
12	22	22.23	7				0.500	1.375	1.379	0.312	471555	470	S
0.472	0.945	0.954	0.276	◆122407XX	320	S	0.500	1.378	1.382	0.406	472467	470	S
12	24	24.23	7				0.512" 13mm						
0.472	0.984	0.992	0.177	◆12X25045XX	320	S	0.512	0.866	0.874	0.236	◆132206XX	320	S
12	25	25.20	4.50				13	22	22.20	6			
0.472	0.984	0.994	0.276	◆122507XX	480	S	0.512	0.866	0.874	0.236	◆710348	320	S
12	25	25.25	7				13	22	22.20	6			
0.472	1.000	1.006	0.375	320457	320	S	0.512	1.024	1.031	0.276	◆132607XX	320	S
0.472	1.024	1.031	0.276	◆122607XX	320	S	13	26	26.20	7			
12	26	26.20	7				0.512	1.102	1.110	0.276	◆132807XX	320	S
0.472	1.102	1.110	0.276	◆122807XX	350	S	13	28	28.20	7			
12	28	28.20	7				0.512	1.181	1.189	0.276	◆133007XX	320	S
0.472	1.181	1.189	0.276	◆123007XX	350	S	13	30	30.20	7			
12	30	30.20	7				0.531"						
0.472	1.260	1.268	0.276	◆123207XX	350	S	0.531	1.124	1.128	0.312	471530	470	S
12	32	32.20	7				0.551" 14mm						
0.472	1.378	1.386	0.276	◆123507XX	320	S	0.551	0.945	0.954	0.236	◆221410	350	S
12	35	35.20	7				14	24	24.23	6			
0.490"							0.551	0.945	0.954	0.276	◆142407XX	350	S
0.490	0.875	0.883	0.250	340771	340	S	14	24	24.23	7			
0.490	1.122	1.132	0.265	351028	350	S	0.551	0.945	0.952	0.500	◆2004	#	S
0.500" 1/2"							14	24	24.17	12.70			
0.500	0.687	0.696	0.094	342805	340	S	0.551	0.984	0.993	0.197	◆142505XX	320	S
0.500	0.749	0.753	0.093	43095S	40S	S	14	25	25.23	5			
0.500	0.750	0.759	0.125	340847	340	S							
0.500	0.750	0.756	0.126	8792S	310	S							

Shaft	Bore	O.D.	Width	Part Number	Style	Matl
0.551 14	0.984 25	0.993 25.22	0.276 7	◆710116	320	N
0.551 14	1.000 26	1.004 26.23	0.312 7	473546	470	S
0.551 14	1.024 26	1.033 26.23	0.276 7	◆142607XX	320	S
0.551 14	1.063 27	1.071 27.20	0.276 7	◆142707XX	320	S
0.551 14	1.102 28	1.111 28.23	0.236 6	◆142806XX	350	S
0.551 14	1.181 30	1.189 30.20	0.276 7	◆143007XX	320	S
0.551 14	1.260 32	1.268 32.20	0.276 7	◆143207XX	320	S
0.551 14	1.378 35	1.387 35.22	0.276 7	◆143507XX	350	S
0.562" 9/16"						
0.562	0.750	0.754	0.094	712028	#	S
0.562	0.999	1.005	0.250	472705	470	S
0.562	1.004	1.008	0.254	718610	470	N
0.562	1.246	1.250	0.375	450536	450	S
0.562	1.250	1.254	0.250	471535	470	S
0.563" 9/16"						
0.563	0.875	0.881	0.188	314259	310	S
0.563	1.125	1.131	0.252	471281	470	S
0.563	1.378	1.384	0.252	471551	470	S
0.591" 13/22"						
15	0.000	1.102	0.276			
0.591 15	0.787 20	0.791 20.10	0.197 5	◆710346	490	S
0.591 15	0.945 24	0.954 24.23	0.276 7	◆152407XX	350	S
0.591 15	0.945 24	0.953 24.20	0.276 7	◆2027	350	S
0.591 15	0.984 25	0.992 25.20	0.197 5	◆152505XX	320	S
0.591 15	0.984 25	0.994 25.25	0.236 6	◆221510	320	N
0.591 15	0.984 25	0.992 25.20	0.276 7	◆152507XX	350	S
0.591 15	1.024 26	1.033 26.23	0.276 7	◆152607XX	350	S
0.591 15	1.102 28	1.110 28.20	0.276 7	◆152807XX	320	S
0.591 15	1.181 30	1.190 30.23	0.276 7	◆153007XX	350	S
0.591 15	1.181 30	1.190 30.23	0.276 7	◆221540	350	S
0.591 15	1.260 32	1.268 32.20	0.276 7	◆153207XX	350	S
0.591 15	1.260 32	1.269 32.22	0.315 8	◆153208XX	350	S
0.591 15	1.378 35	1.387 35.23	0.276 7	◆153507XX	350	S

Shaft	Bore	O.D.	Width	Part Number	Style	Matl
0.591 15	1.457 37	1.465 37.20	0.236 6	◆153706XX	320	S
0.591 15	1.575 40	1.583 40.20	0.276 7	◆154007XX	320	S
0.593"						
0.593	0.935	0.943	0.175	340797	340	S
0.593	1.124	1.128	0.312	471532	470	S
0.593	1.250	1.254	0.312	473405	470	S
0.593	1.375	1.379	0.312	471558	470	S
0.610"						
0.610	1.102	1.108	0.598	710274	680	V
0.614"						
0.614	0.999	1.006	0.250	340724	340	S
0.625" 5/8"						
0.625	0.812	0.821	0.094	340387	340	S
0.625	0.875	0.880	0.125	253747	250	S
0.625	0.875	0.881	0.126	340849	340	S
0.625	0.937	0.945	0.187	7399S	240	S
0.625	0.937	0.943	0.188	343105	340	S
0.625	0.999	1.005	0.252	7188S	330	S
0.625	1.000	1.006	0.125	314267N	310	N
0.625	1.000	1.009	0.252	351487	350	S
0.625	1.124	1.135	0.175	240009	240	S
0.625	1.124	1.133	0.250	340009	340	S
0.625	1.124	1.133	0.250	340009S	340	S
0.625	1.124	1.133	0.250	41466S	40S	S
0.625	1.124	1.130	0.250	450009	450	S
0.625	1.124	1.130	0.252	470009	470	S
0.625	1.124	1.128	0.252	471466	470	S
0.625	1.124	1.128	0.252	471466A	470	A
0.625	1.124	1.128	0.252	471466V	470	V
0.625	1.124	1.128	0.312	410791V	410	V
0.625	1.124	1.128	0.375	712017	#	S
0.625	1.124	1.128	0.375	712024	#	S
0.625	1.125	1.134	0.252	351466	350	S
0.625	1.181	1.185	0.350	471291V	470	V
0.625	1.250	1.254	0.250	41264S	40S	S
0.625	1.250	1.256	0.252	470018	470	S
0.625	1.250	1.259	0.252	471264	470	S
0.625	1.250	1.259	0.252	471264A	470	A
0.625	1.250	1.256	0.311	450535	450	S
0.625	1.374	1.383	0.251	351255	350	S
0.625	1.375	1.385	0.175	240023	240	S

Shaft	Bore	O.D.	Width	Part Number	Style	Matl
0.625	1.375	1.381	0.252	470023	470	S
0.625	1.375	1.381	0.252	470557	470	S
0.625	1.375	1.379	0.252	471255	470	S
0.625	1.375	1.379	0.252	471255A	470	A
0.625	1.375	1.379	0.252	471255V	470	V
0.625	1.499	1.505	0.252	471564	470	S
0.625	1.574	1.580	0.311	471612	470	S
0.625	1.624	1.628	0.312	471653	470	S
0.625	1.624	1.628	0.437	471024	470	S

0.630" 16mm

0.630	0.866	0.874	0.157	◆162204XX	320	S
16	22	22.20	4			
0.630	0.945	0.953	0.236	◆162406XX	320	S
16	24	24.20	6			
0.630	0.945	0.953	0.276	◆162407XX	320	S
16	24	24.20	7			
0.630	0.984	0.992	0.197	◆162405XX	350	S
16	25	25.20	5			
0.630	1.024	1.031	0.276	◆162607XX	320	S
16	26	26.20	7			
0.630	1.024	1.028	0.276	710243	250	S
0.630	1.063	1.071	0.551	◆221607	#	N
16	27	27.20	14			
0.630	1.072	1.076	0.354	714662	470	V
0.630	1.102	1.110	0.276	◆162807XX	350	S
16	28	28.23	7			
0.630	1.102	1.111	0.276	◆221610	320	N
16	28	28.22	7			
0.630	1.181	1.190	0.276	◆163007XX	350	S
16	30	30.23	7			
0.630	1.181	1.190	0.276	◆221620	350	S
16	30	30.23	7			
0.630	1.260	1.271	0.276	◆163207XX	320	S
16	32	32.28	7			
0.630	1.378	1.387	0.276	◆163507XX	350	S
16	35	35.23	7			
0.630	1.496	1.504	0.276	◆163807XX	320	S
16	38	38.20	7			
0.630	1.575	1.583	0.276	◆164007XX	320	S
16	40	40.20	7			
0.630	1.762	1.770	0.354	714616	#	V

0.656"

0.656	1.124	1.128	0.250	481528	480	S
0.656	1.250	1.258	0.250	340469	340	S
0.656	1.250	1.254	0.250	481537	480	S
0.656	1.376	1.382	0.250	481073	480	S
0.656	1.575	1.579	0.250	481397	480	S

0.668"

0.668	1.187	1.191	0.185	481481	480	S
-------	-------	-------	-------	--------	-----	---

Shaft	Bore	O.D.	Width	Part Number	Style	Matl
-------	------	------	-------	-------------	-------	------

0.669"

0.669	0.819	0.823	0.122	710361	440	S
0.669	0.984	0.990	0.197	◆710362	490	S
17	25	25.15	5			
0.669	1.063	1.071	0.276	◆172707XX	320	S
17	27	27.20	7			
0.669	1.102	1.111	0.276	◆172807XX	350	S
17	28	28.23	7			
0.669	1.102	1.111	0.276	◆221710	350	S
17	28	28.22	7			
0.669	1.181	1.190	0.276	◆173007XX	350	S
17	30	30.23	7			
0.669	1.181	1.190	0.276	◆221720	470	S
17	30	30.23	7			
0.669	1.260	1.269	0.276	◆173207XX	350	S
17	32	32.22	7			
0.669	1.260	1.269	0.276	◆221730	350	S
17	32	32.23	7			
0.669	1.339	1.344	0.311	◆710251	470	N
17	34	34.14	7.90			

0.669	1.378	1.385	0.276	◆173507XX	350	S
17	35	35.18	7			
0.669	1.378	1.387	0.276	◆221735	350	S
17	35	35.23	7			
0.669	1.378	1.386	0.315	◆173508XX	350	S
17	35	35.20	8			
0.669	1.457	1.465	0.276	◆173707XX	320	S
17	37	37.20	7			
0.669	1.496	1.504	0.276	◆173807XX	320	S
17	38	38.20	7			

0.669	1.575	1.584	0.276	◆174007XX	350	S
17	40	40.23	7			
0.669	1.850	1.858	0.276	◆174707XX	350	S
17	47	47.20	7			
0.669	1.850	1.858	0.315	◆174708XX	320	S
17	47	47.20	8			

0.685" 17mm

0.685	1.181	1.190	0.276	◆710344	320	S
17	30	30.23	7			

0.687" 11/16"

0.687	1.124	1.130	0.252	471529	470	S
0.687	1.187	1.191	0.187	474261	470	S
0.687	1.250	1.256	0.250	471538	470	S
0.687	1.250	1.256	0.250	481538	480	S
0.687	1.250	1.256	0.250	481538V	480	V

0.687	1.250	1.254	0.250	8773S→	250	S
0.687	1.374	1.380	0.311	450025	450	S
0.687	1.375	1.379	0.250	471553	470	S
0.687	1.375	1.379	0.406	470025	470	S
0.687	1.499	1.503	0.312	471579	470	S

0.687	1.624	1.628	0.250	471642	470	S
-------	-------	-------	-------	--------	-----	---

Shaft	Bore	O.D.	Width	Part Number	Style	Matl
0.689" 17.50mm						
0.689 17.50	1.083 27.50	1.092 27.74	0.276 7	◆710299	660	N
0.690"						
0.690	0.997	1.003	0.295	3667	2710	S
0.701"						
0.701	1.160	1.164	0.250	331173	330	S
0.709" 18mm						
0.709 18	0.906 23	0.915 23.24	0.157 4	◆710297	340	S
0.709	1.024	1.028	0.157	710222	980	S
0.709 18	1.102 28	1.111 28.22	0.236 6	◆1015	350	S
0.709 18	1.102 28	1.111 28.22	0.236 6	◆1015N	350	S
0.709 18	1.102 28	1.113 28.28	0.236 6	◆182806XX	350	S
0.709 18	1.181 30	1.185 30.10	0.264 6.70	◆3816	2710	S
0.709 18	1.181 30	1.190 30.23	0.276 7	◆183007XX	350	S
0.709 18	1.181 30	1.190 30.23	0.315 8	◆221820	320	S
0.709 18	1.260 32	1.268 32.20	0.276 7	◆183207XX	350	S
0.709 18	1.260 32	1.269 32.23	0.276 7	◆221830	350	S
0.709 18	1.260 32	1.269 32.23	0.276 7	◆710156	320	S
0.709 18	1.260 32	1.269 32.22	0.315 8	◆183208XX	350	S
0.709 18	1.339 34	1.348 34.24	0.276 7	◆710412	320	S
0.709 18	1.378 35	1.385 35.18	0.276 7	◆183507XX	320	S
0.709 18	1.457 37	1.465 37.20	0.315 8	◆183708XX	320	S
0.709 18	1.496 38	1.504 38.20	0.276 7	◆183807XX	320	S
0.709 18	1.575 40	1.583 40.22	0.276 7	◆184007XX	350	S
0.718"						
0.718	1.250	1.254	0.375	470506	470	S
0.735"						
0.735	1.248	1.252	0.250	472878	470	S

Shaft	Bore	O.D.	Width	Part Number	Style	Matl
0.736"						
0.736	1.378	1.386	0.276	710272	320	N
0.737"						
0.737	1.375	1.379	0.343	473416	470	S
0.748" 3/4" 19mm						
0.748 19	1.063 27	1.071 27.20	0.236 6	◆192706XX	350	S
0.748 19	1.181 30	1.190 30.23	0.197 5	◆221920	320	S
0.748 19	1.181 30	1.189 30.20	0.276 7	◆193007XX	320	S
0.748 19	1.260 32	1.268 32.20	0.276 7	◆193207XX	350	S
0.748 19	1.260 32	1.268 32.20	0.315 8	◆193208XX	320	S
0.748 19	1.260 32	1.269 32.23	0.315 8	◆221922	320	S
0.748 19	1.378 35	1.387 35.23	0.315 8	◆710445	350	S
0.748 19	1.378 35	1.387 35.23	0.394 10	◆193510XX	350	S
0.748 19	1.378 35	1.387 35.23	0.394 10	◆710273	350	S
0.748 19	1.417 36	1.426 36.23	0.256 6.50	◆221925	350	S
0.748 19	1.496 38	1.505 38.23	0.276 7	◆710154	320	S
0.748 19	1.575 40	1.584 40.23	0.394 10	◆194010XX	350	S
0.748 19	1.850 47	1.858 47.20	0.276 7	◆194707XX	320	S
0.750" 3/4"						
0.750	1.000	1.009	0.125	342518	340	S
0.750	1.000	1.006	0.126	240735	240	S
0.750	1.000	1.006	0.126	312518	310	S
0.750	1.000	1.006	0.126	727410	440	S
0.750	1.031	1.035	0.313	7214	490	S
0.750	1.062	1.071	0.188	240816	240	S
0.750	1.063	1.067	0.187	7929S	330	S
0.750	1.124	1.130	0.189	254270	250	S
0.750	1.124	1.133	0.189	340495	340	S
0.750	1.125	1.131	0.156	343185	340	S
0.750	1.125	1.131	0.189	1049	330	S
0.750	1.125	1.131	0.189	7750	480	S
0.750	1.250	1.254	0.250	41389S	40S	S
0.750	1.250	1.256	0.250	480954	480	S
0.750	1.250	1.256	0.250	480954V	480	V

Shaft	Bore	O.D.	Width	Part Number	Style	Matl	Shaft	Bore	O.D.	Width	Part Number	Style	Matl	
0.750	1.250	1.256	0.250	6835S	330	S	0.781	1.752	1.757	0.311	471337	470	S	
0.750	1.250	1.254	0.250	712027	#	S	0.781	1.828	1.834	0.250	450034	450	N	
0.750	1.250	1.259	0.252	350954	350	S	0.781	1.828	1.833	0.250	474273	470	S	
0.750	1.250	1.256	0.252	470141	470	S	0.781	1.828	1.832	0.437	470034	470	S	
0.750	1.250	1.256	0.252	470954	470	S	0.787"						20mm	
0.750	1.250	1.256	0.252	470954A	470	A	0.787	1.024	1.033	0.157	◆710249	970	S	
0.750	1.250	1.256	0.252	470954V	470	V	20	26	26.24	4				
0.750	1.250	1.254	0.280	2287	2740	S	0.787	1.102	1.110	0.236	◆202806XX	320	S	
0.750	1.250	1.259	0.313	350679	350	S	20	28	28.20	6				
0.750	1.250	1.256	0.374	450141	450	S	0.787	1.181	1.192	0.276	◆203007XX	350	S	
							20	30	30.28	7				
0.750	1.250	1.254	0.375	712014	#	S	0.787	1.181	1.190	0.276	◆222025	350	S	
0.750	1.302	1.306	0.250	474131	470	S	20	30	30.23	7				
0.750	1.311	1.317	0.311	252450	250	S	0.787	1.260	1.269	0.276	◆203207XX	350	S	
0.750	1.311	1.317	0.311	7013S	250	S	20	32	32.23	7				
0.750	1.312	1.316	0.250	480821	480	S								
0.750	1.375	1.379	0.250	40027S	40S	S	0.787	1.260	1.269	0.276	◆222020	350	S	
0.750	1.375	1.381	0.252	450027	450	S	20	32	32.23	7				
0.750	1.375	1.381	0.252	470027	470	S	0.787	1.339	1.348	0.276	222028	320	S	
0.750	1.375	1.381	0.252	470895	470	S	0.787	1.378	1.387	0.217	◆222030→	320	S	
0.750	1.375	1.381	0.252	471554	470	S	20	35	35.23	5.50				
							0.787	1.378	1.387	0.276	◆203507XX	350	S	
0.750	1.375	1.381	0.252	471554A	470	A	20	35	35.23	7				
0.750	1.375	1.381	0.252	471554V	470	V	0.787	1.417	1.425	0.276	◆203607XX	320	S	
0.750	1.375	1.381	0.252	7028	250	S	20	36	36.20	7				
0.750	1.375	1.379	0.406	50027S	450	S								
0.750	1.499	1.505	0.252	471567	470	S	0.787	1.417	1.426	0.276	◆222036	320	V	
							20	36	36.22	7				
0.750	1.561	1.565	0.375	450340	450	S	0.787	1.457	1.465	0.276	◆203707XX	320	S	
0.750	1.561	1.565	0.375	470340	470	S	20	37	37.20	7				
0.750	1.575	1.584	0.311	471498	470	S	0.787	1.457	1.465	0.315	◆203708XX	320	S	
0.750	1.624	1.630	0.252	470211	470	S	20	37	37.20	8				
0.750	1.624	1.630	0.252	471643	470	S	0.787	1.496	1.504	0.276	◆203807XX	320	S	
							20	38	38.20	7				
0.750	1.752	1.756	0.250	471684	470	S	0.787	1.575	1.584	0.276	◆204007XX	350	S	
0.750	1.752	1.756	0.312	471698	470	S	20	40	40.23	7				
0.750	1.828	1.832	0.375	473406	470	S	0.787	1.575	1.584	0.276	◆222050	350	S	
0.750	1.874	1.880	0.252	470390	470	S	20	40	40.23	10				
0.750	1.983	1.987	0.250	473407	470	S	0.787	1.654	1.663	0.276	◆204207XX	350	S	
							20	42	42.25	7				
0.750	2.047	2.053	0.311	472649	470	S	0.787	1.654	1.659	0.394	◆204210XX	320	S	
0.750	2.127	2.131	0.250	472538	470	S	20	42	42.15	10				
							0.787	1.850	1.859	0.276	◆204707XX	350	S	
0.762"							20	47	47.22	7				
0.762	1.160	1.164	0.250	8750	330	S								
0.762	1.160	1.164	0.250	8750S	330	S	0.787	1.850	1.859	0.276	◆222060	350	S	
							20	47	47.22	7				
0.781"							25/32"							
0.781	1.250	1.254	0.250	470601	470	S	0.787	1.850	1.859	0.335	◆710342→	320	S	
0.781	1.250	1.254	0.375	471540V	470	V	20	47	47.22	8.50				
0.781	1.375	1.381	0.252	471443	470	S	0.787	2.047	2.055	0.276	◆205207XX	350	S	
0.781	1.375	1.381	0.252	481443	480	S	20	52	52.20	7				
0.781	1.499	1.503	0.250	481568	480	S	0.796"							
							0.796	1.499	1.503	0.625	6357S	920	S	
0.781	1.624	1.628	0.250	481644	480	S								

Shaft	Bore	O.D.	Width	Part Number	Style	Matl
0.812" 13/16"						
0.812	1.250	1.254	0.254	8609	470	S
0.812	1.312	1.316	0.250	480889	480	S
0.812	1.375	1.381	0.250	353131	350	S
0.812	1.375	1.379	0.406	470204	470	S
0.812	1.499	1.503	0.250	474253	470	S
0.812	1.561	1.565	0.375	470515	470	S
0.812	1.575	1.579	0.375	450588	450	S
0.812	1.575	1.579	0.375	470588	470	S
0.812	1.624	1.628	0.250	471645	470	S
0.812	1.624	1.628	0.250	471645V	470	V
0.812	1.752	1.756	0.250	471686	470	S
0.812	1.828	1.832	0.375	473412	470	S
0.812	1.874	1.878	0.250	471729	470	S
0.813" 13/16"						
0.813	1.250	1.256	0.189	450431	450	S
0.813	1.250	1.256	0.232	471539	470	S
0.813	1.375	1.381	0.252	450204	450	S
0.813	1.375	1.381	0.252	471231	470	S
0.813	1.499	1.505	0.250	450030	450	S
0.813	1.499	1.505	0.250	470592	470	S
0.813	2.441	2.447	0.313	472950	470	S
0.827" 21mm						
0.827 21	1.378 35	1.386 35.20	0.276 7	◆213507XX	320	S
0.827 21	1.378 35	1.386 35.20	0.315 8	◆213508XX	320	S
0.843"						
0.843	1.374	1.378	0.312	472452	470	S
0.843	1.499	1.503	0.250	473413	470	S
0.843	1.624	1.628	0.250	473414	470	S
0.843	1.828	1.832	0.312	473415	470	S
0.860"						
0.860	1.437	1.441	0.250	482069N	480	N
0.866" 22mm						
0.866 22	1.260 32	1.269 32.23	0.276 7	◆222210	350	S
0.866 22	1.260 32	1.269 32.23	0.276 7	◆223207XX	350	S
0.866 22	1.378 35	1.387 35.23	0.276 7	◆222220	320	S
0.866 22	1.378 35	1.387 35.23	0.276 7	◆223507XX	350	S

Shaft	Bore	O.D.	Width	Part Number	Style	Matl
0.866 22	1.417 36	1.425 36.20	0.276 7	◆223607XX	320	S
0.866 22	1.457 37	1.466 37.23	0.276 7	◆223707XX	350	S
0.866 22	1.496 38	1.504 38.20	0.276 7	◆223807XX	350	S
0.866 22	1.496 38	1.504 38.20	0.315 8	◆222238	320	S
0.866 22	1.496 38	1.504 38.20	0.315 8	◆223808XX	320	S
0.866 22	1.575 40	1.581 40.16	0.276 7	◆1963	350	N
0.866 22	1.575 40	1.584 40.23	0.276 7	◆222240	350	S
0.866 22	1.575 40	1.584 40.23	0.276 7	◆224007XX	350	S
0.866 22	1.575 40	1.583 40.20	0.315 8	◆224008XX	350	S
0.866 22	1.575 40	1.584 40.23	0.354 9	◆222242	320	N
0.866 22	1.654 42	1.661 42.20	0.276 7	◆224207XX	320	S
0.866 22	1.654 42	1.661 42.20	0.394 10	◆224210XX	350	S
0.866 22	1.772 45	1.781 45.23	0.276 7	◆224507XX	350	S
0.866 22	1.772 45	1.781 45.24	0.315 8	◆222267←	320	H
0.866 22	1.850 47	1.859 47.23	0.276 7	◆224707XX	350	S
0.874" 7/8"						
0.874	1.125	1.131	0.125	240733	240	S
0.874	1.250	1.259	0.251	340483	340	S
0.875" 7/8"						
0.875	1.187	1.196	0.188	340850	340	S
0.875	1.245	1.256	0.187	5976S	340	S
0.875	1.250	1.256	0.181	7840S	310	S
0.875	1.250	1.256	0.189	254287	250	S
0.875	1.250	1.254	0.250	42280S	40S	S
0.875	1.255	1.261	0.181	7014S	40S	S
0.875	1.308	1.317	0.250	340413	340	S
0.875	1.308	1.317	0.250	353132	350	S
0.875	1.375	1.379	0.187	440131	440	S
0.875	1.375	1.381	0.250	321267	320	S
0.875	1.375	1.381	0.250	41267S	40S	S
0.875	1.375	1.379	0.250	712015	#	V
0.875	1.375	1.384	0.252	350567	350	S
0.875	1.375	1.384	0.252	351267	350	S
0.875	1.375	1.381	0.252	470398	470	S
0.875	1.375	1.381	0.252	470567	470	S
0.875	1.375	1.381	0.252	470567N	470	N
0.875	1.375	1.381	0.252	471267	470	S

Shaft	Bore	O.D.	Width	Part Number	Style	Matl
0.875	1.375	1.381	0.252	471267A	470	A
0.875	1.375	1.381	0.252	471267T	470	T
0.875	1.375	1.381	0.252	471267V	470	V
0.875	1.375	1.379	0.312	38832	940	T
0.875	1.436	1.441	0.256	712270	480	S
0.875	1.499	1.503	0.250	471570	470	S
0.875	1.499	1.503	0.250	471570V	470	V
0.875	1.499	1.505	0.252	40059S	40S	S
0.875	1.500	1.506	0.311	470032	470	S
0.875	1.500	1.506	0.311	470680	470	S
0.875	1.500	1.506	0.313	450032	450	S
0.875	1.500	1.506	0.313	450680	450	S
0.875	1.575	1.581	0.250	350877	350	S
0.875	1.577	1.581	0.250	471633	470	S
0.875	1.624	1.634	0.187	240215	240	S
0.875	1.624	1.630	0.250	351646	350	S
0.875	1.624	1.630	0.252	470215	470	S
0.875	1.624	1.630	0.252	471646	470	S
0.875	1.752	1.758	0.252	470590	470	S
0.875	1.828	1.833	0.252	471137	470	S
0.875	1.875	1.881	0.252	471730	470	S
0.875	2.000	2.004	0.437	450645	450	S
0.875	2.000	2.004	0.437	470645	470	S
0.905"						
0.905	1.260	1.268	0.197	222310	340	S
0.906" 23mm						
0.906	1.252	1.261	0.217	◆710254	340	S
23	31.80	32.03	5.50			
0.906	1.339	1.348	0.315	◆222330←	320	N
23	34	34.24	8			
0.906	1.499	1.503	0.390	470207	470	S
0.906	1.828	1.832	0.437	450038	450	S
0.937" 15/16"						
0.937	1.375	1.383	0.250	340787	340	S
0.937	1.375	1.381	0.252	471015	470	S
0.937	1.499	1.503	0.250	471571	470	S
0.937	1.499	1.503	0.250	471571V	470	V
0.937	1.499	1.503	0.250	481571V	480	V
0.937	1.624	1.628	0.250	471647	470	S
0.937	1.750	1.756	0.311	472951	470	S
0.937	1.752	1.756	0.250	474252	470	S
0.937	1.828	1.832	0.437	470039	470	S
0.938" 15/16"						
0.938	1.828	1.834	0.438	450039	450	S

Shaft	Bore	O.D.	Width	Part Number	Style	Matl
0.945" 24mm						
0.945	1.378	1.387	0.276	◆222410	350	S
24	35	35.23	7			
0.945	1.378	1.387	0.276	◆243507XX	350	S
24	35	35.23	7			
0.945	1.457	1.466	0.276	◆243707XX	350	S
24	37	37.23	7			
0.945	1.496	1.504	0.276	◆243807XX	320	S
24	38	38.20	7			
0.945	1.575	1.584	0.276	◆222430	350	S
24	40	40.23	7			
0.945	1.575	1.584	0.276	◆244007XX	350	S
24	40	40.23	7			
0.945	1.645	1.661	0.276	◆244207XX	320	S
24	42	42.20	7			
0.945	1.654	1.663	0.394	◆244210XX	320	S
24	42	42.25	10			
0.945	1.693	1.702	0.315	222450	250	S
0.945	1.850	1.859	0.276	◆244707XX	350	S
24	47	47.23	7			
0.945	2.047	2.055	0.276	◆245207XX	320	S
24	52	52.20	7			
0.968"						
0.968	1.499	1.503	0.250	40208	40S	S
0.968	1.499	1.503	0.312	451583	450	S
0.968	1.575	1.579	0.375	450545	450	S
0.968	1.624	1.628	0.250	471648	470	S
0.968	1.686	1.690	0.312	8059S	250	S
0.968	1.752	1.756	0.250	471688	470	S
0.968	1.850	1.854	0.375	482309	480	S
0.968	1.874	1.878	0.437	451082	450	S
0.968	2.048	2.052	0.375	482310	480	S
0.968	2.062	2.066	0.437	450339	450	S
0.968	2.440	2.445	0.375	472238	470	S
0.980"						
0.980	1.500	1.506	0.252	472324	470	S
0.984"						
25	35	35.20	6			
0.984	1.378	1.383	0.276	◆222510	350	S
25	35	35.13	7			
0.984	1.378	1.388	0.276	◆253506XX	320	S
25	35	35.25	7			
0.984	1.378	1.388	0.276	◆712007	480	V
25	35	35.25	7			
0.984	1.417	1.426	0.276	◆253607XX	320	S
25	36	36.23	7			
0.984	1.417	1.426	0.315	◆253608XX	350	S
25	36	36.22	8			

Shaft	Bore	O.D.	Width	Part Number	Style	Matl	Shaft	Bore	O.D.	Width	Part Number	Style	Matl
0.984 25	1.457 37	1.465 37.20	0.276 7	◆253707XX	320	S	1.000" 1"						
0.984 25	1.496 38	1.505 38.23	0.276 7	◆222535→	320	S							
0.984 25	1.496 38	1.505 38.23	0.276 7	◆253807XX	350	S	1.000	1.247	1.253	0.187	343098	340	S
0.984	1.499	1.504	0.250	4458V	#	V	1.000	1.250	1.256	0.126	240731	240	S
0.980	1.500	1.506	0.252	472324A	470	A	1.000	1.250	1.254	0.536	6847S	#	S
0.980	1.500	1.506	0.252	472324V	470	V	1.000	1.312	1.318	0.126	342517	340	S
0.984	1.500	1.508	0.410	6522S	340	S	1.000	1.375	1.381	0.189	2064	330	S
0.984 25	1.575 40	1.584 40.23	0.276 7	◆222540	470	S	1.000	1.375	1.381	0.189	441130	440	S
0.984 25	1.575 40	1.583 40.22	0.276 7	◆254007XX	350	S	1.000	1.375	1.379	0.250	712026	#	S
0.984 25	1.575 40	1.583 40.22	0.276 7	◆254007XX	350	S	1.000	1.375	1.381	0.252	252277	250	S
0.984 25	1.575 40	1.583 40.22	0.276 7	◆254007XX	350	S	1.000	1.437	1.447	0.187	240414	240	S
0.984 25	1.575 40	1.583 40.22	0.276 7	◆254007XX	350	S	1.000	1.437	1.441	0.250	330414	330	S
0.984 25	1.575 40	1.583 40.23	0.276 8	710307	320	N	1.000	1.437	1.441	0.250	39910	TW	T
0.984 25	1.575 40	1.584 40.23	0.315 8	◆710316→	320	S	1.000	1.437	1.441	0.250	472311	470	S
0.984	1.596	1.600	0.250	712018	#	S	1.000	1.437	1.441	0.250	472311V	470	V
0.984	1.614	1.618	0.315	39867	TW-H	T	1.000	1.437	1.443	0.252	350414	350	S
0.984 25	1.654 42	1.661 42.20	0.236 6	◆254206XX	350	S	1.000	1.438	1.444	0.250	42311S	40S	S
0.984 25	1.654 42	1.665 42.20	0.315 8	222556→	320	H	1.000	1.499	1.503	0.250	41224S	40S	S
0.984 25	1.654 42	1.661 42.20	0.315 8	◆254208XX	320	S	1.000	1.499	1.503	0.250	481224V	480	V
0.984 25	1.654 42	1.665 42.28	0.394 10	◆254210XX	350	S	1.000	1.499	1.503	0.250	712016	#	S
0.984 25	1.654 42	1.665 42.28	0.394 10	◆254210XX	350	S	1.000	1.499	1.505	0.252	471224	470	S
0.984	1.752	1.756	0.313	712012	#	V	1.000	1.499	1.505	0.252	471224A	470	A
0.984 25	1.772 45	1.781 45.23	0.315 8	◆254508XX	350	S	1.000	1.499	1.505	0.252	471224V	470	V
0.984 25	1.772 45	1.781 45.23	0.315 8	◆254508XX	350	S	1.000	1.499	1.503	0.312	5857	290	F
0.984 25	1.811 46	1.819 46.20	0.276 7	◆254607XX	320	S	1.000	1.499	1.503	0.390	450120	450	S
0.984 25	1.811 46	1.819 46.20	0.276 7	◆254607XX	320	S	1.000	1.500	1.509	0.252	340120	340	S
0.984	1.828	1.838	0.187	240457	240	S	1.000	1.500	1.509	0.311	350909	350	S
0.984	1.828	1.832	0.437	450457	450	S	1.000	1.500	1.506	0.311	450553	450	S
0.984 25	1.850 47	1.859 47.22	0.276 7	◆222560	350	S	1.000	1.500	1.506	0.311	470120	470	S
0.984 25	1.850 47	1.859 47.23	0.276 7	◆254707XX	350	S	1.000	1.500	1.506	0.311	470553	470	S
0.984 25	1.850 47	1.859 47.23	0.276 7	◆254707XX	350	S	1.000	1.561	1.565	0.250	471270	470	S
0.984 25	1.850 47	1.859 47.23	0.276 7	◆254707XX	350	S	1.000	1.563	1.569	0.187	343123	340	S
0.984 25	1.890 48	1.898 48.20	0.315 8	◆254808XX	320	S	1.000	1.575	1.579	0.250	473380	470	S
0.984 25	1.890 48	1.898 48.20	0.315 8	◆254808XX	320	S	1.000	1.624	1.630	0.250	471649	470	S
0.984 25	1.969 50	1.980 50.28	0.394 10	◆255010XX	350	S	1.000	1.624	1.630	0.250	471649A	470	A
0.984 25	2.047 52	2.058 52.27	0.276 7	◆255207XX	350	S	1.000	1.624	1.630	0.250	471649V	470	V
0.984 25	2.047 52	2.055 52.20	0.315 8	◆255208XX	350	S	1.000	1.624	1.630	0.311	470219	470	S
0.984 25	2.047 52	2.055 52.20	0.315 8	◆255208XX	350	S	1.000	1.624	1.630	0.375	450219	450	S
0.984 25	2.047 52	2.055 52.20	0.394 10	◆255210XX	350	S	1.000	1.686	1.692	0.250	474250	470	S
0.984 25	2.047 52	2.055 52.20	0.394 10	◆255210XX	350	S	1.000	1.689	1.695	0.252	471465	470	S
0.984	2.062	2.066	0.437	450693	450	S	1.000	1.752	1.756	0.250	40230S	40S	S
0.984 25	2.441 62	2.452 62.28	0.394 10	◆222580	320	S	1.000	1.752	1.758	0.252	470230	470	S
0.984 25	2.441 62	2.452 62.28	0.394 10	◆256210XX	320	S	1.000	1.752	1.758	0.252	470541	470	S
0.984 25	2.441 62	2.452 62.28	0.394 10	◆256210XX	320	S	1.000	1.752	1.758	0.252	471689	470	S
0.984 25	2.441 62	2.452 62.28	0.394 10	◆256210XX	320	S	1.000	1.752	1.758	0.252	471689A	470	A
0.984 25	2.441 62	2.452 62.28	0.394 10	◆256210XX	320	S	1.000	1.752	1.758	0.252	471689V	470	V
0.984 25	2.441 62	2.452 62.28	0.394 10	◆256210XX	320	S	1.000	1.752	1.756	0.313	712013	#	S
0.987	1.282	1.288	0.438	450040	450	S	1.000	1.780	1.785	0.468	203005	2030	S
0.987	1.282	1.288	0.438	450040	450	S	1.000	1.780	1.785	0.468	203005S	203	S

0.987"

Shaft	Bore	O.D.	Width	Part Number	Style	Matl
1.000	1.780	1.785	0.468	205005	2050	F
1.000	1.781	1.787	0.469	204005	2040	S
1.000	1.781	1.787	0.469	204005S	2040	S
<hr/>						
1.000	1.828	1.834	0.295	450593	450	S
1.000	1.828	1.832	0.296	470593	470	S
1.000	1.828	1.832	0.437	470041	470	S
1.000	1.874	1.880	0.252	471733	470	S
1.000	1.936	1.948	0.187	240462	240	S
<hr/>						
1.000	1.983	1.987	0.250	471744	470	S
1.000	2.000	2.011	0.252	40157S	40S	S
1.000	2.000	2.006	0.252	471760	470	S
1.000	2.000	2.006	0.252	471760A	470	A
1.000	2.000	2.006	0.252	471760V	470	V
<hr/>						
1.000	2.047	2.051	0.312	472138	470	S
1.000	2.062	2.066	0.250	471619	470	S
1.000	2.062	2.066	0.375	453165	450	S
1.000	2.441	2.447	0.375	321516	320	S
1.000	2.441	2.445	0.375	471516	470	S
<hr/>						
1.000	2.533	2.537	0.250	472539	470	S
<hr/>						
1.004"			1"			
1.004	1.516	1.525	0.335	710303	350	S
<hr/>						
1.024"			26mm			
1.024	1.457	1.465	0.276	◆263707XX	320	S
26	37	37.20	7			
1.024	1.496	1.504	0.197	◆263805XX	320	S
26	38	38.20	5			
1.024	1.496	1.504	0.315	222630	320	N
1.024	1.575	1.583	0.276	◆264007XX	320	S
26	40	40.20	7			
1.024	1.654	1.661	0.276	◆264207XX	320	S
26	42	42.20	7			
<hr/>						
1.024	1.654	1.659	0.315	◆223606	480	S
26	42	42.14	8			
1.024	1.654	1.661	0.315	710399→	320	S
1.024	1.654	1.663	0.394	◆264210XX	350	S
26	42	42.23	10			
1.024	1.732	1.740	0.315	710153	#	S
1.024	1.850	1.859	0.276	◆264707XX	350	S
26	47	47.23	7			
<hr/>						
1.024	1.890	1.899	0.276	◆222655→	320	S
26	48	48.24	7			
1.024	1.890	1.899	0.276	◆264807XX	320	S
26	48	48.23	7			
1.024	2.047	2.055	0.315	◆265208XX	320	S
26	52	52.20	8			
<hr/>						
1.031"						
1.031	1.499	1.503	0.390	50209	50S	S
1.031	1.575	1.584	0.311	471076	470	S

Shaft	Bore	O.D.	Width	Part Number	Style	Matl
1.031	1.575	1.584	0.311	471076V	470	V
1.031	1.624	1.628	0.250	481650	480	S
<hr/>						
1.047"						
1.047	1.811	1.815	0.285	710053	480	S
<hr/>						
1.055"						
1.055	1.499	1.500	0.268	480210	480	S
<hr/>						
1.062"			1 1/16"			
1.062	1.499	1.507	0.250	340210	340	S
1.062	1.575	1.581	0.250	3732S	480	S
1.062	1.624	1.633	0.251	471651	470	S
1.062	1.752	1.756	0.312	471705	470	S
1.062	1.828	1.832	0.375	473419	470	S
<hr/>						
1.062	1.874	1.878	0.250	471735	470	S
1.062	1.983	1.987	0.437	450342	450	S
1.062	1.983	1.987	0.437	470342	470	S
1.062	2.000	2.004	0.375	471772	470	S
1.062	2.062	2.066	0.375	473420	470	S
<hr/>						
1.063	2.835	2.841	0.374	472953V	470	V
<hr/>						
1.063"			1 1/16"		27mm	
1.063	1.457	1.463	0.276	◆273707XX	350	S
27	37	37.15	7			
1.063	1.561	1.567	0.250	450188	450	S
1.063	1.575	1.583	0.315	712009	320	V
1.063	1.654	1.657	0.276	222742	480	V
1.063	1.654	1.663	0.394	◆274210XX	350	S
27	42	42.23	10			
<hr/>						
1.063	1.686	1.691	0.313	470606	470	S
1.063	1.693	1.702	0.276	◆710157→	320	S
27	43	43.23	7			
1.063	1.693	1.701	0.315	◆274308XX	320	S
27	43	43.20	8			
1.063	1.693	1.702	0.354	◆1990→	320	N
27	43	43.23	9			
1.063	1.693	1.701	0.354	◆222743←	320	H
27	43	43.20	9			
<hr/>						
1.063	1.772	1.781	0.315	◆274508XX	350	S
27	45	45.25	8			
1.063	1.772	1.781	0.354	◆222745←	320	N
27	45	45.24	9			
1.063	1.828	1.834	0.250	450043	450	S
1.063	1.850	1.859	0.394	◆274710XX	350	S
27	47	47.23	10			
1.063	2.000	2.006	0.250	471762	470	S
<hr/>						
1.063	2.047	2.055	0.315	◆275208XX	350	S
27	52	52.20	8			
1.063	2.835	2.841	0.374	472953	470	S

Shaft	Bore	O.D.	Width	Part Number	Style	Matl
1.093"						
1.093	1.828	1.832	0.437	450044	450	S
1.093	2.000	2.004	0.437	450159	450	S
1.100"						
1.100	1.572	1.578	0.308	2503→	480	N
1.100	1.572	1.578	0.308	2503N→	480	N
1.102" 28mm						
1.102 28	1.496 38	1.505 38.23	0.276 7	◆283807XX	350	S
1.102	1.496	1.506	0.276	712104→	TPDW	T
1.102 28	1.496 38	1.505 38.23	0.394 10	◆710347←	320	S
1.102 28	1.575 40	1.584 40.23	0.276 7	◆222820	330	S
1.102 28	1.575 40	1.585 40.26	0.276 7	◆284007XX	350	S
1.102 28	1.575 40	1.583 40.20	0.315 8	◆284008XX	320	S
1.102 28	1.575 40	1.584 40.23	0.315 8	◆710325→	320	S
1.102 28	1.614 41	1.625 41.27	0.276 7	◆222830	320	N
1.102	1.614	1.618	0.315	39869	#	T
1.102 28	1.654 42	1.663 42.23	0.315 8	◆284208XX	350	S
1.102 28	1.654 42	1.663 42.24	0.315 8	◆712008←	320	H
1.102	1.673	1.682	0.315	710216	350	S
1.102	1.693	1.702	0.315	710119	320	N
1.102 28	1.732 44	1.741 44.22	0.236 6	◆222835	320	N
1.102 28	1.732 44	1.741 44.23	0.236 6	◆284406XX	320	N
1.102 28	1.772 45	1.780 45.20	0.315 8	◆284508XX	320	S
1.102 28	1.850 47	1.859 47.22	0.276 7	◆284707XX	350	S
1.102 28	1.850 47	1.859 47.22	0.315 8	◆222860→	320	N
1.102 28	1.890 48	1.898 48.20	0.315 8	◆284808XX	320	S
1.102 28	2.047 52	2.056 52.23	0.276 7	◆285207XX	350	S
1.102	2.087	2.091	0.378	710433	#	S
1.125" 1 1/8"						
1.125	1.374	1.383	0.125	340835	340	S
1.125	1.438	1.444	0.215	313842	310	S
1.125	1.500	1.504	0.250	1037	350	S
1.125	1.500	1.509	0.250	340815	340	S

Shaft	Bore	O.D.	Width	Part Number	Style	Matl
1.125	1.502	1.506	0.250	312140	310	S
1.125	1.561	1.572	0.187	240151	240	S
1.125	1.561	1.567	0.250	340151	340	S
1.125	1.561	1.567	0.250	352560	350	S
1.125	1.561	1.567	0.250	472560N	470	N
1.125	1.561	1.567	0.250	7941	440	S
1.125	1.563	1.569	0.252	50151S	50S	S
1.125	1.564	1.568	0.250	43072S	40S	S
1.125	1.624	1.628	0.190	3638→	480	N
1.125	1.624	1.628	0.250	481652V	480	V
1.125	1.624	1.630	0.252	471100	470	S
1.125	1.624	1.630	0.252	471652	470	S
1.125	1.624	1.630	0.252	471652A	470	A
1.125	1.624	1.630	0.252	471652V	470	V
1.125	1.624	1.630	0.252	482208	480	S
1.125	1.630	1.634	0.313	710285	#	S
1.125	1.752	1.758	0.250	471692	470	S
1.125	1.752	1.758	0.250	471692A	470	A
1.125	1.752	1.758	0.313	450189	450	S
1.125	1.752	1.758	0.313	470189	470	S
1.125	1.752	1.758	0.313	470189H	470	H
1.125	1.780	1.785	0.250	204505	2040	S
1.125	1.781	1.790	0.409	323133	320	S
1.125	1.781	1.787	0.469	204020	2040	S
1.125	1.828	1.834	0.311	450045	450	S
1.125	1.828	1.832	0.312	476838	470	S
1.125	1.828	1.832	0.437	470045	470	S
1.125	1.850	1.859	0.311	350974	350	S
1.125	1.874	1.880	0.250	450236	450	S
1.125	1.874	1.880	0.250	470712	470	S
1.125	1.874	1.880	0.250	470712A	470	A
1.125	1.874	1.880	0.250	470712V	470	V
1.125	1.874	1.880	0.311	470236	470	S
1.125	1.874	1.878	0.625	6704	10S	S
1.125	1.935	1.942	0.625	6832S	2040	S
1.125	1.937	1.942	0.562	203003	2030	S
1.125	1.937	1.942	0.625	205004	2050	F
1.125	1.983	1.989	0.250	471747	470	S
1.125	1.983	1.987	0.375	472674	470	S
1.125	2.000	2.004	0.250	40160S	40S	S
1.125	2.000	2.006	0.252	471763	470	S
1.125	2.000	2.006	0.252	471763A	470	A
1.125	2.000	2.006	0.252	471763V	470	V
1.125	2.047	2.053	0.311	472644	470	S
1.125	2.047	2.053	0.311	472644V	470	V
1.125	2.062	2.066	0.250	471785	470	S
1.125	2.062	2.066	0.437	470241	470	S
1.125	2.063	2.069	0.313	450241	450	S
1.125	2.125	2.129	0.250	481792	480	S
1.125	2.250	2.254	0.500	450604	450	S

Shaft	Bore	O.D.	Width	Part Number	Style	Matl	Shaft	Bore	O.D.	Width	Part Number	Style	Matl	
1.125	2.250	2.254	0.500	470604	470	S	1.181	1.654	1.663	0.276	◆1970	350	S	
							30	42	42.24	7				
1.125	2.437	2.441	0.468	450332	450	S	1.181	1.654	1.663	0.276	◆223010→	320	S	
1.125	2.441	2.445	0.250	473259	470	S	30	42	42.24	7				
1.125	2.441	2.445	0.375	472681	470	S	1.181	1.654	1.661	0.276	◆304207XX	350	S	
1.125	2.441	2.445	0.375	472681V	470	V	30	42	42.20	7				
1.125	2.533	2.537	0.250	472535	470	S	1.181	1.732	1.743	0.276	◆304407XX	250	S	
							30	44	44.28	7				
1.125	2.835	2.841	0.374	472954	470	S	1.181	1.732	1.741	0.354	◆223012→	320	N	
1.125	2.835	2.841	0.374	472954V	470	V	30	44	44.22	9				
1.125	2.875	2.879	0.468	450430	450	S	1.181	1.772	1.780	0.197	◆304505XX	320	S	
							30	45	45.22	5				
1.126" 1 1/8"							1.181	1.772	1.781	0.236	◆223014	320	S	
1.126	1.693	1.699	0.256	1989	470	S	30	45	45.24	6				
1.142" 29mm							1.181	1.772	1.781	0.315	◆1981→	350	N	
1.142	1.772	1.781	0.315	◆320595←	320	S	30	45	45.24	8				
29	45	45.24	8				1.181	1.772	1.780	0.315	◆304508XX	320	S	
							30	45	45.20	8				
1.156" 1 5/32"							1.181	1.772	1.780	0.315	◆710359	#	S	
1.156	1.686	1.690	0.250	474260	470	S	30	45	45.20	8				
1.156	1.686	1.690	0.375	450502	450	S	1.181	1.772	1.780	0.591	◆2016	#	S	
1.156	1.752	1.756	0.312	471707	470	S	30	45	45.20	15				
1.156	1.752	1.756	0.312	471707N	470	N	1.181	1.811	1.820	0.276	◆223018→	320	S	
1.156	1.828	1.832	0.437	450482	450	S	30	46	46.23	7				
							1.181	1.811	1.819	0.276	◆304607XX	320	S	
1.156	1.874	1.878	0.250	471736	470	S	30	46	46.20	7				
1.156	1.984	1.988	0.250	473428	470	S	1.181	1.811	1.820	0.315	◆712001→	320	N	
1.156	2.000	2.006	0.311	450161	450	S	30	46	46.23	8				
1.156	2.062	2.068	0.374	473427	470	S	1.181	1.850	1.859	0.276	◆223020	350	S	
1.156	2.125	2.129	0.437	450362	450	S	30	47	47.22	7				
							1.181	1.850	1.860	0.276	◆304707XX	350	S	
1.156	2.125	2.129	0.437	470362	470	S	30	47	47.25	7				
1.156	2.834	2.839	0.375	472239	470	S	1.181	1.890	1.901	0.315	◆304808XX	350	S	
							30	48	48.28	8				
1.175"							1.181	1.890	1.899	0.315	◆714619	350	S	
1.175	1.771	1.775	0.275	483488→	480	S	30	48	48.24	8				
1.175	1.828	1.832	0.312	483054N	480	N	1.181	1.969	1.978	0.276	◆305007XX	350	S	
							30	50	50.23	7				
1.178"							1.181	1.969	1.976	0.315	◆305008XX	480	S	
1.178	2.447	2.452	0.500	4813V→	860	V	30	50	50.20	8				
							1.181	1.969	1.978	0.354	◆223050←	320	S	
1.181"							30	50	50.24	9				
1.181	1.457	1.461	0.138	710401	#	S	1.181	2.047	2.058	0.276	◆223035	350	S	
1.181	1.575	1.584	0.276	◆1129	350	S	30	52	52.27	7				
30	40	40.23	7				1.181	2.047	2.056	0.276	◆305207XX	350	S	
1.181	1.575	1.584	0.276	◆223005	480	S	30	52	52.23	7				
30	40	40.23	7				1.181	2.126	2.134	0.354	710267	320	S	
1.181	1.575	1.584	0.276	◆304007XX	350	S	1.181	2.165	2.176	0.394	◆305510XX	350	S	
30	40	40.23	7				30	55	55.28	10				
							1.181	2.205	2.213	0.315	◆305608XX	350	S	
							30	56	56.20	8				
1.181	2.283	2.287	0.374	◆3907	570	N	1.181	2.441	2.452	0.276	◆306207XX	350	S	
30	58	58.09	9.50				30	62	62.28	7				
1.181	2.835	2.845	0.394	◆307210XX	350	S	1.181	2.835	2.845	0.394	◆307210XX	350	S	
30	72	72.27	10				30	72	72.27	10				

Shaft	Bore	O.D.	Width	Part Number	Style	Matl
1.187"		1 3/16"				
1.187	1.627	1.635	0.250	340817	340	S
1.187	1.686	1.690	0.375	470328	470	S
1.187	1.716	1.720	0.248	9487	680	S
1.187	1.752	1.758	0.252	473203	470	S
1.187	1.828	1.832	0.375	473425	470	S
1.187	1.874	1.880	0.252	472475	470	S
1.187	1.983	1.987	0.375	473426	470	S
1.187	1.996	2.000	0.250	40576S	40S	S
1.187	2.000	2.004	0.250	40162S	40S	S
1.187	2.000	2.006	0.252	450162	450	S
1.187	2.000	2.006	0.252	470162	470	S
1.187	2.000	2.006	0.252	471765	470	S
1.187	2.047	2.051	0.250	43076S	40S	S
1.187	2.047	2.051	0.437	453063	450	S
1.187	2.062	2.068	0.250	471354	470	S
1.187	2.125	2.131	0.250	473205	470	S
1.187	2.165	2.169	0.250	472350	470	S
1.187	2.250	2.254	0.250	474255	470	S
1.187	2.250	2.254	0.500	470336	470	S
1.187	2.437	2.441	0.250	474254	470	S
1.187	2.437	2.441	0.468	470347	470	S
1.187	2.441	2.445	0.250	474256	470	S
1.187	2.686	2.690	0.500	470946	470	S
1.188"		1 3/16"				
1.188	2.440	2.446	0.251	472432	470	S
1.189"						
1.189	1.654	1.657	0.236	710340	440	V
1.190"						
1.190	1.687	1.693	0.252	481213	480	S
1.192"						
1.192	2.122	2.128	0.350	710068	#	S
1.218"						
1.218	1.968	1.972	0.468	203016	2030	S
1.218	1.979	1.983	0.250	441319	440	S
1.218	1.983	1.987	0.437	450048	450	S
1.218	2.000	2.004	0.437	450173	450	S
1.219"						
1.219	1.979	1.985	0.406	203025	2030	S

Shaft	Bore	O.D.	Width	Part Number	Style	Matl
1.220"						
1.220	1.654	1.661	0.315	710172	350	V
1.220	1.732	1.740	0.315	◆314408XX	320	S
31	44	44.20	8			
1.220	1.811	1.820	0.315	◆1121←	320	V
31	46	46.23	8			
1.220	1.811	1.820	0.315	◆710332←	320	N
31	46	46.23	8			
1.238"						
1.238	2.250	2.254	0.500	8293S	480	S
1.247"						
1.247	-	2.633	0.480	8429S	#	S
1.250"		1 1/4"				
1.250	1.250	1.838	0.187	240949	240	S
1.250	1.499	1.509	0.156	240736	240	S
1.250	1.500	1.509	0.125	343186	340	S
1.250	1.625	1.634	0.188	251511	250	S
1.250	1.685	1.694	0.188	340356	340	S
1.250	1.686	1.691	0.188	240356	240	S
1.250	1.686	1.692	0.219	353135	350	S
1.250	1.686	1.691	0.250	473135V	470	V
1.250	1.686	1.695	0.252	322353	320	S
1.250	1.687	1.696	0.313	323126	320	S
1.250	1.687	1.693	0.313	480356	480	S
1.250	1.688	1.694	0.252	474278	470	S
1.250	1.750	1.754	0.250	710014	#	U
1.250	1.751	1.757	0.251	470140N	470	N
1.250	1.752	1.756	0.250	40140S	40S	S
1.250	1.752	1.758	0.250	471413	470	S
1.250	1.752	1.758	0.250	471413A	470	A
1.250	1.752	1.758	0.250	471413V	470	V
1.250	1.752	1.758	0.252	451709	450	S
1.250	1.752	1.758	0.252	712025	470	S
1.250	1.752	1.758	0.252	7412S	480	S
1.250	1.752	1.758	0.313	471709	470	S
1.250	1.812	1.817	0.235	39713	TDW-H	T
1.250	1.874	1.880	0.252	471737	470	S
1.250	1.955	1.960	0.256	3199	480	S
1.250	1.955	1.960	0.256	3199S	480	S
1.250	1.968	1.972	0.468	6906S	2040	S
1.250	1.969	1.975	0.469	203012	2030	S
1.250	1.979	1.985	0.252	204507	2040	S
1.250	1.979	1.985	0.406	203029	2030	S
1.250	1.979	1.983	0.406	204029	2040	S

Shaft	Bore	O.D.	Width	Part Number	Style	Matl	Shaft	Bore	O.D.	Width	Part Number	Style	Matl
1.250	1.983	1.989	0.251	7781S	2030	S	1.260	1.654	1.661	0.394	◆223215←	320	S
1.250	1.983	1.989	0.252	450049	450	S	32	42	42.20	10			
1.250	1.983	1.989	0.252	470049	470	S							
1.250	1.983	1.989	0.252	471750	470	S							
1.250	1.983	1.989	0.252	471750A	470	A	1.260	1.693	1.701	0.276	◆324307XX	320	S
1.250	1.983	1.989	0.252	471750V	470	V	32	43	43.20	7			
1.250	2.000	2.011	0.250	40652S	40S	S	1.260	1.693	1.702	0.276	◆710370	320	S
1.250	2.000	2.006	0.252	450163	450	S	32	43	43.23	7			
1.250	2.000	2.006	0.252	471766	470	S	1.260	1.732	1.741	0.236	◆223220→	320	N
							32	44	44.22	6			
1.250	2.000	2.006	0.252	471766A	470	A	1.260	1.772	1.780	0.236	320348	320	V
1.250	2.000	2.006	0.252	471766V	470	V	1.260	1.772	1.781	0.276	◆223230	320	S
1.250	2.000	2.004	0.290	200338	2000	S	32	45	45.24	7			
1.250	2.000	2.006	0.437	470163	470	S	1.260	1.772	1.781	0.276	◆324507XX	320	S
1.250	2.000	2.006	0.438	410163	410	S	32	45	45.23	7			
1.250	2.047	2.058	0.297	473551	470	S	1.260	1.811	1.820	0.236	◆223235→	320	N
1.250	2.062	2.066	0.250	41787S	40S	S	32	46	46.23	6			
1.250	2.062	2.066	0.250	471787	470	S	1.260	1.811	1.820	0.236	◆324606XX	320	S
1.250	2.062	2.066	0.250	471787A	470	A	32	46	46.23	6			
1.250	2.062	2.066	0.437	450244	450	S	1.260	1.850	1.859	0.236	◆710310→	320	N
							32	47	47.22	6			
1.250	2.062	2.066	0.437	470244	470	S	1.260	1.850	1.859	0.276	◆324707XX	350	S
1.250	2.106	2.110	0.468	450177	450	S	32	47	47.23	7			
1.250	2.125	2.131	0.250	470245	470	S	1.260	1.850	1.859	0.315	◆3476→	320	N
1.250	2.125	2.131	0.250	471795	470	S	32	47	47.22	8			
1.250	2.125	2.131	0.250	471795N	470	N	1.260	1.890	1.899	0.276	◆223240→	400	N
							32	48	48.24	7			
1.250	2.125	2.131	0.251	482230N	480	N	1.260	1.890	1.899	0.276	◆710327→	320	S
1.250	2.250	2.256	0.250	42081S	40S	S	32	48	48.24	7			
1.250	2.250	2.254	0.435	7686S	250	S	1.260	1.890	1.898	0.315	◆324808XX	350	S
1.250	2.250	2.254	0.500	470165	470	S	32	48	48.20	8			
1.250	2.252	2.256	0.375	471801	470	S							
1.250	2.374	2.380	0.311	471808	470	S	1.260	1.890	1.899	0.394	◆710317←	320	S
1.250	2.402	2.408	0.228	710101↔	#	S	32	48	48.24	10			
1.250	2.437	2.443	0.311	471818	470	S	1.260	1.969	1.978	0.315	◆223250→	320	S
1.250	2.441	2.445	0.375	471407	470	S	32	50	50.24	8			
1.250	2.502	2.506	0.375	471833	470	S	1.260	1.969	1.978	0.315	◆325008XX	350	S
							32	50	50.23	8			
1.250	2.561	2.565	0.500	451845	450	S	1.260	1.969	1.974	0.315	◆710162	480	V
1.250	2.561	2.565	0.500	471845N	470	N	32	50	50.14	8			
1.250	2.686	2.690	0.375	481859	480	S	1.260	1.969	1.974	0.315	◆710164	480	V
1.250	2.713	2.717	0.468	450341	450	S	32	50	50.14	8			
1.250	2.835	2.841	0.374	470806	470	S	1.260	1.969	1.978	0.315	◆710415→	320	S
							32	50	50.24	8			
1.250	2.877	2.881	0.250	472536	470	S	1.260	2.047	2.058	0.276	◆223255	350	S
1.250	3.150	3.155	0.375	472651V	470	V	32	52	52.27	7			
1.250	3.155	3.160	0.500	453279	450	S	1.260	2.047	2.058	0.276	◆325207XX	350	S
							32	52	52.28	7			
							1.260	2.047	2.055	0.394	710306	320	S
							1.260	2.047	2.058	0.433	◆1167	320	N
							32	52	52.27	11			
							1.260	2.047	2.058	0.433	◆1167S	320	N
							32	52	52.27	11			
							1.260	2.047	2.058	0.433	◆223252←	320	N
							32	52	52.28	11			
							1.260	2.087	2.098	0.276	◆223253→	320	N
							32	53	53.29	7			
							1.260	2.126	2.132	0.354	◆2008	#	S
							32	54	54.15	9			

1.260"

32mm

Shaft	Bore	O.D.	Width	Part Number	Style	Matl
1.260 32	2.126 54	2.132 54.15	0.354 9	◆2008S	#	S
1.260 32	2.126 54	2.135 54.23	0.394 10	◆325410XX	320	S
1.260 32	2.205 56	2.216 56.28	0.394 10	◆325610XX	350	S
1.260 32	2.283 58	2.291 58.20	0.315 8	◆325808XX	320	S
1.260 32	2.362 60	2.370 60.20	0.315 8	◆326008XX	320	S
1.260 32	2.362 60	2.370 60.20	0.394 10	◆326010XX	480	S

1.260 32	2.441 62	2.449 62.20	0.315 8	◆326208XX	320	S
1.260 32	2.835 72	2.843 72.20	0.315 8	◆327208XX	320	S

1.281" 1 9/32"

1.281	1.752	1.756	0.375	51032S	50S	S
1.281	1.983	1.987	0.437	470050	470	S
1.281	2.000	2.006	0.250	353137	350	S
1.281	2.000	2.011	0.374	473424	470	S

1.299" 33mm

1.299 33	1.732 44	1.738 44.15	0.315 8	◆710070	470	S
1.299	1.779	1.784	0.256	39879	TFW-H	T
1.299	1.828	1.832	0.375	6370N	330	N
1.299 33	1.850 47	1.859 47.22	0.276 7	◆223340→	320	S
1.299 33	1.929 49	1.938 49.23	0.315 8	◆710236→	320	N

1.299 33	1.969 50	1.978 50.24	0.276 7	◆710328	350	S
1.299 33	1.969 50	1.978 50.25	0.472 12	◆1168←	320	S
1.299 33	1.969 50	1.978 50.25	0.472 12	◆335012XX	320	S
1.299	2.044	2.050	0.490	3348	470	S
1.299 33	2.047 52	2.057 52.25	0.236 6	◆335206XX	320	S

1.299 33	2.205 56	2.216 56.29	0.512 13	◆710132	400	N
1.299 33	2.323 59	2.334 59.28	0.433 11	◆710124	400	N
1.299	3.539	3.528	1.575	5210	350	N

1.301"

1.301	2.000	2.004	0.437	471193	470	S
1.301	2.620	2.625	0.315	710043	#	S

1.312" 1 5/16"

1.312	-	-	0.350	327878	320	S
1.312	1.752	1.760	0.187	240716	240	S

Shaft	Bore	O.D.	Width	Part Number	Style	Matl
1.312	1.828	1.833	0.250	39904	TFF	T
1.312	1.874	1.878	0.375	473423	470	S
1.312	1.983	1.987	0.375	473422	470	S

1.312	2.062	2.066	0.312	472826	470	S
1.312	2.062	2.066	0.437	470129	470	S
1.312	2.106	2.110	0.375	473421	470	S
1.312	2.166	2.172	0.375	473812	470	S
1.313	2.250	2.256	0.311	473212A	470	A

1.312	2.437	2.441	0.468	470503	470	S
1.312	2.502	2.506	0.375	481834	480	S
1.312	2.996	3.001	0.500	450147	450	S

1.313" 1 5/16"

1.313	1.625	-	0.156	722108	VS1	N
1.313	2.000	2.006	0.313	473210	470	S
1.313	2.125	2.131	0.311	473211	470	S
1.313	2.250	2.256	0.311	473212	470	S
1.313	2.282	2.286	0.250	40769S	40S	S

1.313	2.374	2.380	0.313	473213	470	S
1.313	2.835	2.841	0.375	471904	470	S

1.318"

1.318	2.280	2.285	0.354	5131	#	S
1.318	2.620	2.625	1.000	2300	#	S

1.322"

1.322	2.227	2.231	0.375	484058	480	S
-------	-------	-------	-------	--------	-----	---

1.326"

1.326	2.061	2.065	0.375	484054	480	S
-------	-------	-------	-------	--------	-----	---

1.328"

1.328	2.227	2.233	0.313	5124	480	S
-------	-------	-------	-------	------	-----	---

1.339" 34mm

1.339 34	1.732 44	1.741 44.23	0.315 8	◆223400	320	N
1.339 34	1.772 45	1.780 45.20	0.315 8	◆344508XX	320	S
1.339 34	1.890 48	1.899 48.24	0.295 7.50	◆710416	350	S
1.339 34	1.890 48	1.899 48.24	0.315 8	◆223420→	320	N
1.339 34	2.047 52	2.058 52.28	0.315 8	◆345208XX	320	S

1.339 34	2.087 53	2.098 53.28	0.315 8	◆223440	320	N
1.339 34	2.087 53	2.098 53.29	0.315 8	◆710418	320	N

Shaft	Bore	O.D.	Width	Part Number	Style	Matl	Shaft	Bore	O.D.	Width	Part Number	Style	Matl	
1.339	2.126	2.134	0.354	◆345409XX	350	S	1.375	-		0.375	50480S	450	S	
34	54	54.20	9				1.375	1.750	1.756	0.187	340853	340	S	
1.339	2.126	2.137	0.354	◆710110↔	400	N	1.375	1.828	1.834	0.250	323138	320	S	
34	54	54.28	9											
1.339	2.165	2.173	0.354	◆345509XX	320	S								
34	55	55.20	9				1.375	1.829	1.837	0.187	6597S	340	S	
							1.375	1.874	1.879	0.250	40395	40S	S	
1.339	2.441	2.448	0.394	◆346210XX	350	S	1.375	1.874	1.879	0.250	40395S	40S	S	
34	62	62.18	10				1.375	1.874	1.879	0.250	484156V	480	V	
1.339	2.441	2.452	0.394	◆710422	350	S	1.375	1.874	1.880	0.311	330663	330	S	
34	62	62.28	10											
1.339	2.480	2.491	0.354	◆710109↔	400	N	1.375	1.874	1.880	0.313	472354	470	S	
34	63	63.27	9				1.375	1.875	1.878	0.187	6668S	330	S	
1.339	2.559	2.563	0.472	◆710151	470	S	1.375	1.875	1.884	0.250	352354	350	S	
34	65	65.10	12				1.375	1.937	1.954	0.235	1987	330	N	
							1.375	1.937	1.954	0.235	1987S	330	N	
1.343"							1 11/32"							
1.343	2.106	2.110	0.375	473435	470	S	1.375	1.947	1.953	0.500	1097	330	S	
1.343	2.125	2.129	0.375	473436	470	S	1.375	1.947	1.953	0.500	1097N	330	S	
1.343	2.374	2.378	0.500	450054	450	S	1.375	1.952	1.953	0.500	2443	250	N	
1.343	2.441	2.445	0.375	483793	480	S	1.375	1.981	1.989	0.252	714655	480	N	
							1.375	2.000	2.004	0.250	40522S	40S	S	
1.350"														
1.350	1.620	1.625	0.355	710076	#	S	1.375	2.000	2.006	0.311	471268	470	S	
1.350	2.571	2.577	0.539	8594S	620	S	1.375	2.000	2.006	0.311	471268N	470	N	
							1.375	2.000	2.006	0.311	472258	470	S	
							1.375	2.000	2.006	0.311	472258A	470	A	
							1.375	2.000	2.006	0.311	472258V	470	V	
1.362"														
1.362	2.191	2.197	0.252	8133S	480	S	1.375	2.000	2.006	0.311	480570	480	S	
							1.375	2.000	2.006	0.311	5872S	450	S	
1.365"														
1.365	1.955	1.961	0.438	3214↔	480	S	1.375	2.000	2.004	0.312	482258V	480	V	
1.365	2.081	2.087	0.435	51322	50S	S	1.375	2.047	2.053	0.311	472642	470	S	
1.365	2.260	2.266	0.313	9569S	990	S	1.375	2.047	2.053	0.311	472642V	470	V	
1.365	2.374	2.380	0.435	9568	480	S								
1.370"														
1.370	1.375	2.438	0.250	715101	#	S	1.375	2.047	2.052	0.330	4529N→	680	N	
							1.375	2.062	2.073	0.375	450403	450	S	
1.372"														
1.372	2.250	2.515	1.197	7715S	#	S	1.375	2.062	2.073	0.375	470774	470	S	
1.372	4.560	4.567	0.480	8549S	#	S	1.375	2.062	2.073	0.375	470774V	470	V	
							1.375	2.062	2.073	0.375	6760S	350	S	
1.374"														
1.374	1.874	1.880	0.251	50395S	50S	S	1.375	2.062	2.068	0.438	470403	470	S	
1.374	1.983	1.989	0.311	482163	480	S	1.375	2.106	2.110	0.312	◆472287	470	S	
1.374	1.983	1.989	0.311	482163N	480	N	1.375	1.375	2.125	2.131	0.311			
1.374	2.244	2.250	0.374	2655←	790	N	1.375	2.125	2.131	0.311	470135	470	S	
							1.375	2.125	2.131	0.311	471192	470	S	
1.375"														
1.375	-	4.582	0.259	8676S	540	S	1.375	2.125	2.131	0.311	482576N	480	N	
1.375	-	4.582	0.259	9344S	540	S								
							1.375	2.125	2.129	0.375	39140	940	T	
							1.375	2.125	2.131	0.438	450135	450	S	
							1.375	2.250	2.254	0.250	40169S	40S	S	
							1.375	2.250	2.256	0.311	473214	470	S	
							1.375	2.250	2.256	0.311	473214A	470	A	
							1.375	2.250	2.256	0.500	470169	470	S	
							1.375	2.250	2.252	1.062	6200	90S	S	
							1.375	2.282	2.286	0.250	42763	40S	S	
							1.375	2.282	2.286	0.500	50402	50S	S	
							1.375	2.327	2.332	0.406	204027	2040	S	
							1.375	2.374	2.378	0.250	43089S	40S	S	

Shaft	Bore	O.D.	Width	Part Number	Style	Matl	Shaft	Bore	O.D.	Width	Part Number	Style	Matl
1.375	2.374	2.380	0.311	473215	470	S	1.378	1.890	1.899	0.394	◆1108→	320	V
1.375	2.374	2.378	0.500	3116←	710	N	35	48	48.24	10			
1.375	2.374	2.378	0.500	3116N←	710	N							
1.375	2.374	2.378	0.500	470055N	470	N							
1.375	2.374	2.380	0.500	480055	480	S	1.378	1.890	1.895	0.512	◆1215←	#	N
1.375	2.437	2.441	0.375	470950	470	S	35	48	48.13	13			
1.375	2.441	2.447	0.375	471276	470	S	1.378	1.890	1.895	0.512	◆1215N←	#	N
1.375	2.441	2.447	0.375	471276V	470	V	35	48	48.13	13			
1.375	2.500	2.506	0.313	471835	470	S	1.378	1.929	1.941	0.315	◆710178	#	S
							35	49	49.30	8			
1.375	2.500	2.506	0.313	7687S	470	S	1.378	1.949	1.962	0.394	◆1940→	320	N
1.375	2.502	2.506	0.250	7245	40S	S	35	49.50	49.83	10			
1.375	2.561	2.567	0.374	471847N	470	N							
1.375	2.561	2.567	0.374	473258	470	S	1.378	1.969	1.980	0.276	◆1980→	320	H
1.375	2.623	2.627	0.375	472843	470	S	35	50	50.29	7			
1.375	2.686	2.690	0.500	450776	450	S	1.378	1.969	1.976	0.276	◆355007XX	350	S
1.375	2.716	2.720	0.468	450456	450	S	35	50	50.20	7			
1.375	2.717	2.723	0.375	323125	320	S	1.378	1.969	1.980	0.276	◆3771→	350	H
1.375	2.750	2.754	0.500	450463	450	S	35	50	50.29	7			
1.375	2.835	2.841	0.311	473197	470	S	1.378	1.969	1.980	0.315	◆223520	350	S
							35	50	50.29	8			
1.375	2.835	2.841	0.311	473197V	470	V	1.378	1.969	1.978	0.315	◆355008XX	350	S
1.375	2.835	2.841	0.374	472658	470	S	35	50	50.24	8			
1.375	2.835	2.841	0.469	450452	450	S	1.378	1.969	1.982	0.315	◆713771→	350	V
1.375	2.875	2.879	0.468	471105	470	S	35	50	50.34	8			
1.375	3.000	3.006	0.500	470989	470	S	1.378	1.969	1.978	0.433	◆710324←	320	S
							35	50	50.24	11			
1.375	3.125	3.130	0.500	450516	450	S	1.378	1.969	1.980	0.453	◆710111←	#	N
1.375	3.149	3.155	0.374	471379	470	S	35	50	50.29	11.50			
1.375	3.350	3.357	0.469	450492	450	S	1.378	2.047	2.053	0.276	◆223535	330	S
1.375	3.542	3.549	0.397	4532N	930	N	35	52	52.15	7			
1.377"							1.378	2.047	2.055	0.276	◆355207XX	350	S
1.377	2.162	2.167	0.744	4614N↔	570	N	35	52	52.20	7			
1.377	2.874	2.881	0.693	4613N↔	570	N	1.378	2.047	2.052	0.315	◆355208XX	330	S
							35	52	52.13	8			
1.378"							1.378	2.047	2.058	0.315	◆3655→	320	N
1.378	1.732	1.738	0.276	◆710383	470	S	35	52	52.27	8			
35	44	44.15	7				1.378	2.047	2.058	0.315	◆3655S→	320	N
1.378	1.772	1.778	0.276	◆354507XX	350	S	35	52	52.27	8			
35	45	45.15	7				1.378	2.047	2.052	0.315	◆4052R↔	#	N
1.378	1.850	1.866	0.276	◆1172→	320	H	35	52	52.13	8			
35	47	47.40	7				1.378	2.047	2.061	0.315	◆713655	320	N
1.378	1.850	1.866	0.276	◆1172S→	320	H	35	52	52.35	8			
35	47	47.40	7				1.378	2.047	2.057	0.394	◆1170	320	S
1.378	1.850	1.859	0.276	◆223510	350	S	35	52	52.25	10			
35	47	47.22	7				1.378	2.047	2.057	0.394	◆1170S	320	S
							35	52	52.25	10			
1.378	1.850	1.859	0.276	◆354707XX	350	S	1.378	2.097	2.105	0.305	4040R←	#	N
35	47	47.23	7				1.378	2.126	2.134	0.315	◆355408XX	350	S
1.378	1.890	1.898	0.299	320249	320	V	35	54	54.20	8			
1.378	1.890	1.898	0.315	◆354808XX	320	S	1.378	2.126	2.132	0.315	◆710217	#	S
35	48	48.20	8				35	54	54.15	8			
1.378	1.890	1.899	0.315	◆714436	320	S	1.378	2.126	2.134	0.315	◆710331←	320	V
35	48	48.24	8				35	54	54.20	8			
							1.378	2.126	2.132	0.354	◆710199↔	#	N
							35	54	54.15	9			
							1.378	2.162	2.167	0.575	3543	570	H

Shaft	Bore	O.D.	Width	Part Number	Style	Matl	Shaft	Bore	O.D.	Width	Part Number	Style	Matl
1.378 35	2.165 55	2.176 55.27	0.315 8	◆223540	320	N	1.378 35	2.520 64	2.525 64.13	0.315 8	◆356408XX	470	N
1.378 35	2.165 55	2.176 55.27	0.315 8	◆223542	320	N	1.378 35	2.559 65	2.567 65.20	0.315 8	◆356508XX	320	S
1.378 35	2.165 55	2.174 55.10	0.315 8	◆355508XX	470	S	1.378 35	2.559 65	2.567 65.20	0.394 10	◆356510XX	320	S
1.378 35	2.165 55	2.172 55.17	0.315 8	◆473823	470	S	1.378 35	2.559 65	2.570 65.28	0.472 12	◆710335	320	S
1.378 35	2.165 55	2.174 55.23	0.433 11	◆355511XX	320	S	1.378 35	2.638 67	2.648 67.27	0.472 12	◆1173	320	N
1.378 35	2.205 56	2.216 56.29	0.315 8	◆2007→	#	S	1.378 35	2.677 68	2.688 68.28	0.354 9	◆1140→	320	N
1.378 35	2.205 56	2.216 56.29	0.315 8	◆2007N→	#	S	1.378 35	2.677 68	2.683 68.16	0.354 9	◆223580→	400	S
1.378 35	2.205 56	2.216 56.29	0.315 8	◆2007S→	#	S	1.378 35	2.677 68	2.685 68.20	0.354 9	◆710336←	400	N
1.378 35	2.205 56	2.213 56.20	0.315 8	◆355608XX	350	S	1.378 35	2.756 70	2.764 70.20	0.315 8	◆357008XX	320	S
1.378 35	2.205 56	2.216 56.29	0.315 8	◆710314←	400	N	1.378 35	2.835 72	2.846 72.28	0.394 10	◆357210XX	350	S
1.378 35	2.205 56	2.216 56.29	0.315 8	◆710315→	400	S	1.378 35	2.835 72	2.846 72.29	0.394 10	◆710360	350	S
1.378 35	2.205 56	2.213 56.20	0.354 9	◆710396↔	400	S	1.378 35	2.992 76	3.003 76.28	0.354 9	◆1136←	300	N
1.378 35	2.205 56	2.216 56.29	0.394 10	◆223543	320	S	1.378 35	2.992 76	3.003 76.28	0.354 9	◆1136S←	300	N
1.378 35	2.205 56	2.215 56.27	0.394 10	◆355610XX	320	S	1.378 35	2.992 76	3.003 76.28	0.354 9	◆1147→	320	N
1.378 35	2.205 56	2.216 56.29	0.394 10	◆710218	#	V	1.378 35	3.150 80	3.150 80.20	0.315 8	◆358008XX	320	S
1.378 35	2.240 56	2.247 56.29	2.540	710096	740	N	1.380"						
1.378 35	2.244 58	2.246 58.27	0.601 10	100165	#	S	1.380	2.288	2.291	0.750	710429	870	V
1.378 35	2.283 58	2.294 58.28	0.394 10	◆223550	450	S	1.391"						
1.378 35	2.283 58	2.294 58.28	0.394 10	◆355810XX	350	S	1.391	2.482	2.488	0.344	4795V↔	740	V
1.378 35	2.362 60	2.373 60.27	0.315 8	◆710424	350	S	1.399"						
1.378 35	2.362 60	2.371 60.23	0.394 10	◆356010XX	350	S	1.399	2.250	2.254	0.250	470672	470	S
1.378 35	2.362 60	2.368 60.15	0.472 12	◆710201	470	S	1.399	2.292	2.298	0.500	710166↔	740	S
1.378 35	2.441 62	2.452 62.28	0.276 7	◆223552	320	S	1.399	2.292	2.298	0.500	8660S↔	480	S
1.378 35	2.441 62	2.452 62.28	0.276 7	◆356207XX	350	S	1.400"						
1.378 35	2.441 62	2.452 62.28	0.354 9	◆223553→	400	N	1.400	1.969	2.000	0.250	1110	#	F
1.378 35	2.441 62	2.452 62.28	0.354 9	◆4901	400	N	1.400	2.282	2.293	0.394	4857↔	860	V
1.378 35	2.441 62	2.449 62.20	0.394 10	◆356210XX	350	S	1.400	2.478	2.486	0.521	710066	830	S
1.378 35	2.480 63	2.488 63.17	0.354 10	710138	400	S	1.406" 1 13/32"						
1.378 35	2.480 63	2.487 63.17	0.394 10	◆223554	#	S	1.406	2.125	2.129	0.437	50126	50S	S
1.378 35	2.480 64	2.491 64.13	0.394 8	710419	#	S	1.417" 36mm						
1.378 35	2.520 64	2.525 64.13	0.315 8	◆223555	470	N	1.417	1.732 36	1.741 44	0.197 5	◆710252	320	S

Shaft	Bore	O.D.	Width	Part Number	Style	Matl
1.417 36	1.811 46	1.817 46.15	0.354 9	◆710343	330	S
1.417 36	1.850 47	1.859 47.22	0.276 7	◆223601	350	S
1.417 36	1.850 47	1.858 47.20	0.276 7	◆364707XX	350	S
1.417 36	1.929 49	1.938 49.23	0.276 7	◆223602→	320	N
<hr/>						
1.417 36	1.969 50	1.974 50.14	0.276 7	◆223605	470	S
1.417 36	1.969 50	1.972 50.08	0.276 7	◆365007XX	470	S
1.417 36	1.969 50	1.980 50.29	0.315 8	◆710341←	320	S
1.417 36	2.047 52	2.055 52.20	0.276 7	◆365207XX	350	S
1.417 36	2.047 52	2.055 52.20	0.394 10	◆223608←	320	S
<hr/>						
1.417 36	2.126 54	2.137 54.28	0.276 7.50	710197	400	N
1.417 36	2.126 54	2.137 54.20	0.295 8	◆223610	350	S
1.417 36	2.126 54	2.134 54.20	0.315 8	◆365408XX	350	S
1.417 36	2.165 55	2.169 55.09	0.256 6.50	◆2003	470	S
1.417 36	2.165 55	2.169 55.09	0.256 6.50	◆2003N	470	S
<hr/>						
1.417 36	2.205 56	2.215 56.25	0.394 10	◆365610XX	350	S
1.417 36	2.250 58	2.254 58.25	0.250 8	474127	470	S
1.417 36	2.283 58	2.293 58.23	0.315 12	◆365808XX	470	S
1.417 36	2.283 58	2.293 58.23	0.472 12	◆365812XX	350	S
1.417 36	2.362 60	2.370 60.20	0.276 7	◆366007XX	320	S
<hr/>						
1.417 36	2.362 60	2.370 60.20	0.315 8	◆1965	480	V
1.417 36	2.441 62	2.452 62.28	0.276 7	◆366207XX	320	S
1.417 36	2.520 64	2.526 64.16	0.433 11	◆710152	#	S
1.417 36	2.559 65	2.567 65.20	0.315 8	◆710057	480	S
1.417 36	2.614 68	2.629 68.28	0.500 10	9342S	480	S
<hr/>						
1.417 36	2.677 68	2.688 68.28	0.394 10	◆366810XX	350	S
<hr/>						
1.436"						
1.436	2.062	2.073	0.250	352444	350	S
<hr/>						
1.437" 1 7/16"						
1.437	2.062	2.068	0.311	3395↔	470	S
1.437	2.125	2.131	0.313	473224	470	S
1.437	2.250	2.256	0.311	473016	470	S
1.437	2.312	2.318	0.374	472655	470	S

Shaft	Bore	O.D.	Width	Part Number	Style	Matl
1.437	2.374	2.380	0.311	470062	470	S
<hr/>						
1.437	2.374	2.380	0.311	473225	470	S
1.437	2.437	2.441	0.312	474264	470	S
1.437	2.441	2.451	0.374	◆4989	#	S
1.437	37 62	62.26	9.50			
1.437	2.441	2.445	0.375	481826	480	S
1.437	2.502	2.508	0.311	473226	470	S
<hr/>						
1.437	2.623	2.627	0.375	473437	470	S
1.437	2.750	2.754	0.500	470808	470	S
1.437	3.000	3.005	0.500	471405	470	S
<hr/>						
1.438"						
1.438	2.000	2.011	0.125	340930	340	S
<hr/>						
1.457" 37mm						
1.457	37 50	1.980 50.29	0.236 6	◆223750→	320	N
1.457	37 50.50	1.988 50.70	0.236 6	◆710355→	320	N
1.457	37 52	2.047 52.15	0.236 6	◆710149	#	S
1.457	37 52	2.058 52.28	0.315 8	◆375208XX	350	S
1.457	37 56	2.205 56.29	0.354 9	◆710259↔	320	V
<hr/>						
1.457	37 58	2.283 58.10	0.394 10	◆710353→	660	S
1.457	37 62	2.441 62.23	0.394 10	◆710228	400	S
1.457	37 78	3.071 78.30	0.472 12	◆239134	#	S
<hr/>						
1.465"						
1.465	2.372	2.374	0.433	710426	#	S
<hr/>						
1.468"						
1.468	2.375	2.379	0.375	473438	470	S
1.468	2.437	2.441	0.375	473439	470	S
<hr/>						
1.473"						
1.473	1.971	1.979	0.562	7235S	320	S
<hr/>						
1.479"						
1.479	2.563	2.567	0.470	710304	#	S
<hr/>						
1.484"						
1.484	2.254	2.258	0.250	40468	40S	S
1.484	2.254	2.258	0.312	50468	50S	S

Shaft	Bore	O.D.	Width	Part Number	Style	Matl	Shaft	Bore	O.D.	Width	Part Number	Style	Matl
1.491"							1.496	2.283	2.288	0.315	223842	480	V
1.491	2.191	2.197	0.250	8597S	480	S	1.496	2.283	2.288	0.315	◆385808XX	470	S
1.496" 38mm							38	58	58.11	8			
1.496	1.969	1.978	0.236	◆223802→	320	N	1.496	2.283	2.294	0.394	◆710139	#	N
38	50	50.25	6				38	58	58.27	10			
1.496	1.969	1.978	0.276	◆385007XX	350	S	1.496	2.283	2.294	0.433	◆1175	320	S
38	50	50.25	7				38	58	58.27	11			
1.496	1.969	1.980	0.315	◆223800→	320	N	1.496	2.323	2.334	0.354	◆1038→	320	N
38	50	50.28	8				38	59	59.28	9			
1.496	1.969	1.980	0.315	◆223801	320	S	1.496	2.362	2.370	0.315	◆386008XX	320	S
38	50	50.29	8				38	60	60.20	8			
1.496	2.047	2.058	0.236	◆1196	470	S	1.496	2.362	2.373	0.394	◆223843	350	S
38	52	52.27	6				38	60	60.27	10			
1.496	2.047	2.053	0.236	◆3357	2830	S	1.496	2.362	2.376	0.394	◆386010XX	350	S
38	52	52.15	6				38	60	60.35	10			
1.496	2.047	2.053	0.248	◆710309	#	S	1.496	2.441	2.445	0.236	710224	490	S
38	52	52.15	6.30				38	62	62.28	7			
1.496	2.047	2.058	0.276	◆1174	320	S	1.496	2.441	2.450	0.512	710209	#	N
38	52	52.27	7				1.496	2.480	2.487	0.394	◆2009	#	N
1.496	2.047	2.058	0.276	◆1174S	320	S	38	63	63.17	10			
38	52	52.27	7				1.496	2.480	2.487	0.394	◆2009S	#	N
1.496	2.047	2.058	0.276	◆1966→	350	Y	38	63	63.17	10			
38	52	52.27	7				1.496	2.559	2.567	0.315	◆386508XX	320	S
1.496	2.047	2.055	0.276	◆385207XX	320	S	38	65	65.20	8			
38	52	52.20	7				1.496	2.559	2.567	0.315	710435	320	S
1.496	2.047	2.057	0.335	◆38X52085XX	320	S	38	65	65.27	12			
38	52	52.25	8.50				1.496	2.559	2.570	0.472	◆1176→	#	N
1.496	2.047	2.055	0.354	239128	#	S	38	65	65.27	12			
1.496	2.058	2.063	0.250	482415	480	S	1.496	2.559	2.570	0.472	◆1176S→	#	N
1.496	2.087	2.098	0.276	◆1120←	320	V	38	65	65.27	12			
38	53	53.29	7				1.496	2.677	2.685	0.315	◆386808XX	320	S
1.496	2.087	2.098	0.276	◆1120S←	320	V	38	68	68.20	8			
38	53	53.29	7				1.496	2.559	2.570	0.472	◆1176S→	#	N
1.496	2.087	2.094	0.315	◆385308XX	320	S	38	65	65.27	12			
38	53	53.20	8				1.496	2.677	2.685	0.315	◆386808XX	320	S
1.496	2.126	2.133	0.276	◆385407XX	480	S	38	68	68.20	8			
38	54	54.18	7				1.496	2.677	2.685	0.394	◆386810XX	320	S
1.496	2.126	2.137	0.315	◆239146←	480	S	38	70	70.20	10			
38	54	54.28	8				1.496	2.756	2.764	0.394	◆387010XX	350	S
1.496	2.126	2.133	0.394	◆385410XX	320	S	38	70	70.20	10			
38	54	54.18	10				1.496	2.835	2.843	0.394	◆387210XX	350	S
1.496	2.126	2.130	0.984	39875	#	T	38	72	72.20	10			
1.496	2.165	2.174	0.276	◆385507XX	350	N	38	74	74.20	8			
38	55	55.23	7				1.496	2.913	2.921	0.315	◆387408XX	320	S
1.496	2.165	2.176	0.354	◆223830	350	N	38	74	74.20	8			
38	55	55.27	9				1.496	2.913	2.920	0.433	◆1177	320	N
1.496	2.165	2.176	0.354	◆223831→	320	N	38	74	74.17	11			
38	55	55.27	9				1.496	2.913	2.921	0.433	◆387411XX	320	N
1.496	2.205	2.216	0.394	◆385610XX	350	S	38	74	74.20	11			
38	56	56.28	10				1.500" 1 1/2"						
1.496	2.244	1.850	0.276	◆223805	250	S	1.500	1.874	1.879	0.250	253099	250	S
38	57	47.00	7				1.500	1.874	1.880	0.250	343099	340	S
1.496	2.283	2.290	0.315	◆223840	470	S	1.500	1.875	-	0.188	710044	#	S
38	58	58.17	8				1.500	1.938	1.942	0.250	42260S	40S	S
1.496	2.283	2.288	0.315	◆223842	480	V	1.500	1.983	1.989	0.189	443018	440	S
38	58	58.11	8				1.500	1.983	1.987	0.250	40382	40S	S
1.496	2.283	2.288	0.315	◆385808XX	470	S	1.500	1.983	1.989	0.252	452554	450	S
38	58	58.11	8				1.500	1.983	1.989	0.252	452554N	450	N
1.496	2.283	2.294	0.394	◆710139	#	N	1.500	1.983	1.989	0.252	472554	470	S
38	58	58.27	10										

Shaft	Bore	O.D.	Width	Part Number	Style	Matl
1.500	1.983	1.989	0.252	474276	470	S
1.500	1.989	1.995	0.250	3677	2870	S
1.500	1.989	1.993	0.250	41257	40S	S
1.500	1.997	2.001	0.531	6759S	10S	S
1.500	2.000	2.010	0.187	240319	240	S
1.500	2.000	2.004	0.250	710023	#	U
1.500	2.000	2.011	0.252	352521	350	S
1.500	2.000	2.006	0.313	481163	480	S
1.500	2.048	2.052	0.375	472466	470	S
1.500	2.062	2.068	0.219	7537S	240	S
1.500	2.062	2.066	0.250	480630	480	S
1.500	2.062	2.066	0.250	6545	210	F
1.500	2.062	2.066	0.375	480991	480	S
1.500	2.062	2.068	0.438	470451	470	S
1.500	2.125	2.131	0.311	470394	470	S
1.500	2.125	2.131	0.311	473227	470	S
1.500	2.125	2.131	0.311	473227V	470	V
1.500	2.125	2.131	0.437	350394	350	S
1.500	2.187	2.187	0.500	6312	80S	S
1.500	2.192	2.196	0.250	43078S	40S	S
1.500	2.222	2.226	0.312	480844	480	S
1.500	2.250	2.258	0.250	340136	340	S
1.500	2.250	2.256	0.311	470548	470	S
1.500	2.250	2.256	0.311	470625	470	S
1.500	2.250	2.256	0.311	470625A	470	A
1.500	2.250	2.256	0.311	470625V	470	V
1.500	2.250	2.256	0.311	5115	470	S
1.500	2.250	2.260	0.312	322373	320	S
1.500	2.250	2.524	0.312	480625V	480	V
1.500	2.250	2.256	0.313	331228H→	750	N
1.500	2.250	2.256	0.313	453065	450	S
1.500	2.250	2.256	0.375	450548	450	S
1.500	2.250	2.254	0.375	710012	#	U
1.500	2.250	2.253	0.500	710020	#	U
1.500	2.256	-	.270	200859	2000	S
1.500	2.260	2.264	0.405	9363S	410	S
1.500	2.311	2.315	0.500	712023	#	V
1.500	2.327	2.333	0.406	203013	2030	S
1.500	2.327	2.333	0.406	204013	2040	S
1.500	2.328	2.332	0.437	472591	470	S
1.500	2.372	2.376	0.420	2194←	880	N
1.500	2.372	2.378	0.813	7692S←	790	S
1.500	2.374	2.380	0.311	410059	410	S
1.500	2.374	2.380	0.311	470380	470	S
1.500	2.374	2.380	0.311	470380A	470	A
1.500	2.374	2.380	0.311	470380V	470	V
1.500	2.374	-	0.313	10059S	470	S
1.500	2.374	2.380	0.313	450059	450	S
1.500	2.374	2.380	0.313	470059	470	S
1.500	2.377	2.629	0.311	472189A←	470	S

Shaft	Bore	O.D.	Width	Part Number	Style	Matl
1.500	2.377	2.388	0.433	710441	#	N
1.500	2.437	2.441	0.250	7886S	480	S
1.500	2.437	2.441	0.375	471820	470	S
1.500	2.438	2.444	0.250	40063S	40S	S
1.500	2.441	2.447	0.313	471344	470	S
1.500	2.462	2.482	0.290	200861	2000E	S
1.500	2.500	2.500	0.375	710414	#	T
1.500	2.502	2.508	0.311	473228	470	S
1.500	2.502	2.508	0.311	51098	480	S
1.500	2.502	2.508	0.375	481837	480	S
1.500	2.502	2.506	0.375	6426	40S	S
1.500	2.502	2.506	0.437	480067	480	S
1.500	2.502	2.508	0.500	450067	450	S
1.500	2.561	2.565	0.500	410190	410	S
1.500	2.561	2.565	0.500	470190	470	S
1.500	2.623	2.627	0.500	451857	450	S
1.500	2.686	2.690	0.500	470487	470	S
1.500	2.686	2.690	0.500	470487N	470	N
1.500	2.716	2.720	0.468	450984	450	S
1.500	2.750	2.754	0.312	473440	470	S
1.500	2.750	2.754	0.500	450461	450	S
1.500	2.758	2.763	0.312	474281	470	S
1.500	2.758	2.762	0.500	470077	470	S
1.500	2.835	2.839	0.468	471915	470	S
1.500	2.875	2.879	0.468	450523	450	S
1.500	2.996	3.001	0.500	450326	450	S
1.500	3.000	3.006	0.374	471958	470	S
1.500	3.149	3.155	0.438	472446	470	S
1.500	3.189	3.194	0.437	450540	450	S
1.500	3.543	3.550	0.375	455308	450	S
1.502" 1 1/2"						
1.502	2.126	2.132	0.492	4530←	960	N
1.502	2.377	2.381	0.500	4583←	860	N
1.502	2.378	2.384	0.469	9613S←	710	S
1.503" 1 1/2"						
1.503	2.374	2.379	0.374	4934	790	N
1.503	2.376	2.383	0.420	4370N←	880	N
1.504" 1 1/2"						
1.504	1.937	1.950	0.475	710247←	#	N
1.516"						
1.516	2.087	2.096	0.315	710233→	320	N
1.516	2.283	2.291	0.335	710318	320	N

Shaft	Bore	O.D.	Width	Part Number	Style	Matl
1.521"						
1.521	2.656	2.662	0.424	8611N	740	S
1.523"						
1.523	2.714	2.720	0.500	8940S	480	S
1.524"						
1.524	2.656	2.662	0.391	8610→	740	S
1.531" 1 17/32"						
1.531	2.374	2.378	0.375	452222	450	S
1.531	2.374	2.379	0.375	472222	470	S
1.535"						
1.535	1.969	1.980	0.433	710120	#	N
1.535	1.984	1.991	0.335	◆1126	250	S
39	50.40	50.57	8.50			
1.535	1.984	1.991	0.335	◆1126S	250	S
39	50.40	50.57	8.50			
1.535	2.000	2.008	0.295	1128S	350	S
1.535	2.047	2.053	0.248	◆1205	470	S
39	52	52.15	6.30			
1.535	2.047	2.053	0.248	◆1205N	470	S
39	52	52.15	6.30			
1.535	2.047	2.053	0.248	◆710338	660	S
39	52	52.15	6.30			
1.535	2.244	2.259	0.380	324204	320	V
1.535	2.244	2.255	0.433	◆710123	400	N
39	57	57.28	11			
1.535	2.244	2.255	0.610	◆710122	400	N
39	57	57.28	15.50			
1.535	2.323	2.334	0.433	710214	400	N
1.535	2.323	2.334	0.669	◆710118	400	S
39	59	59.28	17			
1.550"						
1.550	2.669	2.675	0.500	8695L	50S	S
1.550	2.669	2.675	0.500	8695S	470	S
1.552"						
1.552	2.447	2.452	0.500	710046→	860	S
1.552	2.502	2.506	0.500	472635	470	S
1.552	2.750	2.755	0.590	4244	720	S
1.552	3.160	3.165	0.608	4941V	#	V
1.552	3.160	3.167	0.608	5778	720	N
1.552	3.160	3.167	0.608	5778V	720	V

Shaft	Bore	O.D.	Width	Part Number	Style	Matl
1.558"						
1.558	2.250	2.254	1.520	8935S	790	S
1.562" 1 9/16"						
1.562	2.061	2.275	0.338	1195	320	S
1.562	2.062	2.067	0.188	39920	TFW-H	T
1.562	2.062	2.066	0.250	330749V	330	V
1.562	2.096	2.102	0.250	340927	340	S
1.562	2.125	2.129	0.375	39711	TFW-H	T
1.562	2.125	2.129	0.375	473517	470	S
1.562	2.237	2.257	0.290	200887	2000E	S
1.562	2.374	2.378	0.250	40438S	40S	S
1.563	2.374	2.380	0.311	472299V	470	V
1.562	2.441	2.445	0.375	471827	470	S
1.562	2.441	2.445	0.500	8160S	320	S
1.562	2.441	2.445	0.781	10684S	10S	S
1.562	2.502	2.506	0.250	40185	40S	S
1.562	2.502	2.506	0.312	711552	470	N
1.562	2.531	2.621	0.285	200640	2000E	S
1.562	2.531	2.621	0.285	200640S	200E	S
1.562	2.561	2.565	0.500	450143	450	S
1.562	2.684	2.701	0.250	6336S	260	S
1.562	2.686	2.690	0.375	5796	2010	S
1.562	2.716	2.720	0.468	450803	450	S
1.562	2.750	2.754	0.500	470109N	470	N
1.562	2.758	2.762	0.500	450273	450	S
1.562	3.150	3.155	0.312	473490	470	S
1.563" 1 9/16"						
1.563	2.062	2.068	0.203	7994S	440	S
1.563	2.063	2.069	0.250	8421S	330	S
1.563	2.250	2.256	0.311	472213	470	S
1.563	2.311	2.322	0.374	◆1873→	350	S
40	58.70	58.98	9.50			
1.563	2.372	2.378	0.335	2506←	790	S
1.563	2.374	2.380	0.311	472299	470	S
1.563	2.438	2.444	0.375	470064	470	S
1.563	2.438	2.444	0.375	471821	470	S
1.563	2.502	2.508	0.311	450185	450	S
1.563	2.502	2.508	0.311	473229	470	S
1.563	2.623	2.629	0.313	470682	470	S
1.563	2.686	2.692	0.313	471316	470	S
1.563	2.750	2.756	0.375	473441	470	S
1.565"						
1.565	2.372	2.383	0.394	710198	#	S

Shaft	Bore	O.D.	Width	Part Number	Style	Matl	Shaft	Bore	O.D.	Width	Part Number	Style	Matl
1.567" 40mm							1.575	2.165	2.176	0.315	◆405508XX	350	S
							40	55	55.28	8			
1.567	2.205	2.216	0.315	◆224025→	320	N	1.575	2.165	2.176	0.315	◆473677	470	S
40	56	56.29	8				40	55	55.27	8			
1.574" 40mm							1.575	2.185	2.191	0.354	◆710300	#	S
							40	55.50	55.65	9			
1.574	2.410	2.415	0.540	714569	#	V	1.575	2.205	2.213	0.276	◆405607XX	320	S
40							40	56	56.20	7			
1.574	2.676	2.683	0.500	4141	#	N	1.575	2.205	2.216	0.315	◆712551	320	S
40							40	56	56.29	8			
1.575" 40mm							1.575	2.205	2.216	0.354	◆224026↔	350	V
							40	56	56.29	9			
1.575	0.101	2.559	0.374	◆474161	470	S	1.575	2.244	2.252	0.394	◆405710XX	320	S
40	2.56	65.00	9.50				40	57	57.20	10			
1.575	1.969	1.976	0.315	◆405008XX	350	S	1.575	2.244	2.252	0.394	710432	320	S
40	50	50.20	8				40	58	58.20	8			
1.575	2.047	2.057	0.236	◆1178	320	S	1.575	2.283	2.291	0.315	◆405808XX	350	S
40	52	52.25	6				40	58	58.20	8			
1.575	2.047	2.057	0.236	◆1178S	320	S	1.575	2.283	2.290	0.354	◆3459↔	740	N
40	52	52.25	6				40	58	58.17	9			
1.575	2.047	2.058	0.236	◆224015→	320	S	1.575	2.283	2.290	0.354	◆3459S↔	740	N
40	52	52.27	6				40	58	58.17	9			
1.575	2.047	2.058	0.236	◆710308→	320	S	1.575	2.283	2.294	0.394	◆405810XX	320	S
40	52	52.27	6				40	58	58.28	10			
1.575	2.047	2.053	0.276	◆1217	350	N	1.575	2.362	2.368	0.315	◆710147	#	S
40	52	52.15	7				40	60	60.15	8			
1.575	2.047	2.053	0.276	◆1962	780	S	1.575	2.362	2.373	0.394	◆224040	350	S
40	52	52.15	7				40	60	60.27	10			
1.575	2.047	2.053	0.276	◆224010	350	S	40	60	60.20	10			
40	52	52.15	7				1.575	2.441	2.449	0.276	◆406207XX	350	S
1.575	2.047	2.058	0.276	◆224052→	320	H	40	62	62.20	7			
40	52	52.27	7				1.575	2.441	2.451	0.315	◆406208XX	320	S
							40	62	62.25	8			
1.575	2.047	2.057	0.276	◆405207XX	350	S	1.575	2.441	2.449	0.354	◆710131	#	S
40	52	52.25	7				40	62	62.20	9			
1.575	2.047	2.055	0.354	◆4175	#	S	1.575	2.441	2.452	0.394	710196	320	V
40	52	52.20	9				40	62	62.28	11			
1.575	2.047	2.058	0.591	◆239201	320	S	40	62	62.25	11.50			
40	52	52.27	15				1.575	2.441	2.451	0.315	◆406208XX	320	S
1.575	2.126	2.132	0.209	◆1213	470	S	40	62	62.25	11.50			
40	54	54.15	5.30				1.575	2.480	2.491	0.315	◆224063→	320	N
1.575	2.126	2.132	0.209	◆1213N	470	S	40	63	63.27	8			
40	54	54.15	5.30				1.575	2.520	2.526	0.472	◆1216	740	N
							40	64	64.16	12			
1.575	2.126	2.132	0.209	◆1213S	470	S	1.575	2.520	2.526	0.472	◆1216N	740	N
40	54	54.15	5.30				40	64	64.16	12			
1.575	2.126	2.134	0.217	◆405406XX	470	S	1.575	2.520	2.526	0.472	◆710326	660	S
40	54	54.20	5.50				40	64	64.16	12			
1.575	2.126	2.132	0.236	◆710311	250	S	1.575	2.559	2.565	0.394	◆224100	350	S
40	54	54.15	6				40	65	65.15	10			
1.575	2.126	2.137	0.236	◆710444←	320	S							
40	54	54.28	6				1.575	2.559	2.570	0.394	◆406510XX	350	S
1.575	2.126	2.134	0.394	710287	320	N	40	65	65.28	10			
40							1.575	2.598	2.609	0.315	◆224066→	400	N
							40	66	66.27	8			
1.575	2.161	2.165	0.512	710443	#	N	1.575	2.677	2.709	0.315	◆406808XX	350	S
40							40	68	68.80	8			
1.575	2.165	2.173	0.256	◆405506XX	350	S	1.575	2.677	2.681	0.354	224068	400	N
40	55	55.20	6.50				40	68	68.25	12			
1.575	2.165	2.176	0.315	◆224020→	320	S	1.575	2.677	2.687	0.472	◆406812XX	350	S
40	55	55.27	8				40	68	68.25	12			
1.575	2.165	2.172	0.315	◆3392	470	S							
40	55	55.17	8										

Shaft	Bore	O.D.	Width	Part Number	Style	Matl
1.575	2.756	2.764	0.315	◆407008XX	320	S
40	70	70.20	8			
1.575	2.835	2.844	0.276	◆350572	350	V
40	72	72.24	7			
1.575	2.835	2.848	0.276	◆407207XX	350	S
40	72	72.35	7			
1.575	2.874	2.878	0.492	◆710284	#	N
40	73	73.10	12.50			
1.575	2.913	2.918	0.394	◆474133	470	S
40	74	74.12	10			
1.575	2.953	2.959	0.472	◆2011→	400	N
40	75	75.16	12			
1.575	2.953	2.959	0.472	◆2011S→	400	N
40	75	75.16	12			
1.575	2.953	2.965	0.472	710113	#	S
1.575	2.953	2.961	0.472	◆712011	320	S
40	75	75.20	12			
1.575	2.953	2.964	0.472	◆712020←	320	N
40	75	75.29	12			
1.575	2.992	3.003	0.354	◆1036→	400	N
40	76	76.28	9			
1.575	2.992	3.003	0.354	◆1146←	320	N
40	76	76.28	9			
1.575	2.992	3.003	0.354	◆1146S←	320	N
40	76	76.28	9			
1.575	3.071	3.102	0.315	◆407808XX	320	S
40	78	78.80	8			
1.575	3.071	3.079	0.394	◆407810XX	350	S
40	78	78.20	10			
1.575	3.150	3.161	0.394	◆408010XX	350	S
40	80	80.28	10			
1.575	3.543	3.551	0.315	◆409008XX	350	S
40	90	90.20	8			
1.578"						
1.578	2.000	2.004	0.250	43074S	40S	S
1.593" 1 19/32"						
1.593	2.437	2.441	0.468	450065	450	S
1.593	2.502	2.506	0.250	482253	480	S
1.593	2.623	2.627	0.340	451469	450	S
1.593	2.758	2.762	0.500	450274	450	S
1.594"						
1.594	2.067	2.075	0.236	710436	350	N
1.594	2.125	2.129	0.250	480581	480	S
1.594	2.283	2.293	0.315	710140	320	S
1.598"						
1.598	2.476	2.483	0.420	4764←	860	N
1.605"						
1.605	2.374	2.386	0.375	1192	320	S

Shaft	Bore	O.D.	Width	Part Number	Style	Matl
1.605	2.795	2.804	0.364	4674N↔	#	N
1.610"						
1.610	2.500	2.531	0.300	6283S	260	S
1.614" 41mm						
1.614	2.087	2.093	0.276	◆1950	410	S
41	53	53.16	7			
1.614	2.126	2.135	0.276	224150	350	N
1.614	2.165	2.172	0.236	◆1180	320	S
41	55	55.17	6			
1.614	2.165	2.172	0.236	◆1180S	320	S
41	55	55.17	6			
1.614	2.165	2.177	0.276	◆415507XX	320	S
41	55	55.29	7			
1.614	2.205	2.211	0.276	◆1181	350	S
41	56	56.16	7			
1.614	2.205	2.215	0.276	◆415607XX	350	S
41	56	56.25	7			
1.614	2.323	2.334	0.394	◆710114→	980	N
41	59	59.28	10			
1.614	2.402	2.409	0.394	710141	#	N
1.614	2.435	2.441	0.300	2658	750	H
1.614	2.441	2.450	0.354	◆710220→	320	N
41	62	62.23	9			
1.614	2.480	2.488	0.354	◆710291←	400	N
41	63	63.20	9			
1.614	2.677	2.685	0.512	710402	#	S
1.618"						
1.618	2.000	2.004	0.235	484206	480	S
1.618	2.575	2.581	0.489	8835S↔	330	S
1.618	2.841	2.847	0.500	4762N↔	740	N
1.625" 1 5/8"						
1.625	2.000	2.004	0.250	473694	470	S
1.625	2.116	2.127	0.312	324939	320	S
1.625	2.116	2.120	0.312	472419	470	S
1.625	2.125	2.131	0.252	481181	480	S
1.625	2.125	2.131	0.252	481181N	480	N
1.625	2.250	2.256	0.311	1999	480	S
1.625	2.250	2.256	0.311	473230	470	S
1.625	2.250	2.254	0.312	483230V	480	V
1.625	2.282	2.286	0.313	710204	480	S
1.625	2.328	2.327	0.406	205017	2050	F
1.625	2.328	2.334	0.437	204017	2040	S
1.625	2.328	2.332	0.437	473117	470	S
1.625	2.374	2.380	0.311	450358	450	S
1.625	2.374	2.380	0.311	453341	450	S
1.625	2.374	2.380	0.311	470358	470	S
1.625	2.374	2.380	0.311	470358N	470	N

Shaft	Bore	O.D.	Width	Part Number	Style	Matl
1.625	2.374	2.380	0.311	473231	470	S
1.625	2.374	2.380	0.311	473231A	470	A
1.625	2.374	2.380	0.311	710358	450	N
1.625	2.374	2.380	0.311	710358N	480	S
<hr/>						
1.625	2.410	2.440	0.361	710102	#	S
1.625	2.415	2.440	0.500	4143	#	N
1.625	2.437	2.441	0.312	473367	470	S
1.625	2.437	2.441	0.312	483367V	480	V
1.625	2.438	2.444	0.375	450066	450	S
<hr/>						
1.625	2.438	2.444	0.375	470066	470	S
1.625	2.438	2.444	0.375	471419	470	S
1.625	2.438	2.444	0.375	471829	470	S
1.625	2.438	2.444	0.375	471829V	470	V
1.625	2.441	2.444	0.500	710063	#	N
<hr/>						
1.625	2.462	-	.250	200641	2000E	S
1.625	2.502	2.506	0.250	472758V	470	V
1.625	2.502	2.508	0.311	450194	450	S
1.625	2.502	2.508	0.311	473010	470	S
1.625	2.502	2.508	0.311	473010A	470	A
<hr/>						
1.625	2.502	2.508	0.311	473010N	470	N
1.625	2.562	2.568	0.252	204500	40S	S
1.625	2.562	2.566	0.375	291099	290	F
1.625	2.562	2.565	0.375	474216	470	S
1.625	2.562	2.566	0.437	4763S	#	S
<hr/>						
1.625	2.623	2.629	0.311	473232	470	S
1.625	2.623	2.629	0.313	450069	450	S
1.625	2.625	2.629	0.250	40568S	40S	S
1.625	2.625	2.629	0.500	50568	50S	T
1.625	2.625	2.629	0.500	50569	50S	T
<hr/>						
1.625	2.686	2.692	0.313	481864	480	S
1.625	2.722	2.727	0.406	5727	2050	F
1.625	2.750	2.754	0.250	40286	40S	S
1.625	2.750	2.754	0.312	474274	470	S
1.625	2.750	2.754	0.375	473443	470	S
<hr/>						
1.625	2.750	2.754	0.500	470286	470	S
1.625	2.758	2.762	0.500	450275	450	S
1.625	2.835	2.839	0.468	450819	450	S
1.625	2.875	2.881	0.313	450078	450	S
1.625	2.875	2.881	0.313	473444	470	S
<hr/>						
1.625	2.875	2.881	0.313	473444V	470	V
1.625	2.875	2.879	0.437	471923N	470	N
1.625	2.996	3.001	0.500	450415	450	S
1.625	2.999	3.005	0.313	450539	450	S
1.625	3.000	3.004	0.312	414268	410	S
<hr/>						
1.625	3.062	3.066	0.500	450335	450	S
1.625	3.251	3.256	0.500	450467	450	S
<hr/>						
1.627"						
<hr/>						
1.627	2.125	2.131	0.342	710202	680	S

Shaft	Bore	O.D.	Width	Part Number	Style	Matl
1.627	2.277	2.283	0.342	710241	680	S
<hr/>						
1.645"						
<hr/>						
1.645	2.656	2.660	0.406	8620N	470	N
<hr/>						
1.650"						
<hr/>						
1.650	2.205	2.216	0.276	710386→	320	H
1.650	2.282	2.336	0.768	3083	480	H
<hr/>						
1.654"						
<hr/>						
42mm						
<hr/>						
1.654	2.165	2.172	0.236	◆224200	320	S
42	55	55.17	6			
1.654	2.165	2.172	0.236	◆224200S	320	S
42	55	55.17	6			
1.654	2.165	2.172	0.236	◆224210	350	S
42	55	55.17	6			
1.654	2.165	2.173	0.276	◆425507XX	320	S
42	55	55.20	7			
1.654	2.165	2.178	0.315	◆224205→	320	N
42	55	55.33	8			
<hr/>						
1.654	2.165	2.176	0.315	◆3051→	330	H
42	55	55.27	8			
1.654	2.165	2.176	0.315	◆3051N→	330	H
42	55	55.27	8			
1.654	2.165	2.176	0.315	◆425508XX	350	S
42	55	55.28	8			
1.654	2.165	2.172	0.354	◆1214	470	S
42	55	55.17	9			
1.654	2.165	2.172	0.354	◆1214N	470	S
42	55	55.17	9			
<hr/>						
1.654	2.205	2.213	0.276	◆224220	490	S
42	56	56.21	7			
1.654	2.205	2.218	0.276	◆3774→	350	H
42	56	56.34	7			
1.654	2.205	2.218	0.276	◆3774S→	350	H
42	56	56.34	7			
1.654	2.205	2.210	0.276	◆425607XX	320	S
42	56	56.13	7			
1.654	2.205	2.216	0.276	◆710097	#	S
42	56	56.29	7			
<hr/>						
1.654	2.205	2.209	0.551	710221	#	N
1.654	2.213	2.224	0.236	◆494117	490	S
42	56.20	56.49	6			
1.654	2.216	2.222	0.315	710186	#	S
1.654	2.224	2.232	0.315	710244	#	S
1.654	2.283	2.287	0.276	◆425807XX	480	S
42	58	58.10	7			
<hr/>						
1.654	2.283	2.290	0.276	474241V→	470	V
1.654	2.283	2.290	0.354	◆224235	480	S
42	58	58.17	9			
1.654	2.283	2.294	0.374	◆224215←	320	N
42	58	58.27	9.50			
1.654	2.323	2.329	0.303	◆710442→	480	N
42	59	59.16	7.70			

Shaft	Bore	O.D.	Width	Part Number	Style	Matl	Shaft	Bore	O.D.	Width	Part Number	Style	Matl
1.654 42	2.362 60	2.373 60.27	0.276 7	◆1953	320	N	1.654	56.000	2.206	0.275	473560N→	470	N
1.656"													
1.654 42	2.362 60	2.373 60.27	0.276 7	◆1953S	320	N	1.656	2.502	2.506	0.500	450260	450	S
1.654 42	2.362 60	2.373 60.27	0.276 7	◆2025	320	V	1.656	2.623	2.627	0.455	7457N→	10S	N
1.654 42	2.362 60	2.371 60.22	0.276 7	◆426007XX	320	S	1.656	2.686	2.690	0.500	450073	450	S
1.654 42	2.441 62	2.452 62.28	0.276 7	◆224252	320	S	1.656	2.938	2.944	0.374	472660	470	S
1.654	2.441	2.449	0.276	710301	970	S	1.670"						
1.654 42	2.441 62	2.452 62.28	0.276 7	◆710408	320	N	1.670	2.686	2.690	0.500	452086	450	S
1.654 42	2.441 62	2.452 62.27	0.315 8	◆426208XX	350	S	1.673"						
1.654 42	2.441 62	2.452 62.28	0.394 10	◆224250→	350	S	1.673	2.162	2.168	0.285	4099	2870	S
1.654 42	2.441 62	2.445 62.10	0.472 12	◆710403	#	S	1.673	2.165 43	2.176 55	0.236 6	◆2012→	320	Y
1.654 42	2.480 63	2.491 63.27	0.354 9	◆710298→	400	N	1.675"						
1.654	2.518	2.525	0.394	3622	740	S	1.675	2.000	2.175	0.200	710385	#	S
1.654	2.518	2.525	0.394	3622S	740	S	1.685"						
1.654 42	2.524 64.10	2.535 64.39	0.236 6	◆224254	340	S	1.685	2.500	2.506	1.535	7300S	790	N
1.654	2.551	2.555	0.531	710179→	320	S	1.687" 1 11/16"						
1.654 42	2.559 65	2.565 65.15	0.394 10	◆224255	470	N	1.687	2.279	2.285	0.250	353141	350	S
1.654 42	2.559 65	2.565 65.15	0.394 10	◆426510XX	470	N	1.687	2.327	2.332	0.500	203008	2030	S
1.654	2.598	2.609	0.394	224266	320	S	1.687	2.374	2.380	0.311	473233	470	S
1.654	2.638	2.643	0.282	4615V→	830	V	1.687	2.437	2.441	0.312	473445	470	S
1.654 42	2.638 67	2.646 67.20	0.394 10	◆710286	320	N	1.687	2.437	2.441	0.468	480479H	480	H
1.654 42	2.677 68	2.685 68.20	0.315 8	◆426808XX	320	S	1.687	2.500	2.511	1.535	2465	#	S
1.654 42	2.677 68	2.685 68.20	0.394 10	◆426810XX	320	S	1.687	2.502	2.506	0.250	40154S	40S	S
1.654 42	2.756 70	2.764 70.20	0.394 10	◆427010XX	320	S	1.687	2.502	2.508	0.311	410154	410	S
1.654 42	2.835 72	2.843 72.20	0.315 8	◆427208XX	320	S	1.687	2.502	2.508	0.311	450154	450	S
1.654 42	2.835 72	2.845 72.27	0.394 10	◆224270	350	S	1.687	2.502	2.508	0.311	473234	470	S
1.654 42	2.835 72	2.845 72.27	0.394 10	◆427210XX	320	S	1.687	2.502	2.508	0.582	7038SA←	410	S
1.654	2.835	2.846	0.394	710207	400	S	1.687	2.557	2.568	0.464	2146↔	#	S
1.654	2.992	3.003	0.472	710195	400	S	1.687	2.561	2.565	0.500	470460	470	S
1.654 42	2.992 76	2.998 76.15	0.472 12	◆710245→	#	N	1.687	2.605	2.609	0.235	9178S	40S	S
1.654 42	3.150 80	3.157 80.20	0.315 8	◆428008XX	320	S	1.687	2.623	2.629	0.311	473235	470	S
1.654 42	3.150 80	3.157 80.20	0.394 10	◆428010XX	350	S	1.687	2.623	2.629	0.375	440265	440	S
1.654	3.543	3.554	0.374	◆710133	#	N	1.687	2.623	2.629	0.437	8516N	470	N
1.654 42	3.543 90	3.554 90.27	0.469 11.90	◆710246	#	N	1.687	2.650	2.725	0.290	200886	2000E	S
1.654 42	3.543 90	3.554 90.27	0.469 11.90	◆710246	#	N	1.687	2.650	2.725	0.290	200886S	200E	S
							1.687	2.684	2.706	0.250	7381S	240	S
							1.687	2.686	2.691	0.312	474265	470	S
							1.687	2.686	2.690	0.500	470074	470	S
							1.687	2.716	2.720	0.468	450765	450	S
							1.687	2.750	2.756	0.311	473236	470	S

Shaft	Bore	O.D.	Width	Part Number	Style	Matl
1.687	2.835	2.841	0.469	470596	470	S
1.688"						
1.687	2.835	2.841	0.469	470596V	470	V
1.687	2.875	2.879	0.375	473446	470	S
1.687	3.000	3.006	0.375	471981	470	S
1.687	3.062	3.066	0.500	470086	470	S
1.687	3.125	3.130	0.500	470687	470	S
1.687	3.189	3.194	0.437	450533	450	S
1.688"						
1.688	2.328	2.334	0.281	7022S	2760	S
1.688	2.328	2.334	0.313	473317	470	S
1.688	2.551	2.562	0.470	712146	250	S
1.693" 43mm						
1.693	2.126	2.132	0.256	◆224400	250	S
43	54	54.15	6.50			
1.693	2.126	2.132	0.295	◆334111	330	S
43	54	54.15	7.50			
1.693	2.165	2.176	0.236	◆2012S→	320	Y
43	55	55.27	6			
1.693	2.165	2.176	0.236	◆2012V→	320	V
43	55	55.27	6			
1.693	2.165	2.176	0.236	◆710264→	320	Y
43	55	55.27	6			
1.693	2.165	2.176	0.315	◆1183	340	S
43	55	55.27	8			
1.693	2.165	2.173	0.315	◆435508XX	320	S
43	55	55.20	8			
1.693	2.302	2.308	0.295	◆710159	#	S
43	58.47	58.62	7.50			
1.693	2.362	2.373	0.354	◆320583→	320	S
43	60	60.27	9			
1.693	2.441	2.448	0.394	◆224320	470	S
43	62	62.18	10			
1.693	2.480	2.488	0.394	710431	#	S
1.693	2.531	2.565	0.374	710387	470	S
1.693	2.559	2.567	0.315	◆436508XX	320	S
43	65	65.20	8			
1.693	2.756	2.762	0.354	◆710142	#	S
43	70	70.16	9			
1.693	3.622	3.633	0.492	◆710208	#	S
43	92	92.28	12.50			
1.705"						
1.705	3.034	3.040	0.500	710067↔	690	S
1.705	3.034	3.039	0.562	100357	860	V
1.705	3.084	3.090	0.461	3747↔	690	S
1.705	3.084	3.090	0.461	710105↔	#	S
1.709"						
1.709	2.209	2.215	0.354	2955→	710	N

Shaft	Bore	O.D.	Width	Part Number	Style	Matl
1.718"						
1.718	2.437	2.441	0.468	50327	50S	S
1.718	2.561	2.567	0.500	442251	440	S
1.718	2.623	2.627	0.500	450068	450	S
1.718	2.875	2.879	0.468	50081	50S	S
1.718	2.996	3.000	0.375	6101	290	F
1.719"						
1.719	2.561	2.567	0.500	473336	470	S
1.730"						
1.730	2.336	2.342	0.250	6840S	40S	S
1.730	2.336	2.342	0.250	7607	2810	F
1.730	2.336	2.342	0.470	8121S	250	N
1.730	2.401	2.407	0.236	8705S	2770	S
1.732"						
1.732	2.323	2.332	0.268	224450	350	N
1.732	2.362	2.373	0.276	◆224460→	350	X
44	60	60.27	7			
1.732	2.362	2.370	0.276	◆446007XX	320	S
44	60	60.20	7			
1.732	2.362	2.370	0.394	◆446010XX	350	S
44	60	60.20	10			
1.732	2.441	2.452	0.315	◆224462	320	S
44	62	62.28	8			
1.732	2.441	2.451	0.315	◆446208XX↔	320	S
44	62	62.26	8			
1.732	2.441	2.452	0.394	◆224464←	320	N
44	62	62.28	10			
1.732	2.559	2.570	0.394	◆446510XX	350	S
44	65	65.28	10			
1.732	2.559	2.570	0.433	◆224465→	320	S
44	65	65.28	11			
1.732	2.598	2.602	0.236	710223	#	S
1.732	2.677	2.688	0.315	◆350609←	350	N
44	68	68.28	8			
1.732	2.756	2.764	0.315	◆447008XX	320	S
44	70	70.20	8			
1.732	2.835	2.839	0.394	◆447210XX	350	S
44	72	72.11	10			
1.732	3.150	3.161	0.343	◆710115↔	980	S
44	80	80.29	8.70			
1.732	3.543	3.547	0.354	710283	#	N
1.739"						
1.739	2.812	2.818	0.594	8460N	740	N
1.740"						
1.740	3.000	3.008	0.500	6818	710	S

Shaft	Bore	O.D.	Width	Part Number	Style	Matl	Shaft	Bore	O.D.	Width	Part Number	Style	Matl							
1.748"							1.750	2.686	2.692	0.438	450076	450	S							
1.748	2.619	2.627	0.330	4950	880	N	1.750	2.715	2.721	0.437	323119	320	S							
1.748	2.623	2.629	0.313	3227→	830	N	1.750	2.716	2.721	0.406	204002	2040	S							
1.748	3.229	3.236	0.335	3583	830	H	1.750	2.717	2.721	0.406	203002	2030	S							
1.748	3.229	3.236	0.335	3583S	830	H	1.750" 1 3/4"						1.750	2.718	2.728	0.294	200854	2000E	S	
1.750	2.250	2.258	0.187	6703S	350	S	1.750	2.718	2.722	0.359	200354	2000	S	1.750	2.718	2.724	0.359	204038	2040	S
1.750	2.250	2.258	0.250	340400	340	S	1.750	2.750	2.756	0.311	410183N	410	N	1.750	2.750	2.756	0.311	472179	470	S
1.750	2.250	2.254	0.250	42352S	40S	S	1.750	2.750	2.756	0.311	472179A	470	A	1.750	2.750	2.756	0.500	450183	450	S
1.750	2.250	2.254	0.250	710024	#	U	1.750	2.750	2.756	0.500	51083	50S	S	1.750	2.758	2.762	0.375	473447	470	S
1.750	2.250	2.261	0.311	450400	450	S	1.750	2.783	2.787	0.531	50289	50S	S	1.750	2.786	2.876	0.285	200600	2000E	S
1.750	2.328	2.334	0.438	482126	480	S	1.750	2.786	2.876	0.285	200600	2000E	S	1.750	2.810	2.814	0.315	712260	470	S
1.750	2.374	2.379	0.250	204503	2040	S	1.750	2.810	2.814	0.315	712260	470	S	1.750	2.875	2.881	0.252	450291	450	S
1.750	2.374	2.380	0.311	473237	470	S	1.750	2.875	2.881	0.252	450291	450	S	1.750	2.875	2.881	0.252	450291N	450	N
1.750	2.374	2.380	0.311	473237V	470	V	1.750	2.875	2.879	0.375	471141	470	S	1.750	2.875	2.879	0.375	471141	470	S
1.750	2.374	2.380	0.311	7486S	350	S	1.750	2.875	2.880	0.500	6949S	2740	S	1.750	2.983	2.987	0.438	5711	410	S
1.750	2.374	2.378	0.484	710062	#	S	1.750	2.983	2.987	0.438	5711	410	S	1.750	2.983	2.987	0.438	5711S	410	S
1.750	2.411	2.415	0.380	471169	470	S	1.750	2.983	2.987	0.438	5711S	410	S	1.750	2.996	3.001	0.375	473448	470	S
1.750	2.437	2.443	0.313	450351	450	S	1.750	2.996	3.001	0.375	473448	470	S	1.750	3.000	3.005	0.250	204501	2040	S
1.750	2.437	2.443	0.313	470351	470	S	1.750	3.000	3.006	0.374	471984	470	S	1.750	3.061	3.066	0.375	473313	470	S
1.750	2.437	2.443	0.313	471504	470	S	1.750	3.061	3.066	0.375	473313	470	S	1.750	3.061	3.067	0.500	450087	450	S
1.750	2.438	2.444	0.251	43071S	40S	S	1.750	3.061	3.067	0.500	450087	450	S	1.750	3.062	3.066	0.485	710005	860	S
1.750	2.438	2.441	0.375	710013	#	U	1.750	3.062	3.066	0.485	710005	860	S	1.750	3.153	3.159	0.312	482267	480	S
1.750	2.441	2.447	0.374	471831	470	S	1.750	3.189	3.194	0.437	470088	470	S	1.750	3.189	3.194	0.437	470088	470	S
1.750	2.449	2.453	0.312	473157	470	S	1.750	3.371	3.376	0.625	210945	210	S	1.750	3.371	3.376	0.625	210945	210	S
1.750	2.500	2.508	0.375	354040	350	T	1.750	3.543	3.548	0.500	455536	450	S	1.750	3.543	3.548	0.500	455536	450	S
1.750	2.500	2.503	0.484	710389	70S	S	1.750	3.937	3.942	0.312	476820	470	S	1.750	3.937	3.942	0.312	476820	470	S
1.750	2.501	2.507	0.251	40494S	40S	S	1.763"						1.763	2.126	2.134	0.382	1906	310	S	
1.750	2.502	2.508	0.311	450494	450	S	1.765"						1.765	2.412	2.416	0.468	450375	450	S	
1.750	2.502	2.508	0.311	472164	470	S	1.766"						1.766	2.412	2.416	0.468	450375	450	S	
1.750	2.502	2.508	0.311	472164A	470	A	1.766"						1.766	2.412	2.418	0.375	9845→	470	V	
1.750	2.502	2.508	0.311	472164V	470	V	1.766"						1.766	2.412	2.423	0.374	6936S	450	S	
1.750	2.502	2.508	0.311	482164N	480	N	1.766"						1.766	2.412	2.418	0.375	9845→	470	V	
1.750	2.502	2.506	0.406	451147H	450	H	1.766"						1.766	2.412	2.418	0.375	9845→	470	V	
1.750	2.502	2.513	0.500	450352	450	S	1.766"						1.766	2.412	2.418	0.375	9845→	470	V	
1.750	2.502	2.506	0.680	7834	#	S	1.766"						1.766	2.412	2.418	0.375	9845→	470	V	
1.750	2.561	2.567	0.252	204502	2040	S	1.766"						1.766	2.412	2.418	0.375	9845→	470	V	
1.750	2.561	2.566	0.312	472193	470	S	1.766"						1.766	2.412	2.418	0.375	9845→	470	V	
1.750	2.561	2.567	0.500	450361	450	S	1.766"						1.766	2.412	2.418	0.375	9845→	470	V	
1.750	2.561	2.567	0.500	470361	470	S	1.766"						1.766	2.412	2.418	0.375	9845→	470	V	
1.750	2.563	2.569	0.500	205015	2050	F	1.766"						1.766	2.412	2.418	0.375	9845→	470	V	
1.750	2.565	2.571	0.313	324941	320	S	1.766"						1.766	2.412	2.418	0.375	9845→	470	V	
1.750	2.565	2.571	0.313	473796	470	S	1.766"						1.766	2.412	2.418	0.375	9845→	470	V	
1.750	2.621	2.625	0.937	710428	870	V	1.766"						1.766	2.412	2.418	0.375	9845→	470	V	
1.750	2.623	2.629	0.311	472185	470	S	1.766"						1.766	2.412	2.418	0.375	9845→	470	V	
1.750	2.623	2.629	0.313	450070	450	S	1.766"						1.766	2.412	2.418	0.375	9845→	470	V	
1.750	2.686	2.690	0.375	470334	470	S	1.771"						1.771	2.500	2.504	0.359	714075	#	H	
1.771"							1.771	2.500	2.504	0.359	714075	#	H	1.771	2.622	2.628	0.500	354041	350	T
1.771"							1.771	2.622	2.628	0.500	354041	350	T	1.771	3.661	3.661	0.313	1952	540	S
1.771"							1.771	3.661	3.661	0.313	1952	540	S	1.771"						

Shaft	Bore	O.D.	Width	Part Number	Style	Matl
1.772" 45mm						
1.772 45	2.283 58	2.294 58.28	0.276 7	◆455807XX	350	S
1.772 45	2.323 59	2.334 59.28	0.315 8	◆710193	320	S
1.772 45	2.362 60	2.370 60.20	0.276 7	◆456007XX	350	S
1.772 45	2.362 60	2.373 60.27	0.315 8	◆224520	350	S
1.772 45	2.362 60	2.370 60.20	0.315 8	◆456008XX	350	S
1.772 45	2.362 60	2.372 60.25	0.394 10	◆456010XX	350	S
1.772 45	2.362 60	2.372 60.25	0.425 10.80	◆2440	690	N
1.772 45	2.402 61	2.413 61.29	0.315 8	◆710260←	320	S
1.772 45	2.441 62	2.447 62.15	0.236 6	◆494122	490	S
1.772 45	2.441 62	2.452 62.28	0.315 8	◆1012N	320	S
1.772 45	2.441 62	2.452 62.28	0.315 8	◆1012S	350	S
1.772 45	2.441 62	2.453 62.30	0.315 8	◆456208XX	350	S
1.772 45	2.441 62	2.447 62.15	0.315 8	◆710078	470	V
1.772 45	2.441 62	2.445 62.15	0.354 8	710321	470	S
1.772 45	2.520 64	2.531 64.29	0.354 9	◆1938	#	S
1.772 45	2.520 64	2.531 64.29	0.354 9	◆1939	#	S
1.772 45	2.520 64	2.531 64.29	0.354 9	◆1951	870	S
1.772 45	2.559 65	2.565 65.15	0.197 5	◆1992	470	S
1.772 45	2.559 65	2.570 65.28	0.315 8	◆456508XX	350	S
1.772 45	2.598 68	2.608 68.28	0.295 7	710160	#	S
1.772 45	2.638 67	2.644 67.16	0.315 8	◆710289→	320	S
1.772 45	2.677 68	2.688 68.28	0.276 7	◆456807XX	320	S
1.772 45	2.677 68	2.688 68.28	0.335 8.50	◆224560	320	S
1.772 45	2.677 68	2.688 68.28	0.472 12	◆320564→	320	V
1.772 45	2.677 68	2.685 68.20	0.472 12	◆710345	320	S
1.772 45	2.756 70	2.763 70.18	0.394 10	◆457010XX	320	S
1.772 45	2.835 72	2.846 72.29	0.276 7	◆224570	350	S
1.772 45	2.835 72	2.846 72.28	0.276 7	◆457207XX	350	S
1.772 45	2.835 72	2.843 72.20	0.394 10	◆457210XX	350	S

Shaft	Bore	O.D.	Width	Part Number	Style	Matl
1.772 45	2.835 72	2.844 72.25	0.394 10	◆457295XX	320	S
1.772 45	2.835 72	2.846 72.28	0.472 12	◆457212XX	350	S
1.772 45	2.835 72.20	2.843 72.49	0.472 7.50	710270	320	N
1.772 45	2.843 72.20	2.854 72.49	0.295 7.50	◆1943	440	S
1.772 45	2.953 75	2.961 75.20	0.276 7	◆457507XX	320	S
1.772 45	2.953 75	2.959 75.16	0.472 12	◆1979→	470	N
1.772 45	3.071 78	3.077 78.16	0.433 11	◆710248→	660	N
1.772 45	3.150 80	3.161 80.28	0.394 10	◆458010XX	350	S
1.772 45	3.346 85	3.354 85.20	0.394 10	◆458510XX	350	S
1.772 45	3.346 85	3.356 85.25	0.512 13	◆458513XX	450	S
1.772 45	3.858 98	3.865 98.17	0.413 10.50	◆710364↔	#	N
1.781" 1 25/32"						
1.781	2.258	2.269	0.374	321460	320	S
1.781	2.500	2.505	0.312	39925	TFW-H	T
1.781	2.623	2.627	0.500	50266	50S	S
1.781	2.686	2.690	0.500	450269	450	S
1.781	2.750	2.754	0.500	450285	450	S
1.781	2.758	2.762	0.500	450280	450	S
1.781	3.189	3.194	0.437	450089	450	S
1.787"						
1.787	3.229	3.240	0.335	4072→	830	N
1.787	3.229	3.240	0.335	4072N→	830	N
1.796"						
1.796	2.524	2.800	0.599	8314	#	S
1.796	2.524	2.800	0.599	8314S	#	S
1.796	2.725	2.730	0.500	6781	2010	S
1.809"						
1.809	2.361	2.366	0.370	4249	2870	S
1.811" 46mm						
1.811 46	0.108 2.73	2.732 69.40	0.433 11	◆710126	#	S
1.811 46	2.283 58	2.294 58.27	0.276 7	◆224650→	320	N
1.811 46	2.362 60	2.373 60.27	0.276 7	◆224660→	320	H
1.811	2.441	2.445	0.315	224662	350	S

Shaft	Bore	O.D.	Width	Part Number	Style	Matl
1.811	2.441	2.449	0.807	710394	#	S
1.811	2.480	2.491	0.300	224663→	350	N
1.811	2.559	2.567	0.276	◆466507XX	320	S
46	65	65.20	7			
1.811	2.697	2.702	0.295	◆710161	2810	S
46	68.50	68.63	7.50			
1.811	2.732	2.740	0.394	710128	#	S
1.811	2.756	2.764	0.315	◆467008XX	320	S
46	70	70.20	8			
1.811	2.756	2.760	0.315	◆710238→	320	S
46	70	70.10	8			
1.811	3.720	3.728	0.315	710377	#	S
1.812" 1 13/16"						
1.812	2.327	2.332	0.437	444116	440	S
1.812	2.437	2.441	0.468	451817	450	S
1.812	2.437	2.441	0.468	471817	470	S
1.812	2.561	2.566	0.500	203006	2030	S
1.812	2.561	2.566	0.500	203006S	2030	S
1.812	2.562	2.566	0.312	5133	480	V
1.812	2.562	2.567	0.315	39930	TFW-H	T
1.812	2.563	2.567	0.375	39835	TW	T
1.812	2.623	2.627	0.375	472070	470	S
1.812	2.623	2.627	0.455	3618	860	S
1.812	2.686	2.690	0.375	471866	470	S
1.812	2.718	2.722	0.270	7186S	2000	S
1.812	2.750	2.756	0.313	450118	450	S
1.812	2.750	2.754	0.375	473449	470	S
1.812	2.758	2.762	0.500	480281	480	S
1.812	2.777	2.781	0.575	3604→	860	V
1.812	2.875	2.879	0.375	473450V	470	V
1.812	2.875	2.879	0.468	450116	450	S
1.812	3.000	3.006	0.374	7044NA	860	S
1.812	3.000	3.005	0.500	3700	860	S
1.812	3.091	3.097	0.485	4278	860	V
1.812	3.125	3.130	0.375	481992	480	S
1.812	3.189	3.194	0.437	450090	450	S
1.812	4.123	4.128	0.531	6930	210	S
1.813"						
1.813	2.408	-	0.300	710409	#	S
1.813	2.623	2.629	0.433	8181NA↔	740	S
1.813	2.965	2.969	0.250	5070	290	F
1.815"						
1.815	2.562	2.566	0.562	2207	2900	S
1.821"						
1.821	2.623	2.627	0.250	44053	40S	S

Shaft	Bore	O.D.	Width	Part Number	Style	Matl
1.825"						
1.825	2.750	2.754	0.468	7600S	470	S
1.830"						
1.830	2.570	2.574	0.250	6960	40S	S
1.831"						
1.831	3.543	3.551	0.472	710397	#	N
1.840"						
1.840	2.400	2.404	0.235	291295	290	F
1.842"						
1.842	2.748	2.751	0.425	714675	#	V
1.843"						
1.843	2.502	2.506	0.375	471841	470	S
1.843	2.623	2.627	0.375	473451	470	S
1.843	2.750	2.754	0.375	473452	470	S
1.843	2.750	2.756	0.500	470331N	470	N
1.843	2.875	2.879	0.375	473453	470	S
1.850" 47mm						
1.850	2.441	2.449	0.315	◆476208XX	320	S
47	62	62.20	8			
1.850	2.520	2.531	0.236	◆1937	#	S
47	64	64.29	6			
1.850	2.520	2.523	0.276	710191	250	S
1.850	2.559	2.567	0.315	◆476508XX	320	S
47	65	65.20	8			
1.850	2.598	2.602	0.236	◆710215	660	S
47	66	66.10	6			
1.850	2.677	2.688	0.394	◆1187S	320	S
47	68	68.27	10			
1.850	2.677	2.688	0.394	◆476810XX	320	S
47	68	68.27	10			
1.850	2.756	2.764	0.394	◆477010XX	320	S
47	70	70.20	10			
1.850	2.835	2.841	0.315	◆224772	480	S
47	72	72.16	8			
1.850	2.843	2.854	0.236	◆710337	340	S
47	72.20	72.49	6			
1.850	3.150	3.156	0.500	◆710150	#	S
47	80	80.16	12.70			
1.850	3.307	3.318	0.374	◆710143	#	S
47	84	84.28	9.50			
1.850	69.000	2.717	0.398	3606	70S	N

Shaft	Bore	O.D.	Width	Part Number	Style	Matl
1.868"						
1.868	2.518	2.524	0.469	332062→	330	S
1.870"						
1.870	2.781	2.792	0.359	1959	320	S
1.872"						
1.872	3.125	3.131	0.313	473240	470	S
1.873"						
1.873	2.684	2.684	0.544	8521S	2000E	S
1.873	2.716	2.806	0.281	200752	2000E	S
1.875" 1 7/8"						
1.875	-	2.650	0.350	710163	#	S
1.875	2.315	2.316	0.203	8362	330	S
1.875	2.397	2.408	0.250	353120	350	S
1.875	2.397	2.408	0.250	7934S	2040	S
1.875	2.441	2.447	0.325	1949	480	S
1.875	2.470	2.475	0.437	472747	470	S
1.875	2.502	2.511	0.250	340823	340	S
1.875	2.502	2.506	0.315	473454	470	S
1.875	2.502	2.506	0.375	472041	470	S
1.875	2.560	2.565	0.406	2942	470	N
1.875	2.561	2.567	0.313	350936	350	S
1.875	2.561	2.567	0.313	441853	440	S
1.875	2.567	2.561	0.312	490936	#	S
1.875	2.623	2.627	0.250	40071S	40S	S
1.875	2.623	2.629	0.313	472439	470	S
1.875	2.623	2.629	0.313	472439A	470	A
1.875	2.623	2.629	0.313	472439V	470	V
1.875	2.623	2.629	0.375	331227H	330	H
1.875	2.625	2.640	0.433	712102→	TFW-H	T
1.875	2.628	2.633	0.347	6985	290	F
1.875	2.677	2.683	0.374	710211→	740	N
1.875	2.677	2.689	0.551	712516→	#	N
1.875	2.686	2.692	0.313	471868	470	S
1.875	2.716	2.727	0.394	710388↔	320	S
1.875	2.750	2.754	0.250	42421S	40S	S
1.875	2.750	2.756	0.311	450117	450	S
1.875	2.750	2.756	0.311	472572	470	S
1.875	2.758	2.764	0.313	473179	470	S
1.875	2.758	2.762	0.500	6460S	410	S
1.875	2.760	2.766	0.402	6712NA	740	N
1.875	2.782	2.786	0.500	414045	410	S

Shaft	Bore	O.D.	Width	Part Number	Style	Matl
1.875	2.813	2.817	0.500	5126→	740	S
1.875	2.835	2.839	0.375	473455	470	S
1.875	2.868	2.879	0.551	2689S↔	250	S
1.875	2.875	2.881	0.311	450082	450	S
1.875	2.875	2.881	0.311	473238	470	S
1.875	2.875	2.879	0.312	483238V	480	V
1.875	2.875	2.878	0.625	710019	#	U
1.875	2.877	2.864	0.470	9912	250	S
1.875	2.877	2.864	0.470	9912S	250	S
1.875	2.965	2.971	0.234	6064	290	F
1.875	2.996	3.001	0.375	6547	2010	S
1.875	2.996	3.001	0.500	450084	450	S
1.875	3.000	3.006	0.313	450298	450	S
1.875	3.000	3.006	0.313	473239	470	S
1.875	3.000	3.005	0.625	8165	#	H
1.875	3.150	3.155	0.250	715100	#	S
1.875	3.150	3.146	0.930	3186	590	S
1.875	3.150	3.146	0.930	3195	590	S
1.875	3.160	3.165	0.562	6808	45	N
1.875	3.160	3.165	0.672	9316	720	N
1.875	3.160	3.165	0.720	719316	720	V
1.875	3.161	3.165	0.695	100675	720	V
1.875	3.189	3.194	0.375	473458	470	S
1.875	3.251	3.258	0.500	451078	450	S
1.875	3.371	3.376	0.468	410524	410	S
1.875	3.375	4.812	0.312	7105S	#	S
1.875	4.010	4.014	1.000	6127	310	S
1.876"						
1.876	2.561	2.567	0.528	2692→	760	N
1.880"						
1.880	2.562	2.566	0.250	9049	250	S
1.880	2.562	2.566	0.250	9049N	250	S
1.885"						
1.885	2.700	2.706	0.551	9449	740	S
1.886"						
1.886	2.699	2.704	0.350	4333N	790	N
1.886	2.750	2.761	0.469	714503↔	320	N
1.886	2.750	2.765	1.375	4503N↔	790	N
1.890" 48mm						
1.890	2.362 48	2.368 60.15	0.354 9	◆710356→	470	S
1.890	2.441 48	2.452 62.28	0.236 6	◆1188	340	S

Shaft	Bore	O.D.	Width	Part Number	Style	Matl	Shaft	Bore	O.D.	Width	Part Number	Style	Matl	
1.890	2.441	2.452	0.236	◆1188S	340	S	1.890	2.913	2.924	0.394	◆224874	320	S	
48	62	62.28	6				48	74	74.27	10				
1.890	2.441	2.452	0.236	◆710322	340	S								
48	62	62.28	6											
1.890	2.441	2.452	0.276	◆224810	320	N	1.890	2.953	2.961	0.394	◆487510XX	320	S	
48	62	62.28	7				48	75	75.20	10				
1.890	2.441	2.452	0.315	◆224820	320	S	1.890	3.150	3.157	0.315	◆488008XX	320	S	
48	62	62.28	8				48	80	80.20	8				
1.890	2.441	2.445	0.315	◆486208XX	350	S	1.890	3.543	3.551	0.394	◆489010XX	350	S	
48	62	62.10	8				48	90	90.20	10				
1.890	2.441	2.452	0.354	◆1956	#	S	1.890	4.272	4.280	0.512	710296	#	S	
48	62	62.28	9											
1.890	2.441	2.452	0.354	◆1956S	#	S	1.893"							
48	62	62.28	9				1.893	2.434	2.440	0.250	8704S↔	330	S	
1.890	2.441	2.445	0.354	◆710320	480	S	1.929"						49mm	
48	62	62.10	9				1.929	2.441	2.447	0.335	◆4904	660	S	
1.890	2.480	2.484	0.354	1969	470	S	49	62	62.15	8.50				
1.890	2.480	2.484	0.354	◆486309XX	470	S	1.929	2.520	2.531	0.236	◆1936	#	S	
48	63	63.09	9				49	64	64.29	6				
1.890	2.520	2.528	0.394	◆710167	#	S	1.929	2.563	2.567	0.315	39877	TW2	T	
48	64	64.20	10				1.929	2.756	2.767	0.433	◆710305	320	S	
1.890	2.559	2.565	0.319	◆1973	250	S	49	70	70.28	11				
48	65	65.15	8.10				1.929	2.756	2.767	0.433	◆710305S	320	S	
1.890	2.559	2.570	0.354	◆224865	320	S	49	70	70.28	11				
48	65	65.28	9											
1.890	2.559	2.571	0.394	◆486510XX	320	S	1.929	2.843	2.854	0.236	◆710148	970	S	
48	65	65.30	10				49	72.20	72.49	6				
1.890	2.559	2.571	0.394	716484	320	V	49	79	79.10	-				
1.890	2.559	2.565	0.965	◆4528N	660	N	1.929	3.937	3.945	0.315	◆710374	#	S	
48	65	65.15	24.50				49	100	100.20	8				
1.890	2.677	2.688	0.394	◆486810XX	320	N	1.937"						1 15/16"	
48	68	68.27	10				1.937	2.412	2.416	0.468	470409	470	S	
1.890	2.677	2.688	0.433	◆224835→	320	N	1.937	2.437	2.441	0.250	474269	470	S	
48	68	68.28	11				1.937	2.502	2.506	0.375	471195	470	S	
1.890	2.677	2.688	0.433	◆224840→	320	S	1.937	2.502	2.506	0.375	481195	480	S	
48	68	68.28	11				1.937	2.561	2.565	0.500	471854	470	S	
1.890	2.756	2.764	0.315	◆487008XX	350	S	1.937	2.623	2.629	0.313	472319	470	S	
48	70	70.20	8				1.937	2.686	2.697	0.311	3173↔	480	N	
1.890	2.756	2.767	0.354	◆1994	320	S	1.937	2.686	2.692	0.311	471869	470	S	
48	70	70.28	9				1.937	2.686	2.690	0.312	473459	470	S	
1.890	2.756	2.767	0.354	◆487009XX	350	S	1.937	2.686	2.690	0.500	470138V→	470	V	
48	70	70.28	9											
1.890	2.756	2.764	0.354	◆710255	#	S	1.937	2.686	2.690	0.500	6988H	330	H	
48	70	70.20	9				1.937	2.750	2.756	0.313	473241	470	S	
1.890	2.756	2.767	0.354	◆712010→	320	H	1.937	2.758	2.762	0.500	450279	450	S	
48	70	70.28	9				1.937	2.875	2.881	0.313	472144	470	S	
1.890	2.756	2.767	0.472	◆710313→	320	S	1.937	2.875	2.879	0.687	210295	210	S	
48	70	70.28	12											
1.890	2.835	2.847	0.276	1208	320	S	1.937	3.000	3.006	0.311	472394	470	S	
1.890	2.835	2.847	0.276	1208S	320	S	1.937	3.061	3.066	0.375	473461	470	S	
1.890	2.835	2.847	0.276	◆487207XX	320	S	1.937	3.125	3.130	0.375	471391	470	S	
48	72	72.31	7				1.937	3.189	3.194	0.250	40094S	40S	S	
1.890	2.835	2.846	0.335	◆224850	350	S	1.937	3.189	3.194	0.375	473462	470	S	
48	72	72.29	8.50											
1.890	2.835	2.846	0.335	◆224872	320	S	1.937	3.189	3.194	0.437	450094N	450	N	
48	72	72.29	8.50											
1.890	2.874	2.878	0.276	◆224870	470	S								
48	73	73.10	7											
1.890	2.913	2.925	0.394	224815	400	N								

Shaft	Bore	O.D.	Width	Part Number	Style	Matl
1.937	3.189	3.194	0.437	470094	470	S
1.937	3.350	3.355	0.468	450965	450	S
1.937	3.500	3.505	0.250	45653S	40S	S
1.937	3.543	3.548	0.375	417474	410	S
1.937	3.622	3.627	0.375	6074	290	F
1.937	3.751	3.756	0.500	456057	450	S
1.937	3.930	3.935	0.320	710081	#	S

1.938"

1.938	2.562	2.566	0.317	710058	480	S
1.938	2.578	2.583	0.294	9150S	250	S
1.938	2.622	2.628	0.266	5121	2810	S
1.938	2.996	3.002	0.313	473460	470	S
1.937	3.189	3.194	0.437	450094	450	S

1.940"

1.940	2.500	2.502	0.250	6815	2860	S
1.940	2.762	2.768	0.500	2043→	470	S
1.940	2.813	2.817	0.428	8622	#	S
1.940	2.900	2.910	0.400	710281	740	S

1.941"

1.941	2.909	2.915	0.370	3896→	760	S
-------	-------	-------	-------	-------	-----	---

1.945"

1.945	2.891	2.895	0.290	200371	2000	S
-------	-------	-------	-------	--------	------	---

1.968"

1.968	2.623	2.627	0.312	473814	470	S
1.968	2.686	2.690	0.370	7751H	330	H
1.968	2.686	2.690	0.500	450472	450	S
1.968	2.742	2.746	0.500	450911	450	S
1.968	2.742	2.746	0.500	450911N	450	N

1.968	2.960	2.964	0.250	40370S	40S	S
1.968	2.996	3.001	0.500	50528	50S	S
1.968	3.350	3.355	0.468	450111	450	S

1.969" 50mm

1.969	0.101	2.638	0.217	◆710226	320	S
50	2.57	67.00	5.50			
1.969	0.103	2.618	0.512	◆474134	470	S
50	2.62	66.50	13			
1.969	2.362	2.373	0.236	◆710192	320	S
50	60	60.27	6			
1.969	2.441	2.448	0.276	◆225005	320	S
50	62	62.18	7			
1.969	2.441	2.452	0.276	◆506207XX	350	S
50	62	62.28	7			

1.969	2.441	2.446	0.354	◆225008	470	S
50	62	62.13	9			

Shaft	Bore	O.D.	Width	Part Number	Style	Matl
1.969	2.520	2.524	0.256	1971	470	S
1.969	2.524	2.535	0.256	◆710098	710	S
50	64.10	64.39	6.50			
1.969	2.559	2.570	0.315	◆506508XX	320	S
50	65	65.28	8			
1.969	2.559	2.570	0.315	◆710354→	320	N
50	65	65.28	8			

1.969	2.559	2.565	0.354	◆1209	350	S
50	65	65.15	9			
1.969	2.559	2.565	0.354	◆1209S	350	S
50	65	65.15	9			
1.969	2.559	2.565	0.354	◆225010	470	S
50	65	65.15	9			
1.969	2.559	2.565	0.354	◆3743	660	S
50	65	65.15	9			
1.969	2.638	2.646	0.354	◆710357	470	S
50	67	67.20	9			

1.969	2.638	2.649	0.433	◆1974	970	S
50	67	67.29	11			
1.969	2.677	2.681	0.256	◆710194	320	S
50	68	68.10	6.50			
1.969	2.677	2.688	0.315	◆1948	350	S
50	68	68.28	8			
1.969	2.677	2.688	0.315	◆506808XX	350	S
50	68	68.28	8			
1.969	2.677	2.688	0.354	◆225020→	320	V
50	68	68.28	9			

1.969	2.677	2.688	0.354	◆710420→	320	S
50	68	68.28	9			
1.969	2.756	2.760	0.276	◆413818	410	S
50	70	70.10	7			
1.969	2.756	2.764	0.315	◆507008XX	320	S
50	70	70.20	8			
1.969	2.756	2.761	0.354	◆1960	470	S
50	70	70.13	9			
1.969	2.756	2.764	0.354	◆507009XX	320	S
50	70	70.20	9			

1.969	2.756	2.764	0.394	◆710173	#	N
50	70	70.20	10			
1.969	2.756	2.764	0.551	◆710135	#	S
50	70	70.20	14			
1.969	2.835	2.846	0.315	◆225030	350	S
50	72	72.29	8			
1.969	2.835	2.846	0.315	◆507208XX	350	S
50	72	72.28	8			
1.969	2.835	2.846	0.354	◆225035	320	S
50	72	72.29	9			

1.969	2.835	2.843	0.394	◆710398	#	S
50	72	72.20	10			
1.969	2.835	2.846	0.472	◆225040→	320	S
50	72	72.29	12			
1.969	2.874	2.880	0.472	◆450474	450	S
50	73	73.15	12			
1.969	2.913	2.921	0.354	710137	#	S
1.969	2.953	2.961	0.276	◆507507XX	320	S
50	75	75.20	7			

1.969	2.953	2.957	0.354	710437	470	S
1.969	2.953	2.964	0.472	◆507512XX	320	S
50	75	75.28	12			

Shaft	Bore	O.D.	Width	Part Number	Style	Matl
1.969	3.150	3.161	0.315	◆225050	350	S
50	80	80.29	8			
1.969	3.150	3.161	0.315	◆508008XX	350	S
50	80	80.28	8			
1.969	3.150	3.161	0.650	◆710112↔	#	N
50	80	80.30	16.50			
1.969	3.228	3.235	0.315	◆225082	#	S
50	82	82.18	8			
1.969	3.346	3.354	0.315	◆508508XX	320	S
50	85	85.20	8			
1.969	3.386	3.398	0.512	◆710117	400	N
50	86	86.30	13			
1.969	3.543	3.551	0.315	◆509008XX	320	S
50	90	90.20	8			
1.969	3.543	3.554	0.394	◆509010XX	350	S
50	90	90.28	10			
1.969	4.331	4.336	0.374	476512	470	S
1.988"				51mm		
1.988	3.051	3.057	0.551	◆1941	470	S
51	77.50	77.65	14			
1.991"						
1.991	2.900	2.975	0.290	200885	2000E	S
1.996"						
1.996	2.000	2.878	0.250	8998	440	S
1.996	2.743	2.751	0.325	3404	750	H
1.996	3.111	3.120	0.344	4189H	750	H
1.998"						
1.998	2.878	2.882	0.340	4598→	830	N
1.998	2.878	2.884	0.374	320259→	320	V
2.000"				2"		
2.000	2.500	2.504	0.250	710025	#	U
2.000	2.500	2.501	0.375	710040	#	U
2.000	2.500	2.504	0.437	452261H	450	H
2.000	2.501	2.506	0.250	40401	40S	S
2.000	2.502	2.513	0.252	352541	350	S
2.000	2.562	2.568	0.224	4739	2820	S
2.000	2.562	2.568	0.224	8871	2860	S
2.000	2.562	2.566	0.500	205058	2050	S
2.000	2.562	2.566	0.528	331301N	330	N
2.000	2.565	2.571	0.500	9015S	440	S
2.000	2.623	2.627	0.256	710263	320	V
2.000	2.623	2.629	0.260	4148	2860	S
2.000	2.623	2.629	0.311	471424	470	S
2.000	2.623	2.629	0.311	471424A	470	A

Shaft	Bore	O.D.	Width	Part Number	Style	Matl
2.000	2.623	2.629	0.311	471424V	470	V
2.000	2.624	2.630	0.250	40410S	40S	S
2.000	2.624	2.630	0.250	492702	490	S
2.000	2.625	2.631	0.219	9406S	2790	S
2.000	2.630	2.750	0.562	6090S	2730	S
2.000	2.635	2.639	0.235	292594	290	F
2.000	2.686	2.690	0.250	40360S	40S	S
2.000	2.686	2.692	0.374	471870	470	S
2.000	2.686	2.690	0.437	471883	470	S
2.000	2.688	2.690	0.375	710017	#	U
2.000	2.713	2.717	0.468	450446	450	S
2.000	2.716	2.721	0.375	474272	470	S
2.000	2.716	2.720	0.468	470543	470	S
2.000	2.716	2.720	0.593	10543S	10S	S
2.000	2.717	2.721	0.250	43073S	40S	S
2.000	2.720	-	0.210	710365	#	S
2.000	2.742	2.748	0.375	331107N	330	H
2.000	2.742	2.748	0.375	472341	470	S
2.000	2.745	2.751	0.230	5113	2030	S
2.000	2.750	2.754	0.187	5865	40S	S
2.000	2.750	2.756	0.252	40389S	40S	S
2.000	2.750	2.756	0.311	472492	470	S
2.000	2.750	2.756	0.311	472492A	470	A
2.000	2.750	2.756	0.375	450389	450	S
2.000	2.804	2.824	0.294	200881	2000E	S
2.000	2.835	2.839	0.375	472653	470	S
2.000	2.835	2.839	0.375	472653V	470	V
2.000	2.846	2.850	0.375	493524	490	S
2.000	2.875	2.879	0.290	200339	2000	S
2.000	2.875	2.881	0.311	472924	470	S
2.000	2.875	2.881	0.469	450083	450	S
2.000	2.875	2.879	0.703	6163S	210	S
2.000	2.884	2.890	0.311	472082	470	S
2.000	2.961	2.971	0.250	8139	#	F
2.000	2.964	2.965	0.500	205044	2050	F
2.000	2.995	3.002	0.500	410085	410	S
2.000	2.995	3.002	0.500	410085N	410	N
2.000	2.995	3.002	0.500	450085	450	S
2.000	2.995	3.002	0.500	714654	470	N
2.000	2.996	3.002	0.250	40085S	40S	S
2.000	2.996	3.001	0.375	470530	470	S
2.000	3.000	3.005	0.250	40301S	40S	S
2.000	3.000	3.006	0.311	472397	470	S
2.000	3.000	3.006	0.500	450301	450	S
2.000	3.061	3.067	0.375	473463	470	S
2.000	3.062	3.066	0.250	204508	2040	S
2.000	3.125	3.131	0.311	473242	470	S
2.000	3.150	3.155	0.375	412725	410	S
2.000	3.189	3.194	0.375	473464	470	S
2.000	3.189	3.194	0.437	450095	450	S

Shaft	Bore	O.D.	Width	Part Number	Style	Matl
2.000	3.251	3.256	0.437	412027	410	S
2.000	3.350	3.355	0.468	412028	410	S
2.000	3.370	-	1.020	710007	#	S
2.000	3.371	3.378	0.469	410102	410	S
2.000	3.500	3.505	0.500	415627	410	S
2.000	3.543	3.548	0.500	455253	450	S

2.000	3.623	3.628	0.250	204506	2040	S
2.000	3.623	3.628	0.375	487945	480	S
2.000	4.003	4.008	0.468	55524	50S	S

2.008" 51mm

2.008	2.441	2.446	0.276	◆710407	330	S
51	62	62.13	7			
2.008	2.480	2.487	0.236	◆494123	490	S
51	63	63.17	6			
2.008	2.480	2.487	0.236	◆710323	490	S
51	63	63.17	6			
2.008	2.559	2.565	0.276	◆225110	470	S
51	65	65.15	7			
2.008	2.559	2.563	0.276	◆516507XX	470	S
51	65	65.10	7			

2.008	2.756	2.767	0.433	8316→	320	N
2.008	2.756	2.767	0.433	8316N	320	N

2.010"

2.010	2.650	2.655	0.363	3794	490	S
-------	-------	-------	-------	------	-----	---

2.031"

2.031	-	4.156	0.781	5797	#	S
-------	---	-------	-------	------	---	---

2.047" 52mm

2.047	2.441	2.452	0.217	◆710253	#	S
52	62	62.28	5.50			
2.047	2.480	2.489	0.315	◆1975	320	S
52	63	63.23	8			
2.047	2.480	2.489	0.315	◆1975S	320	S
52	63	63.23	8			
2.047	2.559	2.565	0.354	◆1955	350	S
52	65	65.15	9			
2.047	2.559	2.570	0.354	◆225208	320	S
52	65	65.28	9			

2.047	2.559	2.571	0.354	◆526509XX	350	S
52	65	65.30	9			
2.047	2.598	2.603	0.295	◆4898	660	S
52	66	66.12	7.50			
2.047	2.598	2.609	0.354	◆225210	350	N
52	66	66.27	9			
2.047	2.638	2.649	0.276	◆1883	320	S
52	67	67.29	7			
2.047	2.677	2.683	0.256	◆225220	350	S
52	68	68.15	6.50			

2.047	2.677	2.683	0.256	◆710292	#	S
52	68	68.15	6.50			

Shaft	Bore	O.D.	Width	Part Number	Style	Matl
2.047	2.677	2.683	0.295	◆1884	320	S
52	68	68.15	7.50			
2.047	2.677	2.683	0.295	◆710064	#	S
52	68	68.15	7.50			
2.047	2.677	2.688	0.299	◆4990	2810	S
52	68	68.28	7.60			
2.047	2.677	2.688	0.315	◆526808XX	350	S
52	68	68.28	8			

2.047	2.677	2.683	0.315	◆710190	480	V
52	68	68.15	8			
2.047	2.677	2.685	0.512	◆710312	320	S
52	68	68.20	13			
2.047	2.717	2.728	0.394	◆526910XX	350	S
52	69	69.28	10			
2.047	2.756	2.762	0.315	◆225225	470	S
52	70	70.16	8			
2.047	2.756	2.764	0.315	◆527008XX	320	S
52	70	70.20	8			

2.047	2.756	2.767	0.335	◆710187→	320	N
52	70	70.28	8.50			
2.047	2.835	2.846	0.295	◆225540	320	S
52	72	72.29	7.50			
2.047	2.835	2.846	0.303	◆225230	350	S
52	72	72.29	7.70			
2.047	2.835	2.843	0.315	◆527208XX	350	S
52	72	72.20	8			
2.047	2.835	2.846	0.315	◆710242→	320	N
52	72	72.29	8			

2.047	2.953	2.957	0.295	◆225275	660	S
52	75	75.11	7.50			
2.047	2.953	2.964	0.472	◆527512XX	350	S
52	75	75.28	12			
2.047	3.071	3.082	0.354	◆225278	350	N
52	78	78.28	9			
2.047	3.087	3.090	0.386	◆710107	#	S
52	78.40	78.49	9.80			
2.047	3.150	3.161	0.394	◆528010XX↔	320	S
52	80	80.28	10			

2.047	3.228	3.236	0.315	◆528208XX	320	S
52	82	82.20	8			
2.047	3.346	3.354	0.315	◆528507XX	320	S
52	85	85.20	8			

2.048"

2.048	2.728	2.734	0.250	3087	2810	S
-------	-------	-------	-------	------	------	---

2.058"

2.058	3.149	3.154	0.270	200110	2000	S
-------	-------	-------	-------	--------	------	---

2.062" 2 1/16"

2.062	-	4.735	0.468	6077	#	S
2.062	2.561	2.565	0.312	332134	330	S
2.062	2.561	2.565	0.313	484064V	480	V
2.062	2.842	2.846	0.450	5877	50S	S

Shaft	Bore	O.D.	Width	Part Number	Style	Matl	Shaft	Bore	O.D.	Width	Part Number	Style	Matl
2.062	2.996	3.001	0.375	473466	470	S	2.125	2.996	3.002	0.438	450115	450	S
2.062	3.000	3.006	0.311	472012	470	S	2.125	2.996	3.001	0.687	8650S	10S	S
2.062	3.000	3.006	0.313	6954S	440	S	2.125	2.996	3.001	0.750	473467	470	S
2.062	3.000	3.005	0.375	2822V	410	V	2.125	3.000	3.006	0.313	8430S	490	S
2.062	3.000	3.005	0.437	412798N	410	N	2.125	3.000	3.006	0.374	412015V	410	V
2.062	3.061	3.066	0.500	450307	450	S	2.125	3.000	3.005	0.375	472015	470	S
2.062	3.125	3.130	0.500	450311	450	S	2.125	3.000	3.005	0.375	472015V	470	V
2.062	3.151	3.156	0.240	5756	290	F	2.125	3.000	3.006	0.500	450303	450	S
2.062	3.189	3.194	0.437	450096	450	S	2.125	3.000	3.006	0.500	480303	480	S
2.062	3.190	3.194	0.437	416738	410	S	2.125	3.061	3.067	0.500	410308	410	S
2.062	3.250	3.310	0.500	80313	2000E	S	2.125	3.061	3.067	0.500	450308	450	S
2.062	3.251	3.256	0.500	450313	450	S	2.125	3.061	3.067	0.500	470308N	470	N
2.062	3.371	3.376	0.468	450343	450	S	2.125	3.061	3.067	0.500	473468	470	S
2.062	3.623	3.628	0.468	455260	450	S	2.125	3.061	3.066	0.687	30308	30S	S
2.065"							2.125	3.125	3.131	0.374	450312	450	S
2.065	3.130	3.130	0.294	200865	2000E	S	2.125	3.125	3.131	0.374	472016	470	S
2.087"							2.125	3.125	3.130	0.500	410312N	410	N
53mm							2.125	3.126	3.131	0.484	6389	290	F
2.087	0.106	2.685	0.276	◆710175	320	S	2.125	3.146	3.153	0.500	8243	#	F
53	2.69	68.20	7				2.125	3.149	3.154	0.375	476535	470	S
2.093"							2.125	3.189	3.194	0.437	39302	TW-H	T
2.093	2.716	2.725	0.250	340900	340	S	2.125	3.189	3.194	0.437	39717	#	T
2.093	2.716	2.721	0.406	6590S	2040	S	2.125	3.189	3.194	0.437	39719	#	T
2.093	2.750	2.754	0.250	41013S	40S	S	2.125	3.189	3.194	0.437	450121	450	S
2.093	3.150	3.156	0.250	40973S	40S	S	2.125	3.193	3.198	0.812	7790H	#	H
2.125"							2.125	3.251	3.258	0.374	473243	470	S
2 1/8"							2.125	3.350	3.355	0.375	413469	410	S
2.125	2.561	2.565	0.492	474069	470	S	2.125	3.371	3.376	0.312	440972	440	S
2.125	2.750	2.756	0.374	473204	470	S	2.125	3.371	3.372	0.375	413470	410	S
2.125	2.758	2.762	0.437	471950	470	S	2.125	3.371	3.376	0.468	410972N	410	N
2.125	2.835	2.839	0.468	450639	450	S	2.125	3.371	3.376	0.468	410972N	410	N
2.125	2.875	2.881	0.252	40566S	40S	S	2.125	3.436	3.440	0.625	6380	290	F
2.125	2.875	2.881	0.252	6626	440	S	2.125	3.436	3.440	0.625	6380S	290	F
2.125	2.875	2.881	0.252	6626S	40S	S	2.125	3.500	3.505	0.375	416267	410	S
2.125	2.875	2.881	0.374	470898	470	S	2.125	3.543	3.550	0.500	415349	410	S
2.125	2.875	2.881	0.374	470898A	470	A	2.125	3.623	3.628	0.468	455080	450	S
2.125	2.875	2.881	0.375	450365	450	S	2.126"						
2.125	2.875	2.881	0.375	450365N	450	N	54mm						
2.125	2.875	2.881	0.375	450867	450	S	2.126	2.559	2.567	0.315	◆546508XX	320	S
2.125	2.875	2.879	0.437	39851	TFW-H	T	54	65	65.20	8			
2.125	2.875	2.879	0.437	39853	TFW-H	T	2.126	2.559	2.565	0.512	◆2002	470	S
2.125	2.875	2.881	0.437	410867N	410	N	54	65	65.15	13			
2.125	2.875	2.879	0.625	30365	30S	S	2.126	2.598	2.605	0.295	◆225410	#	S
2.125	2.878	2.882	0.375	453066	450	S	54	66	66.17	7.50			
2.125	2.879	2.885	0.500	9599S→	470	S	2.126	2.717	2.726	0.295	◆710239	400	N
2.125	2.880	2.885	0.550	2457←	#	N	54	69	69.23	7.50			
							2.126	2.835	2.844	0.394	◆225420	320	S
							54	72	72.25	10			
							2.126	2.835	2.844	0.394	◆547210XX	320	S
							54	72	72.25	10			
							2.126	2.874	2.882	0.315	◆547308XX	320	S
							54	73	73.20	8			
							2.126	2.874	2.890	0.502	712125→	TFW-H	T

Shaft	Bore	O.D.	Width	Part Number	Style	Matl
2.126	2.972	2.983	0.709	◆710073	#	S
54	75.50	75.78	18			
2.126	2.992	3.000	0.551	710438	#	S
<hr/>						
2.126	3.228	3.240	0.315	◆225450	320	S
54	82	82.30	8			
2.126	3.228	3.242	0.394	◆548210XX	320	S
54	82	82.35	10			
2.126	3.346	3.356	0.394	225460	320	S
2.126	3.346	3.357	0.394	◆548510XX	320	S
54	85	85.28	10			
<hr/>						
2.129"						
2.129	2.891	2.895	0.250	42101S	40S	S
<hr/>						
2.136"						
2.136	2.902	2.909	0.310	8312	2720	S
2.136	2.902	2.909	0.310	8312S	2720	S
<hr/>						
2.156" 2 5/32"						
2.156	2.880	2.885	0.375	100058	TW	T
2.156	3.189	3.196	0.437	450621	450	S
2.156	3.251	3.256	0.500	450869	450	S
<hr/>						
2.165" 55mm						
2.165	2.677	2.683	0.256	◆710127	#	S
55	68	68.15	6.50			
2.165	2.677	2.688	0.315	◆225500	320	S
55	68	68.28	8			
2.165	2.677	2.688	0.315	◆556808XX	320	S
55	68	68.28	8			
2.165	2.756	2.761	0.354	152807XX	320	S
55	70	70.13	9			
<hr/>						
2.165	2.756	2.761	0.354	◆3723	660	S
55	70	70.13	9			
2.165	2.835	2.844	0.315	◆225530	350	S
55	72	72.24	8			
2.165	2.835	2.844	0.315	◆557208XX	350	S
55	72	72.25	8			
2.165	2.835	2.846	0.394	◆225535	320	S
55	72	72.29	10			
2.165	2.913	2.920	0.236	◆1207	490	S
55	74	74.17	6			
<hr/>						
2.165	2.913	2.920	0.236	◆1207N	490	S
55	74	74.17	6			
2.165	2.953	2.961	0.276	◆55X1007X	320	S
55	75	75.20	7			
2.165	2.953	2.961	0.315	◆557508XX	350	S
55	75	75.20	8			
2.165	2.953	2.962	0.394	◆225545	350	S
55	75	75.24	10			
2.165	2.953	2.967	0.394	◆557510XX	350	S
55	75	75.35	10			
<hr/>						
2.165	3.071	3.082	0.394	◆557810XX	350	S
55	78	78.28	10			

Shaft	Bore	O.D.	Width	Part Number	Style	Matl
2.165	3.150	3.161	0.315	◆558008XX	350	S
55	80	80.28	8			
2.165	3.228	3.235	0.394	◆1958	350	S
55	82	82.17	10			
2.165	3.228	3.240	0.472	◆558212XX	350	S
55	82	82.30	12			
2.165	3.346	3.359	0.394	◆558510XX	350	S
55	85	85.31	10			
<hr/>						
2.165	3.465	3.472	0.315	◆558808XX↔	320	S
55	88	88.20	8			
2.165	3.543	3.554	0.512	◆559013XX	350	S
55	90	90.28	13			
2.165	3.937	3.949	0.500	◆55X10013X	450	S
55	100	100.30	12.70			
<hr/>						
2.167" 55mm						
2.167	2.756	2.767	0.315	◆557008XX	350	S
55	70	70.27	8			
<hr/>						
2.172"						
2.172	3.125	3.130	0.675	710413	#	N
<hr/>						
2.180"						
2.180	2.999	3.003	0.250	4740	2820	S
2.180	3.000	3.006	0.500	8974S	490	S
2.180	3.190	3.194	0.620	713103→	690	V
<hr/>						
2.187" 2 3/16"						
2.187	2.835	2.839	0.468	471952	470	S
2.187	2.875	2.881	0.374	450489	450	S
2.187	2.875	2.881	0.374	473244	470	S
2.187	2.996	3.001	0.375	472234	470	S
2.187	3.000	3.006	0.374	472018	470	S
<hr/>						
2.187	3.062	3.066	0.375	473471	470	S
2.187	3.125	3.131	0.375	472020	470	S
2.187	3.187	3.194	0.687	6636S	350	S
2.187	3.189	3.194	0.437	470354	470	S
2.187	3.189	3.194	0.718	6186	10S	S
<hr/>						
2.187	3.251	3.258	0.374	473245	470	S
2.187	3.350	3.355	0.375	412943	410	S
2.187	3.371	3.376	0.375	413472	410	S
2.187	3.500	3.505	0.375	416268	410	S
2.187	3.623	3.628	0.468	415350	410	S
<hr/>						
2.188"						
2.188	3.188	3.199	0.618	3103→	690	S
<hr/>						
2.199"						
2.199	3.519	3.523	0.590	2286	740	S

Shaft	Bore	O.D.	Width	Part Number	Style	Matl
2.200"						
2.200	2.804	-	0.300	710171	#	N
2.200	3.022	3.028	0.422	4741←	#	N
2.201"						
2.201	2.735	2.741	0.197	3553	2840	S
2.205" 56mm						
2.205	2.598	2.606	0.669	◆710382	#	S
56	66	66.20	17			
2.205	2.677	2.683	0.177	◆1932	490	S
56	68	68.15	4.50			
2.205	2.677	2.683	0.177	◆1932S	490	S
56	68	68.15	4.50			
2.205	2.677	2.682	0.394	◆566810XX	480	N
56	68	68.12	10			
2.205	2.756	2.764	0.315	◆567008XX	350	S
56	70	70.20	8			
2.205	2.835	2.843	0.276	◆567207XX	320	S
56	72	72.20	7			
2.205	2.835	2.843	0.315	710393	#	S
2.205	2.835	2.840	0.354	◆225650	320	S
56	72	72.14	9			
2.205	2.835	2.841	0.429	◆710069	#	S
56	72	72.16	10.90			
2.205	2.835	2.850	0.453	◆56X72115XX	350	S
56	72	72.40	11.50			
2.205	2.835	2.845	0.492	◆225227	#	S
56	72	72.27	12.50			
2.205	2.874	2.880	0.295	◆1993	470	S
56	73	73.15	7.50			
2.205	2.874	2.880	0.295	◆225673	#	S
56	73	73.15	7.50			
2.205	2.913	2.920	0.335	◆710176	870	S
56	74	74.17	8.50			
2.205	2.921	2.928	0.256	◆710125	#	S
56	74.20	74.37	6.50			
2.205	2.953	2.958	0.260	◆4899	660	S
56	75	75.13	6.60			
2.205	2.953	2.966	0.276	◆225775	#	S
56	75	75.33	7			
2.205	2.953	2.961	0.276	◆567507XX	320	S
56	75	75.20	7			
2.205	2.992	2.998	0.193	◆710108	660	S
56	76	76.15	4.90			
2.205	3.071	3.082	0.295	◆225678	#	S
56	78	78.28	7.50			
2.205	3.150	3.161	0.315	◆568008XX	320	S
56	80	80.28	8			
2.205	3.228	3.236	0.315	◆568208XX	320	S
56	82	82.20	8			
2.205	3.346	3.357	0.315	◆568508XX	350	S
56	85	85.28	8			
2.205	3.465	3.472	0.315	◆568808XX	320	S
56	88	88.20	8			

Shaft	Bore	O.D.	Width	Part Number	Style	Matl
2.205	3.543	3.551	0.315	◆569008XX	320	S
56	90	90.20	8			
2.205	4.803	4.813	0.315	710086	#	S
2.218"						
2.218	3.350	3.355	0.468	50631	50S	S
2.222"						
2.222	3.543	3.548	0.760	7568	#	H
2.240"						
2.240	2.992	2.998	0.255	710183	660	S
2.240	3.190	3.194	0.450	3095	690	S
2.244" 57mm						
2.244	2.638	2.649	0.236	◆1984	250	S
57	67	67.29	6			
2.244	2.835	2.840	0.331	◆1964	470	S
57	72	72.14	8.40			
2.244	3.031	3.039	0.315	◆710129	#	S
57	77	77.20	8			
2.244	3.110	3.120	0.539	◆710072	#	S
57	79	79.25	13.70			
2.244	3.110	3.120	0.539	◆710074	#	S
57	79	79.25	13.70			
2.244	3.150	3.154	0.315	710225	#	S
2.244	3.189	3.196	0.315	◆1928	470	S
57	81	81.18	8			
2.244	3.346	3.354	0.512	◆578513XX	320	S
57	85	85.20	13			
2.248"						
2.248	2.996	3.002	0.500	450441	450	S
2.250" 2 1/4"						
2.250	-	2.840	0.500	710045	VS1	S
2.250	2.625	2.636	0.187	341022	340	S
2.250	2.675	2.720	0.539	722109	VS1	S
2.250	2.750	2.754	0.250	710026	#	U
2.250	2.875	2.879	0.250	43034S	40S	S
2.250	2.996	3.001	0.437	471341	470	S
2.250	2.996	3.001	0.437	471341N	470	N
2.250	3.000	3.006	0.250	40520S	40S	S
2.250	3.000	3.006	0.374	410520	410	S
2.250	3.000	3.006	0.374	471272	470	S
2.250	3.000	3.006	0.374	471272N	470	N
2.250	3.000	3.005	0.375	712250	470	V
2.250	3.000	3.005	0.438	483323V	480	V
2.250	3.035	3.046	0.374	352637	350	S

Shaft	Bore	O.D.	Width	Part Number	Style	Matl
2.250	3.061	3.067	0.375	473473	470	S
2.250	3.061	3.066	0.500	7937N	410	N
2.250	3.125	3.130	0.250	40433S	40S	S
2.250	3.125	3.131	0.374	471138	470	S
2.250	3.188	3.195	0.438	450737	450	S
2.250	3.188	3.195	0.438	470737	470	S
2.250	3.188	3.195	0.438	470737N	470	N
2.250	3.189	3.149	0.437	30737	410	S
2.250	3.189	3.194	0.437	410737	410	S
2.250	3.189	3.194	0.437	50737	50S	S
2.250	3.249	3.250	0.285	200763	2000E	S
2.250	3.251	3.258	0.251	40316S	40S	S
2.250	3.251	3.258	0.374	472636	470	S
2.250	3.251	3.258	0.500	410316	410	S
2.250	3.251	3.258	0.500	450316	450	S
2.250	3.252	3.260	0.551	712512←	#	N
2.250	3.310	3.317	0.375	44052	40S	S
2.250	3.350	3.355	0.312	454136N	450	N
2.250	3.350	3.355	0.375	411253	410	S
2.250	3.350	3.357	0.469	450099	450	S
2.250	3.371	3.378	0.374	412920	410	S
2.250	3.371	3.378	0.374	412920V	410	V
2.250	3.371	3.378	0.374	442109	440	S
2.250	3.371	3.378	0.438	450132	450	S
2.250	3.400	3.700	0.280	200929	2000E	S
2.250	3.443	3.447	0.250	41075S	40S	S
2.250	3.481	3.486	0.500	455136	450	S
2.250	3.500	3.505	0.375	411376	410	S
2.250	3.500	3.505	0.500	455093	450	S
2.250	3.543	3.548	0.500	416270	410	S
2.250	3.623	3.628	0.468	475234N	470	N
2.250	3.623	3.630	0.469	415234	410	S
2.250	3.750	3.757	0.500	415259	410	S
2.250	3.876	3.881	0.468	55337	50S	S
2.250	4.003	4.010	0.469	415254	410	S
2.250	4.064	4.069	1.092	722250	900	N
2.250	4.064	4.069	1.092	722250S	900	N
2.272"						
2.272	2.654	2.661	0.250	39821	TW	T
2.281"						
2.281	3.154	3.161	0.375	493291	490	S
2.283"						
						58mm
2.283	2.835	2.846	0.315	◆587208XX	350	S
58	72	72.28	8			

Shaft	Bore	O.D.	Width	Part Number	Style	Matl
2.283	2.874	2.878	0.335	710439	#	S
2.283	2.913	2.924	0.394	◆710271←	320	S
58	74	74.27	10			
2.283	2.913	2.918	0.512	◆225874	1010	N
58	74	74.12	13			
2.283	2.953	2.961	0.276	710136	#	S
2.283	2.953	2.964	0.354	◆225875	320	S
58	75	75.29	9			
2.283	2.953	2.959	0.354	◆710400	470	S
58	75	75.16	9			
2.283	2.953	2.964	0.433	◆587511XX	350	S
58	75	75.28	11			
2.283	2.992	3.001	0.307	◆710230	#	S
58	76	76.23	7.80			
2.283	3.031	3.042	0.335	◆225877	350	N
58	77	77.27	8.50			
2.283	3.071	3.082	0.394	◆710144←	#	S
58	78	78.28	10			
2.283	3.150	3.161	0.315	◆225880	350	S
58	80	80.29	8			
2.283	3.150	3.161	0.315	◆588008XX	350	S
58	80	80.28	8			
2.283	3.346	3.356	0.512	◆588513XX	320	S
58	85	85.25	13			
2.283	3.465	3.472	0.315	◆588808XX	320	S
58	88	88.20	8			
2.283	3.543	3.554	0.394	◆589010XX	350	S
58	90	90.28	10			
2.283	4.055	4.063	0.433	710268	400	N
2.293"						
2.293	3.148	3.154	0.358	204035	2040	S
2.296"						
2.296	3.148	3.153	0.359	205035	2050	F
2.312" 2 5/16"						
2.312	3.000	3.004	0.375	4131	2870	S
2.312	3.000	3.005	0.500	411160V	410	V
2.312	3.065	3.070	0.281	43109S	40S	S
2.312	3.251	3.256	0.375	411394	410	S
2.312	3.313	3.318	0.375	5924	40S	S
2.312	3.350	3.355	0.375	410694	410	S
2.312	3.371	3.376	0.468	450133	450	S
2.312	3.500	3.505	0.375	416444	410	S
2.312	3.751	3.756	0.500	455321	450	S
2.313"						
2.313	3.125	3.131	0.375	472150	470	S
2.313	3.251	3.258	0.500	450317	450	S

Shaft	Bore	O.D.	Width	Part Number	Style	Matl
2.314"						
2.314	3.000	3.006	0.382	442874	440	S
2.321"						
2.321	3.000	3.004	0.313	493629	490	S
2.323" 59mm						
2.323	2.953	2.957	0.394	◆710168	470	S
	59	75	75.11	10		
2.323	3.083	3.093	0.315	710229	400	S
2.323	3.083	3.093	0.315	710231	320	S
2.323	3.937	3.948	0.394	◆710121	#	N
	59	100	100.28	10		
2.325"						
2.325	3.125	3.130	0.313	710430	#	S
2.325	3.375	3.390	0.375	712101→	TFW-H	T
2.328"						
2.328	3.000	3.006	0.375	332271N	330	N
2.328	3.000	3.006	0.375	3945	480	N
2.328	3.000	3.006	0.375	3946	860	S
2.328	3.000	3.006	0.375	493637	490	S
2.362" 60mm						
2.362	2.835	2.841	0.295	◆710379	470	S
	60	72	72.16	7.50		
2.362	2.835	2.846	0.315	◆607208XX	350	S
	60	72	72.28	8		
2.362	2.913	2.917	0.394	226001←	250	V
2.362	2.953	2.959	0.228	◆710093	#	S
	60	75	75.16	5.80		
2.362	2.953	2.964	0.315	◆607508XX	350	S
	60	75	75.28	8		
2.362	2.953	2.964	0.354	◆226015←	320	N
	60	75	75.29	9		
2.362	2.953	2.972	0.394	712113→	TFW-H	T
2.362	3.071	3.082	0.354	◆226018	350	N
	60	78	78.28	9		
2.362	3.150	3.161	0.315	◆1039S	350	S
	60	80	80.29	8		
2.362	3.150	3.157	0.315	◆608008XX	350	S
	60	80	80.20	8		
2.362	3.150	3.157	0.315	710333	320	S
2.362	3.228	3.236	0.276	◆608207XX	320	S
	60	82	82.20	7		
2.362	3.228	3.239	0.472	◆2001←	320	S
	60	82	82.27	12		
2.362	3.228	3.240	0.472	◆608212XX	350	S
	60	82	82.30	12		

Shaft	Bore	O.D.	Width	Part Number	Style	Matl
2.362	3.228	3.236	0.472	710350	#	V
2.362	3.228	3.236	0.472	◆710390→	320	N
	60	82	82.20	12		
2.362	3.228	3.239	0.472	◆712006←	320	H
	60	82	82.27	12		
2.362	3.346	3.357	0.315	◆608508XX	350	S
	60	85	85.28	8		
2.362	3.346	3.354	0.472	◆608512XX	320	S
	60	85	85.20	12		
2.362	3.386	3.393	0.276	◆710182	660	S
	60	86	86.18	7		
2.362	3.543	3.553	0.315	◆609008XX	320	S
	60	90	90.25	8		
2.362	3.543	3.554	0.394	◆609010XX	350	S
	60	90	90.27	10		
2.362	3.543	3.550	0.551	◆1985	480	S
	60	90	90.17	14		
2.362	3.543	3.550	0.551	◆1985S	480	S
	60	90	90.17	14		
2.362	3.740	3.748	0.315	◆609508XX	320	S
	60	95	95.20	8		
2.362	3.937	3.945	0.394	◆60X10010XX↔	320	N
	60	100	100.20	10		
2.362	4.055	4.062	0.472	◆710276	400	N
	60	103	103.18	12		
2.362	4.331	4.339	0.315	◆60X11008XX	320	S
	60	110	110.20	8		
2.367"						
2.367	3.366	3.374	0.257	4539H	750	H
2.374"						
2.374	3.350	3.357	0.251	442507	440	S
2.375" 2 3/8"						
2.375	-	3.375	0.510	353890	350	S
2.375	2.875	2.879	0.375	710041	#	U
2.375	2.996	3.001	0.500	470764	470	S
2.375	3.000	3.005	0.250	41026S	40S	S
2.375	3.000	3.005	0.375	473573	470	S
2.375	3.002	3.013	0.437	3393←	320	V
2.375	3.061	3.067	0.375	473474	470	S
2.375	3.061	3.066	0.500	480988H	480	H
2.375	3.125	3.131	0.374	470565	470	S
2.375	3.189	3.194	0.375	473475	470	S
2.375	3.251	3.258	0.374	413246	410	S
2.375	3.251	3.256	0.375	483246N	480	N
2.375	3.251	3.256	0.437	412038N	410	N
2.375	3.251	3.256	0.500	470574N	470	N
2.375	3.251	3.256	0.625	710210	740	V
2.375	3.252	3.256	0.500	480574H	480	H
2.375	3.265	3.270	0.495	5119	490	S

Shaft	Bore	O.D.	Width	Part Number	Style	Matl
2.375	3.350	3.355	0.250	40101S	40S	S
2.375	3.350	3.355	0.375	412119	410	S
2.375	3.350	3.355	0.438	472856	470	S
<hr/>						
2.375	3.350	3.355	0.468	410101N	410	N
2.375	3.350	3.357	0.469	450101	450	S
2.375	3.371	3.378	0.375	413247	410	S
2.375	3.371	3.378	0.469	450350	450	S
2.375	3.471	3.616	0.290	200855	2000E	S
<hr/>						
2.375	3.471	3.616	0.290	200855S	200E	S
2.375	3.481	3.486	0.437	470987	470	S
2.375	3.483	3.490	0.500	410686N	410	N
2.375	3.483	3.490	0.500	410987	410	S
2.375	3.483	3.490	0.500	450103	450	S
<hr/>						
2.375	3.483	3.490	0.500	450686	450	S
2.375	3.500	3.507	0.374	416271	410	S
2.375	3.500	3.507	0.374	416271A	410	A
2.375	3.500	3.505	0.375	475095	470	S
2.375	3.500	3.505	0.375	475095N	470	N
<hr/>						
2.375	3.543	3.550	0.500	412861	410	S
2.375	3.543	3.548	0.500	415248N	410	N
2.375	3.601	3.608	0.437	415857	410	S
2.375	3.623	3.628	0.375	410825	410	S
2.375	3.623	3.628	0.468	475380N	470	N
<hr/>						
2.375	3.623	3.628	0.500	456472N	450	N
2.375	3.751	3.756	0.500	416071	410	S
2.375	3.875	3.881	1.060	711553	740	N
2.375	3.876	3.881	0.375	417480	410	S
2.375	3.876	3.883	0.468	455860	450	S
<hr/>						
2.375	4.064	4.069	1.092	712375	900	N
2.375	4.498	4.504	0.391	714512	870	N
2.375	4.500	4.504	1.060	710006→	740	N
<hr/>						
2.402"				61mm		
2.402	2.992	3.003	0.276	◆226150	#	S
61	76	76.28	7			
<hr/>						
2.420"						
2.420	3.000	3.006	0.394	4160	2810	S
<hr/>						
2.432"						
2.432	3.070	3.075	0.227	4019N	470	N
<hr/>						
2.437"				2 7/16"		
2.437	3.125	3.130	0.375	471887	470	S
2.437	3.350	3.355	0.375	411500	410	S
2.437	3.371	3.376	0.375	413478	410	S
2.437	3.481	3.486	0.500	450104	450	S

Shaft	Bore	O.D.	Width	Part Number	Style	Matl
2.437	3.500	3.505	0.375	411245	410	S
<hr/>						
2.437	3.500	3.505	0.500	455096	450	S
2.437	3.543	3.548	0.375	417073	410	S
2.437	3.624	3.628	0.375	3210	490	S
<hr/>						
2.438"						
2.438	3.251	3.258	0.438	412040	410	S
<hr/>						
2.441"				62mm		
2.441	3.071	3.077	0.374	◆710213	2810	S
62	78	78.16	9.50			
2.441	3.150	3.157	0.315	◆628009XX	320	S
62	80	80.20	9			
2.441	3.150	3.161	0.394	◆628010XX	350	S
62	80	80.28	10			
2.441	3.346	3.353	0.315	◆226285	410	S
62	85	85.17	8			
2.441	3.346	3.352	0.315	◆628508XX	410	S
62	85	85.13	8			
<hr/>						
2.441	3.543	3.554	0.394	◆629010XX	350	S
62	90	90.28	10			
2.441	3.937	3.949	0.276	◆62X10007XX	320	S
62	100	100.30	7			
<hr/>						
2.468"						
2.468	3.350	3.355	0.468	50560	50S	S
<hr/>						
2.474"						
2.474	3.543	3.548	0.285	6575S	2000	S
<hr/>						
2.480"				63mm		
2.480	3.310	3.316	0.500	6785	350	F
2.480	3.346	3.357	0.394	◆638510XX	320	S
63	85	85.28	10			
2.480	3.543	3.550	0.276	◆1935	470	S
63	90	90.17	7			
2.480	3.543	3.549	0.394	◆639010XX	320	S
63	90	90.14	10			
<hr/>						
2.485"						
2.485	3.165	2.488	0.188	710042	#	U
<hr/>						
2.496"						
2.496	3.672	3.772	0.315	200851	2000E	S
<hr/>						
2.497"						
2.497	3.245	3.248	0.485	5109	#	S

Shaft	Bore	O.D.	Width	Part Number	Style	Matl
2.500"		2 1/2"				
2.500	3.000	3.005	0.250	40555	40S	S
2.500	3.000	3.005	0.250	40555S	40S	S
2.500	3.000	3.004	0.313	710027	#	U
2.500	3.000	3.015	0.375	710034	#	U
2.500	3.125	3.130	0.250	43290S	40S	S
2.500	3.125	3.130	0.547	9946N	#	N
2.500	3.130	3.135	0.315	39803	TFW-H	T
2.500	3.148	3.154	0.250	40337S	40S	S
2.500	3.150	3.155	0.315	473476	470	N
2.500	3.189	3.194	0.375	472029	470	S
2.500	3.226	3.231	0.190	3942	2840	S
2.500	3.250	3.255	0.375	710018	#	U
2.500	3.251	3.258	0.374	410519	410	S
2.500	3.251	3.258	0.374	410752	410	S
2.500	3.251	3.258	0.374	471271A	470	A
2.500	3.251	3.258	0.374	471271V	470	V
2.500	3.251	3.258	0.437	450519	450	S
2.500	3.251	3.256	0.500	480519	480	S
2.500	3.252	3.259	0.250	442380	440	S
2.500	3.297	3.304	0.327	4250↔	740	S
2.500	3.350	3.357	0.437	450496	450	S
2.500	3.350	3.355	0.468	410496	410	S
2.500	3.371	3.378	0.374	470605	470	S
2.500	3.371	3.435	0.500	80330	80S	S
2.500	3.428	3.435	0.375	473274	470	S
2.500	3.428	3.435	0.375	473274N	470	N
2.500	3.499	3.505	0.500	3894V	480	V
2.500	3.499	3.506	0.500	7581H	480	H
2.500	3.500	3.507	0.250	444042	440	S
2.500	3.500	3.507	0.374	415449	410	S
2.500	3.500	3.507	0.374	415449V	410	V
2.500	3.500	3.504	0.450	714670	470	N
2.500	3.500	3.507	0.500	415147	410	S
2.500	3.500	3.507	0.500	415147N	410	N
2.500	3.500	3.507	0.500	455147	450	S
2.500	3.542	3.549	0.500	455001	450	S
2.500	3.542	3.549	0.500	455001S	450	S
2.500	3.543	3.548	0.500	415001	410	S
2.500	3.543	3.548	0.500	415001N	410	N
2.500	3.543	3.548	0.500	475001	470	S
2.500	3.623	3.630	0.374	416273	410	S
2.500	3.623	3.630	0.374	455369	450	S
2.500	3.750	3.757	0.500	455079	450	S
2.500	3.876	3.881	0.468	415082	410	S
2.500	3.876	3.881	0.468	415082N	410	N
2.500	4.003	4.008	0.468	455655	450	S

Shaft	Bore	O.D.	Width	Part Number	Style	Matl
2.500	4.035	4.040	0.634	4525V	720	V
2.500	4.250	4.260	0.500	355732	350	S
2.500	4.500	6.125	0.400	7512SSO	510	S
2.500	4.938	4.943	0.500	3136N	470	N
2.503"						
2.503	3.428	3.239	0.709	4561V←	#	V
2.503	3.629	3.633	0.900	4624V	860	V
2.512"						
2.512	3.506	3.519	0.290	8975S	490	S
2.520"						
2.520	2.992	3.000	0.276	710256	#	S
2.520	3.031	3.039	0.315	♦710130	#	S
64	77	77.20	8			
2.520	3.150	3.158	0.315	♦226480→	330	H
64	80	80.21	8			
2.520	3.150	3.161	0.315	♦648008XX	320	S
64	80	80.28	8			
2.520	5.197	5.201	0.512	710277	#	N
2.531"						
2.531	4.540	6.125	0.500	7154S	#	S
2.556"						
2.556	3.937	3.942	0.375	476514	470	S
2.559"						
65mm						
2.559	3.150	3.161	0.315	♦658008XX	320	S
65	80	80.28	8			
2.559	3.189	3.200	0.276	♦226510→	320	Y
65	81	81.28	7			
2.559	3.228	3.235	0.276	♦710094	660	S
65	82	82.17	7			
2.559	3.307	3.318	0.354	♦712005→	320	H
65	84	84.28	9			
2.559	3.346	3.354	0.315	♦658508XX	350	S
65	85	85.20	8			
2.559	3.346	3.355	0.394	♦226520	350	S
65	85	85.22	10			
2.559	3.346	3.357	0.394	♦658510XX	350	S
65	85	85.27	10			
2.559	3.346	3.353	0.394	♦710373	470	S
65	85	85.17	10			
2.559	3.465	3.472	0.315	♦658808XX	350	S
65	88	88.20	8			
2.559	3.465	3.472	0.394	♦658810XX	320	S
65	88	88.20	10			
2.559	3.465	3.472	0.472	♦710367→	400	S
65	88	88.20	12			

Shaft	Bore	O.D.	Width	Part Number	Style	Matl
2.559 65	3.543 90	3.551 90.20	0.276 7	◆659007XX	320	S
2.559 65	3.543 90	3.554 90.27	0.394 10	◆226530	350	S
2.559 65	3.543 90	3.554 90.28	0.394 10	◆659010XX	350	S
2.559 65	3.543 90	3.551 90.20	0.512 13	◆659013XX	350	S

2.559 65	3.937 100	3.949 100.30	0.276 7	◆65X10007XX	320	S
2.559 65	3.937 100	3.948 100.28	0.394 10	◆65X10010XX	350	S

2.560"

2.560	3.090	3.095	0.256	5123	2800	S
--------------	-------	-------	-------	------	------	---

2.562"

2 9/16"

2.562	3.481	3.486	0.375	413479	410	S
2.562	3.500	3.505	0.375	415302	410	S
2.562	3.500	3.505	0.500	415098N	410	N
2.562	3.543	3.548	0.500	455311	450	S
2.562	3.623	3.625	0.375	415988	410	S

2.562	3.727	3.777	0.490	9943	#	S
2.562	3.750	3.756	0.375	417481	410	S
2.562	3.876	3.881	0.468	455280	450	S

2.598"

66mm

2.598 66	3.150 80	3.154 80.11	0.354 9	◆226610	410	N
2.598 66	3.346 85	3.353 85.17	0.315 8	◆710092	410	S
2.598	3.481	3.488	0.438	411330	410	S
2.598	3.481	3.488	0.438	411330N	410	N
2.598	3.999	4.004	0.780	712598	470	S

2.598	3.999	4.004	0.780	712598S	470	S
2.598	4.000	4.005	0.500	477069	470	S

2.625"

2 5/8"

2.625	3.350	3.355	0.375	412871	410	S
2.625	3.350	3.356	0.468	450329	450	S
2.625	3.371	3.376	0.250	440511	440	S
2.625	3.371	3.378	0.438	410708	410	S
2.625	3.371	3.378	0.438	413248	410	S

2.625	3.371	3.378	0.438	450626	450	S
2.625	3.481	3.486	0.500	450412	450	S
2.625	3.484	3.489	0.250	43077S	40S	S
2.625	3.500	3.507	0.374	415483	410	S
2.625	3.500	3.507	0.374	455368	450	S

2.625	3.500	3.505	0.500	475368N	470	N
2.625	3.516	3.533	0.394	712103→	TPDW	T
2.625	3.543	3.548	0.375	417079	410	S

Shaft	Bore	O.D.	Width	Part Number	Style	Matl
2.625	3.623	3.630	0.374	415458	410	S
2.625	3.623	3.630	0.374	415458V	410	V

2.625	3.623	3.630	0.374	475458	470	S
2.625	3.623	3.628	0.438	15003S	410	S
2.625	3.623	3.630	0.438	455003	450	S
2.625	3.623	3.630	0.469	415003	410	S
2.625	3.623	3.630	0.469	475003N	470	N

2.625	3.695	3.700	0.500	3813	640	H
2.625	3.696	3.700	0.500	41163T→	TFW-H	T
2.625	3.751	3.758	0.374	417343	410	S
2.625	3.813	3.818	0.415	200392	2000	S
2.625	3.876	3.881	0.468	415007	410	S

2.625	4.003	4.008	0.375	417082	410	S
2.625	4.064	4.069	0.960	712625	900	N
2.625	4.249	4.254	0.468	416278	410	S
2.625	4.437	4.441	0.437	418027	410	S
2.625	4.564	4.568	0.718	9773	740	N

2.625	4.564	4.568	0.718	9773R	740	N
--------------	-------	-------	-------	-------	-----	---

2.648"

2.648	3.812	3.817	0.500	486857	480	S
--------------	-------	-------	-------	--------	-----	---

2.667"

2.667	3.751	3.756	0.500	7780	40S	S
2.667	3.751	3.756	0.500	7780N	40S	S

2.677"

68mm

2.677 68	3.228 82	3.236 82.20	0.276 7	◆688207XX	350	S
2.677	3.228	3.236	0.276	710378	350	S
2.677 68	3.307 84	3.318 84.28	0.335 8.50	◆710234←	320	N
2.677	3.346	3.354	0.315	◆688508XX	350	S
2.677 68	3.386 85	3.398 85.20	0.315 8	226820	320	H

2.677 68	3.386 86	3.397 86.28	0.315 8	◆710334←	320	N
2.677 68	3.465 88	3.476 88.29	0.315 8	◆710446→	350	S
2.677	3.504	3.512	0.433	712511→	320	V
2.677 68	3.543 90	3.551 90.20	0.276 7	◆689007XX	320	S
2.677 68	3.543 90	3.556 90.32	0.394 10	◆689010XX	350	S

2.677 68	3.543 90	3.549 90.17	0.394 12	712108→	TFW-H	T
2.677 68	3.543 90	3.550 90.17	0.472 12	◆710440	470	S
2.677 68	3.740 95	3.748 95.20	0.394 10	◆689510XX	350	S
2.677	3.740	3.752	0.512	226840	#	V

Shaft	Bore	O.D.	Width	Part Number	Style	Matl
2.677 68	3.937 100	3.945 100.20	0.394 10	◆68X10010XX	350	S
2.677 68	3.937 100	3.948 100.28	0.512 13	◆68X10013XX	350	S
2.677	4.882	4.886	0.472	710275	400	N
2.687"						
2.687	3.500	3.507	0.374	455434	450	S
2.687	3.751	3.756	0.500	455151	450	S
2.687	3.876	3.876	0.250	365008	360	S
2.688"						
2.688	3.499	3.504	0.344	710091	2720	S
2.735"						
2.735	3.415	-	0.340	710039	#	U
2.748"						
2.748	3.543	3.555	0.591	4874N	#	N
2.748	3.876	3.886	0.552	4564V	#	V
2.748	3.881	3.885	0.464	710174	470	S
2.748	5.500	5.512	0.850	4876N→	#	N
2.750" 2 3/4"						
2.750	-	-	0.315	477872	470	S
2.750	-	6.200	0.700	6643S	520	S
2.750	3.125	3.130	0.187	310841	310	S
2.750	3.250	3.255	0.313	710038	#	U
2.750	3.481	3.486	0.500	480491	480	S
2.750	3.500	3.507	0.374	416664	410	S
2.750	3.500	3.507	0.374	455364	450	S
2.750	3.500	3.505	0.500	485364N	480	N
2.750	3.501	3.505	0.250	45827S	40S	S
2.750	3.538	3.543	0.437	457291	450	S
2.750	3.543	3.548	0.375	417484	410	S
2.750	3.543	3.548	0.375	417484N	410	N
2.750	3.543	3.550	0.438	415322	410	S
2.750	3.543	3.550	0.438	455322	450	S
2.750	3.543	3.550	0.438	455322N	450	N
2.750	3.543	3.550	0.438	455322V	450	V
2.750	3.543	3.550	0.438	475322N	470	N
2.750	3.623	3.630	0.374	415984	410	S
2.750	3.750	3.756	0.500	710010	#	U
2.750	3.751	3.756	0.250	46997S	40S	S
2.750	3.751	3.758	0.374	415004	410	S
2.750	3.751	3.758	0.374	417316	410	S
2.750	3.751	3.758	0.375	455004	450	S
2.750	3.751	3.756	0.500	475004H	470	H

Shaft	Bore	O.D.	Width	Part Number	Style	Matl
2.750	3.772	3.779	0.311	2222	2860	S
2.750	3.779	3.784	0.762	710395	Unitized	S
2.750	3.846	3.928	0.290	200942	2000E	S
2.750	3.876	3.883	0.374	475009N	470	N
2.750	3.876	3.883	0.374	475960	470	S
2.750	3.876	3.883	0.437	455009	450	S
2.750	3.876	3.883	0.438	415009	410	S
2.750	3.876	3.883	0.438	415009N	410	N
2.750	3.876	3.883	0.438	415960	410	S
2.750	3.937	3.942	0.500	476574N	470	N
2.750	4.003	4.008	0.375	416706	410	S
2.750	4.003	4.010	0.438	415272N	410	N
2.750	4.003	4.010	0.438	455272	450	S
2.750	4.125	4.132	0.563	476281	470	S
2.750	4.249	4.254	0.468	416282	410	S
2.750	4.249	4.254	0.500	476283N	470	N
2.750	4.999	5.004	0.468	55238	50S	S
2.750	5.500	5.506	0.500	417986N	410	N
2.750	5.501	5.506	1.266	3591	900	N
2.756" 70mm						
2.756 70	3.346 85	3.357 85.28	0.315 8	◆708508XX	350	S
2.756 70	3.425 87	3.436 87.27	0.335 8.50	◆1021←	320	V
2.756 70	3.425 87	3.436 87.27	0.335 8.50	◆1021V←	320	V
2.756 70	3.465 88	3.474 88.25	0.315 8	◆708808XX	480	S
2.756 70	3.465 88	3.476 88.29	0.472 12	◆227020←	320	H
2.756 70	3.465 88	3.474 88.25	0.472 12	◆708812XX	320	S
2.756 70	3.543 90	3.551 90.20	0.276 7	◆709007XX	320	S
2.756 70	3.543 90	3.556 90.32	0.394 10	◆227040←	350	H
2.756 70	3.543 90	3.556 90.32	0.394 10	◆709010XX	350	S
2.756 70	3.622 92	3.633 92.28	0.335 8.50	◆227045←	470	H
2.756 70	3.622 92	3.630 92.20	0.472 12	◆709212XX	320	S
2.756 70	3.740 95	3.751 95.28	0.394 10	◆709510XX	350	S
2.756 70	3.740 95	3.751 95.28	0.512 13	◆709513XX	350	S
2.756 70	3.937 100	3.945 100.20	0.394 10	◆70X10010XX	320	S
2.756 70	3.937 100	3.948 100.28	0.512 13	◆70X10013XX	350	S
2.756 70	4.000 105	4.009 105.30	0.469 7	40392	TFW-H	T
2.756 70	4.134 105	4.146 105.30	0.276 7	◆70X10507XX	320	S

Shaft	Bore	O.D.	Width	Part Number	Style	Matl
2.756	4.134	4.142	0.512	◆70X10513XX	350	S
70	105	105.20	13			
2.756	4.331	4.339	0.394	◆70X11010XX	350	S
70	110	110.20	10			
2.756	4.409	4.416	0.551	◆710339	250	S
70	112	112.17	14			

2.812" 2 13/16"

2.812	3.876	3.881	0.437	55010	410	S
2.812	4.003	4.008	0.468	475384	470	S
2.812	4.249	4.254	0.468	411348	410	S

2.813"

2.813	3.751	3.758	0.438	455005	450	S
2.813	3.875	3.882	0.438	417485	410	S

2.832"

2.832	3.622	3.633	0.374	710075←	320	V
--------------	-------	-------	-------	---------	-----	---

2.835" 72mm

2.835	3.465	3.474	0.276	◆1986	480	S
72	88	88.25	7			
2.835	3.465	3.474	0.276	◆1986S	480	S
72	88	88.25	7			
2.835	3.543	3.551	0.394	◆729010XX	350	S
72	90	90.20	10			
2.835	3.740	3.751	0.394	◆729510XX	350	S
72	95	95.28	10			
2.835	3.780	3.791	0.354	◆227235←	320	H
72	96	96.29	9			

2.835	3.937	3.945	0.394	◆72X10010XX	350	S
72	100	100.20	10			
2.835	3.937	3.949	0.472	◆72X10012XX↔	320	S
72	100	100.31	12			

2.843"

2.843	4.003	4.008	0.500	456837V	450	V
--------------	-------	-------	-------	---------	-----	---

2.844"

2.844	3.938	3.945	0.500	2081↔	410	S
--------------	-------	-------	-------	-------	-----	---

2.874"

2.874	3.386	3.397	0.197	239129	#	S
2.874	4.003	4.010	0.437	455011	450	S
2.874	4.174	4.181	0.374	2674	890	S

2.875" 2 7/8"

2.875	3.540	3.548	0.315	474230	470	S
2.875	3.623	3.630	0.374	415303	410	S
2.875	3.623	3.628	0.500	3783	650	H

Shaft	Bore	O.D.	Width	Part Number	Style	Matl
2.875	3.623	3.628	0.500	3783H	650	H
2.875	3.623	3.628	0.500	39802	TFW-H	T

2.875	3.750	3.755	0.500	41536	TPDW	T
2.875	3.750	3.755	0.500	41537	TPDW	T
2.875	3.750	3.757	0.500	455006	450	S
2.875	3.750	3.757	0.500	455006N	450	N
2.875	3.751	3.758	0.374	417344	410	S

2.875	3.751	3.756	0.375	487344V	480	V
2.875	3.875	3.882	0.413	9864S↔	570	S
2.875	3.876	3.883	0.374	417158	410	S
2.875	3.876	3.883	0.438	455355	450	S
2.875	4.003	4.008	0.250	43086S	40S	S

2.875	4.003	4.010	0.374	416921	410	S
2.875	4.125	4.130	0.375	417134	410	S
2.875	4.125	4.130	0.812	6780S	210	S
2.875	4.249	4.254	0.500	416285	410	S
2.875	4.335	4.340	0.437	455310	450	S

2.875	4.376	4.381	0.625	455556	450	S
2.875	4.499	4.504	0.468	455144	450	S

2.881"

2.881	3.429	3.436	0.291	4122	470	S
2.881	3.429	3.436	0.291	470547	470	S

2.913" 74mm

2.913	3.543	3.549	0.394	227409	320	H
2.913	3.858	3.869	0.472	◆227410→	320	H
74	98	98.27	12			

2.937" 2 15/16"

2.937	3.751	3.756	0.375	416956	410	S
2.937	3.876	3.881	0.375	417159	410	S
2.937	4.003	4.008	0.375	416654	410	S
2.937	4.003	4.010	0.438	455012	450	S
2.937	4.003	4.008	0.468	415012V	410	V

2.937	4.003	4.008	0.468	475012N	470	N
2.937	4.003	4.008	0.625	35012N	430	N
2.937	4.125	4.130	0.375	417486	410	S
2.937	4.250	4.254	0.468	416775	410	S
2.937	4.499	4.504	0.468	455356	450	S

2.937	4.939	4.944	1.250	712937	900	N
--------------	-------	-------	-------	--------	-----	---

2.938"

2.938	3.937	3.947	0.552	4563V	#	V
2.938	3.938	3.945	0.500	35949N	410	N
2.938	3.938	3.945	0.500	416500	410	S
2.938	3.938	3.945	0.500	476500N	470	N

Shaft	Bore	O.D.	Width	Part Number	Style	Matl	Shaft	Bore	O.D.	Width	Part Number	Style	Matl
2.953" 75mm							3.000" 3"						
2.953	3.268	3.425	0.157	◆710240	#	S	3.000	3.500	3.505	0.313	710028	#	U
75	83	87.00	4				3.000	3.686	3.702	0.523	7338N	560	N
2.953	3.543	3.551	0.315	◆759008XX	320	S	2.988	3.740	3.751	0.315	3698←	320	H
75	90	90.20	8				3.000	3.751	3.756	0.375	476023N	470	N
2.953	3.543	3.553	0.394	◆759010XX	320	S	3.000	3.751	-	0.375	9113N	470	V
75	90	90.25	10										
2.953	3.661	3.666	0.315	39804	TFW-H	T	3.000	3.751	3.758	0.437	417349	410	S
2.953	3.740	3.751	0.394	◆227530	350	S	3.000	3.751	3.758	0.500	415281N	410	N
75	95	95.28	10				3.000	3.876	3.883	0.437	417350	410	S
							3.000	3.876	3.883	0.437	455479	450	S
							3.000	3.876	3.883	0.437	455479V	450	V
2.953	3.740	3.751	0.394	◆716445	350	V							
75	95	95.28	10				3.000	3.876	3.887	0.500	355526	350	S
2.953	3.740	3.751	0.394	◆759510XX	350	S	3.000	3.936	3.941	0.500	455509	450	S
75	95	95.28	10				3.000	3.999	4.004	0.437	453182	450	S
2.953	3.937	3.948	0.394	◆227540	320	S	3.000	4.000	4.008	0.500	710011	#	U
75	100	100.28	10				3.000	4.000	4.004	0.656	710009	#	U
2.953	3.937	3.945	0.394	◆75X10010XX	320	S							
75	100	100.20	10				3.000	4.003	4.008	0.250	45013S	40S	S
2.953	3.937	3.948	0.472	◆75X10012XX	320	S	3.000	4.003	4.008	0.375	415995	410	S
75	100	100.27	12				3.000	4.003	4.008	0.375	415995A	410	A
							3.000	4.003	4.008	0.375	415995V	410	V
							3.000	4.003	4.010	0.437	415013	410	S
2.953	3.937	3.948	0.512	◆227550←	320	H							
75	100	100.28	13				3.000	4.003	4.010	0.437	415013N	410	N
2.953	3.937	3.944	0.512	◆710384	250	S	3.000	4.003	4.010	0.437	415836	410	S
75	100	100.18	13				3.000	4.003	4.010	0.437	455013	450	S
2.953	4.134	4.144	0.512	◆75X10513XX	320	S	3.000	4.003	4.010	0.469	455995N	450	N
75	105	105.27	13				3.000	4.125	4.132	0.437	417351	410	S
2.953	4.331	4.339	0.472	◆75X11012XX	320	S							
75	110	110.20	12				3.000	4.125	4.132	0.438	455154	450	S
2.953	4.409	4.416	0.394	710087	450	S	3.000	4.249	4.254	0.437	417487	410	S
							3.000	4.249	4.254	0.468	415086N	410	N
							3.000	4.249	4.256	0.468	455014	450	S
							3.000	4.249	4.256	0.468	455086	450	S
2.953	4.409	4.413	0.394	710376	#	S							
2.953	4.528	4.539	0.472	◆75X11512XX	350	S							
75	115	115.30	12				3.000	4.331	4.336	0.500	415962	410	S
2.953	4.724	4.729	0.320	200322	2000	S	3.000	4.375	4.382	0.625	417488	410	S
2.953	4.724	4.732	0.394	◆75X12010XX	320	S	3.000	4.500	4.507	0.469	455088	450	S
75	120	120.20	10				3.000	4.500	4.507	0.469	455088V	450	V
							3.000	4.501	4.508	0.433	415088	410	S
							3.000	4.501	4.506	0.468	477163N	470	N
							3.000	4.524	4.600	0.433	200133	2000E	S
							3.000	4.626	4.631	0.500	55548	50S	S
							3.000	4.751	4.756	0.625	416370	410	S
							3.000	4.875	4.881	0.625	455820	450	S
							3.000	4.938	4.943	0.740	3905	760	N
							3.000	4.999	5.007	0.438	455019	450	S
							3.000	5.500	5.506	0.531	3143N	740	N
							3.000	5.501	5.506	1.266	3592	900	N
							3.000	5.750	5.764	0.413	712000	#	N
							3.000	5.750	5.758	0.449	710008	740	N

Shaft	Bore	O.D.	Width	Part Number	Style	Matl
3.003"						
3.003	3.751	3.761	0.420	100495	Unitized	V
3.003	3.751	3.761	0.570	4810V→	#	V
3.003	3.751	3.761	0.570	714810←	#	V
3.003	4.937	4.948	0.662	4562V→	#	V
3.040"						
3.040	3.937	3.946	0.250	355669	350	S
3.040	6.412	6.418	0.658	710090	#	S
3.062" 3 1/16"						
3.062	4.230	4.350	0.390	200766	2000E	S
3.062	4.249	4.254	0.625	455015	450	S
3.062	4.999	5.004	0.468	455020	450	S
3.071" 78mm						
3.071	3.937	3.948	0.394	◆78X10010XX	350	S
	78	100	100.27	10		
3.071	4.134	4.142	0.394	◆78X10510XX	320	S
	78	105	105.20	10		
3.071	4.528	4.535	0.394	◆78X11510XX	320	S
	78	115	115.20	10		
3.110"						
3.110	-	5.750	0.375	7896S	510	S
3.110	3.898	3.913	0.378	712126←	TFW-H	T
3.125" 3 1/8"						
3.125	-	8.250	0.571	6649	520	S
3.125	3.750	3.768	0.437	712100←	TPDW	T
3.125	3.751	3.756	0.250	45825S	40S	S
3.125	3.936	3.943	0.512	2260	480	V
3.125	4.003	4.010	0.438	416404	410	S
3.125	4.003	4.008	0.500	457034	450	V
3.125	4.003	4.008	0.500	714470	480	V
3.125	4.125	4.130	0.375	417621	410	S
3.125	4.125	4.130	0.437	39809	TW-H	T
3.125	4.125	4.132	0.500	416011	410	S
3.125	4.125	4.130	0.562	415156N	410	N
3.125	4.126	4.130	0.437	39817	TFW-H	T
3.125	4.175	4.186	0.295	8976S	490	S
3.125	4.249	4.256	0.500	416288	410	S
3.125	4.249	4.254	0.625	415016N	410	N
3.125	4.376	4.383	0.500	417171	410	S
3.125	4.450	4.456	0.880	710080	#	S
3.125	4.500	4.507	0.500	417172	410	S
3.125	4.562	4.567	0.760	6644	50S	S

Shaft	Bore	O.D.	Width	Part Number	Style	Matl
3.125	4.562	4.567	1.198	5751	340	S
3.125	4.562	4.567	1.198	5751S	340	S
3.125	4.626	4.633	0.438	416297	410	S
3.125	4.751	4.756	0.500	416024	410	S
3.125	4.999	5.004	0.468	415021	410	S
3.125	5.251	5.256	0.468	415394	410	S
3.125	5.985	6.000	0.955	9600S	#	S
3.125	7.000	8.250	1.003	6481S	510	S
3.133"						
3.133	3.547	3.551	0.366	710106	#	S
3.150" 80mm						
3.150	3.780	3.791	0.354	◆228005←	320	V
	80	96	96.29	9		
3.150	3.858	3.869	0.394	◆228008←	320	X
	80	98	98.27	10		
3.150	3.937	3.948	0.394	◆228009←	320	H
	80	100	100.28	10		
3.150	3.937	3.948	0.394	◆228012	350	S
	80	100	100.28	10		
3.150	3.937	3.953	0.394	712111→	TFW-H	T
3.150	3.937	3.945	0.394	◆80X10010XX	350	S
	80	100	100.20	10		
3.150	3.937	3.948	0.512	◆228010←	320	H
	80	100	100.28	13		
3.150	3.937	3.948	0.512	◆228015→	320	H
	80	100	100.28	13		
3.150	3.937	3.953	0.512	712115→	TFW-H	T
3.150	3.937	3.953	0.512	712120→	TFW-H	T
3.150	3.937	3.953	0.512	712123→	TFW-H	T
3.150	4.134	4.142	0.394	◆80X10510XX	320	S
	80	105	105.20	10		
3.150	4.134	4.145	0.512	◆228020	320	S
	80	105	105.28	13		
3.150	4.134	4.144	0.512	◆80X10513XX	480	S
	80	105	105.27	13		
3.150	4.331	4.342	0.394	◆228030	350	S
	80	110	110.29	10		
3.150	4.331	4.342	0.394	◆80X11010XX	320	S
	80	110	110.28	10		
3.150	4.331	4.342	0.472	◆80X11012XX	350	S
	80	110	110.28	12		
3.150	4.724	4.732	0.394	◆80X12010XX	320	S
	80	120	120.20	10		
3.150	4.724	4.735	0.512	◆80X12013XX	320	S
	80	120	120.28	13		
3.180"						
3.180	4.180	4.185	0.750	3385	740	S

Shaft	Bore	O.D.	Width	Part Number	Style	Matl
3.187" 3 3/16"						
3.187	4.376	4.381	0.500	417490	410	S
3.187	4.501	4.508	0.500	455336	450	S
3.187	4.650	4.625	0.442	6358	470	S
3.187	4.999	5.004	0.468	455022	450	S
3.188"						
3.188	4.250	4.257	0.469	456105	450	S
3.209"						
3.209	3.535	-	0.091	710293	#	S
3.228" 82mm						
3.228	3.791	3.802	0.315	40375←	320	T
3.228	3.918	3.928	0.500	320691	320	V
3.228	4.134	4.146	0.512	1945←	320	H
3.228	4.134	4.146	0.512	◆228480←	320	H
	82	105	105.32	13		
3.228	4.134	4.144	0.512	◆82X10513XX	250	S
	82	105	105.25	13		
3.249"						
3.249	4.468	4.488	0.318	200870	2000E	S
3.250" 3 1/4"						
3.250	3.879	3.881	0.375	710180	470	V
3.250	4.003	4.008	0.375	417433	410	S
3.250	4.003	4.008	0.468	415563	410	S
3.250	4.003	4.008	0.468	55563	50S	T
3.250	4.125	4.130	0.562	455566	450	S
3.250	4.249	4.254	0.375	296470	290	F
3.250	4.249	4.254	0.375	416470N	410	N
3.250	4.249	4.256	0.375	476470	470	S
3.250	4.249	4.254	0.468	411275	410	V
3.250	4.249	4.256	0.469	415304	410	S
3.250	4.249	4.256	0.500	455018	450	S
3.250	4.249	4.256	0.500	455018N	450	N
3.250	4.249	4.282	0.650	4875N→	#	N
3.250	4.249	4.260	0.662	4543V→	#	V
3.250	4.250	4.255	0.500	710016	#	U
3.250	4.376	4.383	0.500	417181	410	S
3.250	4.500	4.600	0.315	7208S	2000E	S
3.250	4.500	4.506	0.375	418028	410	S
3.250	4.500	4.507	0.438	415137	410	S
3.250	4.500	4.507	0.438	455137	450	S
3.250	4.500	4.507	0.500	417352	410	S
3.250	4.500	4.507	0.718	6584S	740	S

Shaft	Bore	O.D.	Width	Part Number	Style	Matl
3.250	4.626	4.633	0.500	417353	410	S
3.250	4.723	4.729	0.468	415577	410	S
3.250	4.751	4.756	0.484	456305	450	S
3.250	4.999	5.004	0.468	415023	410	S
3.250	5.251	5.256	0.468	455328	450	S
3.250	5.500	5.506	0.500	417987N	410	N
3.253"						
3.253	4.249	4.260	0.635	100494	Unitized	V
3.253	5.500	5.511	0.630	4544V→	#	V
3.253	5.500	5.511	0.635	100557	Unitized	V
3.268" 83mm						
3.268	3.937	3.948	0.354	◆228250←	320	H
	83	100	100.28	9		
3.298"						
3.298	4.125	4.130	0.562	455500	450	S
3.298	4.125	4.130	0.562	475500	470	S
3.307" 84mm						
3.307	3.937	3.941	0.394	710294	470	S
3.307	4.094	4.105	0.433	◆228410←	320	V
	84	104	104.27	11		
3.307	4.646	4.650	0.276	710363←	#	V
3.312" 3 5/16"						
3.312	4.248	4.255	0.437	416292	410	S
3.312	4.376	4.381	0.500	417491	410	S
3.312	4.751	4.756	0.500	416313	410	S
3.312	4.999	5.004	0.468	455024	450	S
3.313"						
3.313	4.500	4.507	0.438	415085	410	S
3.313	4.500	4.507	0.438	456648	450	S
3.330"						
3.330	4.125	4.130	0.562	477055	470	S
3.330	4.125	4.130	0.562	477055S	47	S
3.330	5.045	5.050	0.800	710088	#	S
3.346" 85mm						
3.346	4.134	4.145	0.394	◆716102←	320	H
	85	105	105.28	10		
3.346	4.134	4.145	0.394	◆85X10510XX	320	S
	85	105	105.28	10		
3.346	4.134	4.145	0.512	◆85X10513XX	320	S
	85	105	105.28	13		
3.346	4.331	4.339	0.394	◆85X11010XX	350	S
	85	110	110.20	10		

Shaft	Bore	O.D.	Width	Part Number	Style	Matl
3.346 85	4.331 110	4.342 110.29	0.472 12	◆228520	350	S
3.346 85	4.331 110	4.342 110.28	0.472 12	◆85X11012XX	350	S
3.346	4.449	4.457	0.413	710330	#	N
3.346 85	4.528 115	4.528 115.00	0.512 13	◆85X11513XX	350	S
3.346 85	4.724 120	4.735 120.28	0.472 12	◆85X12012XX	320	S
3.346 85	4.921 125	4.929 125.20	0.472 12	◆85X12512XX	320	S
3.346 85	5.118 130	5.124 130.15	0.500 12.70	◆85X13013XX	480	S

3.374"

3.374	4.375	4.382	0.374	412473	410	S
--------------	-------	-------	-------	--------	-----	---

3.375"

3 3/8"

3.375	3.948	3.955	0.375	5128N	320	N
3.375	3.948	3.955	0.375	710077	320	S
3.375	4.125	4.130	0.375	415442	410	S
3.375	4.249	4.256	0.500	416294	410	S
3.375	4.249	4.256	0.500	416294V	410	V

3.375	4.376	4.383	0.500	415894	410	S
3.375	4.376	4.381	0.625	415164N	410	N
3.375	4.499	4.504	0.468	455165	450	S
3.375	4.500	4.507	0.500	417191	410	S
3.375	4.501	4.506	0.468	456585	450	S

3.375	4.626	4.633	0.500	417354	410	S
3.375	4.688	4.693	0.500	55249	450	S
3.375	4.751	4.756	0.500	416321	410	S
3.375	4.999	4.504	0.468	415025	410	S
3.375	5.251	5.256	0.468	416327	410	S

3.386"

86mm

3.386 86	4.055 103	4.066 103.28	0.394 10	◆710235←	320	V
3.386 86	4.094 104	4.109 104.37	0.433 11	◆710232	320	V

3.425"

87mm

3.425 87	3.937 100	3.948 100.28	0.315 8	◆228700←	320	H
--------------------	--------------	-----------------	------------	----------	-----	---

3.437"

3 7/16"

3.437	4.249	4.254	0.375	418029	410	S
3.437	4.501	4.506	0.375	417492	410	S
3.437	4.501	4.506	0.625	55419	50S	S
3.437	4.626	4.631	0.500	417493	410	S

Shaft	Bore	O.D.	Width	Part Number	Style	Matl
3.437	4.876	4.881	0.500	417494	410	S
3.437	4.999	5.004	0.468	455026	450	S
3.437	5.250	5.256	0.468	455471	450	S

3.438"

3.438	4.249	4.256	0.375	455499	450	S
3.438	4.756	4.764	0.563	455858	450	S

3.465"

88mm

3.465 88	4.173 106	4.184 106.27	0.335 8.50	◆710188←	320	V
3.465 88	4.252 108	4.263 108.28	0.433 11	◆3772←	350	H
3.465 88	4.331 110	4.342 110.28	0.472 12	◆88X11012XX	350	S

3.468"

3.468	4.626	4.631	0.625	2055	470	S
--------------	-------	-------	-------	------	-----	---

3.500"

3 1/2"

3.500	4.000	4.005	0.313	710029	#	U
3.500	4.125	4.130	0.250	446927	440	S
3.500	4.125	4.130	0.250	45525S	40S	S
3.500	4.125	4.130	0.312	710030	#	U
3.500	4.331	4.346	0.472	712116→	TFW-H	T

3.500	4.375	4.381	0.562	415899N	410	N
3.500	4.376	4.383	0.500	416624	410	S
3.500	4.376	4.383	0.500	416624N	410	N
3.500	4.437	4.437	0.437	5965	80S	S
3.500	4.450	4.455	0.525	9339S	2780	S

3.500	4.499	4.508	0.250	345146	340	S
3.500	4.499	4.504	0.468	415146	410	S
3.500	4.499	4.504	0.468	455146	450	S
3.500	4.500	4.506	0.500	710015	#	U
3.500	4.501	4.506	0.438	415991	410	S

3.500	4.501	4.506	0.438	415991N	410	N
3.500	4.501	4.506	0.468	712750	410	V
3.500	4.501	4.506	0.875	15305S	10S	S
3.500	4.626	4.633	0.500	417196	410	S
3.500	4.750	4.758	0.500	415437	410	S

3.500	4.750	4.758	0.500	455173	450	S
3.500	4.750	4.758	0.500	476424N	470	N
3.500	4.751	4.756	0.500	455437N	450	N
3.500	4.875	4.881	0.500	417198	410	S
3.500	4.999	5.004	0.468	415027H	410	H

3.500	4.999	5.004	0.468	415027N	410	N
3.500	4.999	5.004	0.468	455027	450	S
3.500	4.999	5.004	0.468	455027N	450	N
3.500	4.999	5.004	0.468	485027	480	N

Shaft	Bore	O.D.	Width	Part Number	Style	Matl
3.500	5.126	5.131	0.500	417495	410	S
3.500	5.126	5.131	0.625	715319	470	N
3.500	5.250	5.258	0.562	6612S	#	S
3.500	5.251	5.256	0.468	415559	410	S
3.500	5.500	5.505	0.500	417496	410	S
3.500	5.751	5.756	0.562	455396	450	S

3.504" 89mm

3.504	4.134	4.145	0.394	◆710189←	470	V
89	105	105.28	10			
3.504	4.291	4.299	0.354	229004←	320	H

3.543" 90mm

3.543	4.094	4.105	0.433	◆710237←	320	V
90	104	104.27	11			
3.543	4.252	4.261	0.394	710219←	320	N
3.543	4.331	4.342	0.354	◆229005←	320	V
90	110	110.29	9			
3.543	4.331	4.342	0.354	◆229006←	320	H
90	110	110.29	9			
3.543	4.331	4.342	0.354	◆229010←	320	H
90	110	110.29	9			

3.543	4.331	4.346	0.472	712124→	TFW-H	T
3.543	4.331	4.339	0.472	◆90X11012XX	350	S
90	110	110.20	12			
3.543	4.528	4.535	0.472	◆90X11512XX	320	S
90	115	115.20	12			
3.543	4.724	4.735	0.472	◆90X12012XX	320	S
90	120	120.28	12			
3.543	4.921	4.949	0.276	◆90X12507XX	320	S
90	125	125.70	7			

3.543	4.921	4.933	0.512	◆90X12513XX	320	S
90	125	125.30	13			
3.543	5.709	5.717	0.551	◆90X14514XX	320	S
90	145	145.20	14			
3.543	6.215	6.220	0.562	39865	#	T

3.562" 3 9/16"

3.562	4.499	4.504	0.468	415498	410	S
3.562	4.625	4.631	0.500	415711	410	S
3.562	4.751	4.756	0.500	417497	410	S
3.562	4.755	4.761	0.550	9584	740	S
3.562	4.876	4.881	0.500	417498	410	S

3.562	4.999	5.004	0.468	55028	50S	S
-------	-------	-------	-------	-------	-----	---

3.583" 91mm

3.583	4.331	4.342	0.335	◆229210←	320	V
91	110	110.29	8.50			
3.583	4.370	4.381	0.394	◆710056←	470	V
91	111	111.28	10			

Shaft	Bore	O.D.	Width	Part Number	Style	Matl
-------	------	------	-------	-------------	-------	------

3.620"

3.620	4.625	4.630	0.400	39882	TFW-H	T
-------	-------	-------	-------	-------	-------	---

3.622" 92mm

3.622	4.724	4.734	0.512	◆92X12013XX	350	S
92	120	120.24	13			

3.625" 3 5/8"

3.625	4.240	4.251	0.390	3909←	350	V
3.625	4.375	4.382	0.374	456744N	450	N
3.625	4.376	4.381	0.375	417698	410	S
3.625	4.376	4.381	0.375	417698S	41	S
3.625	4.499	4.504	0.468	415389	410	S

3.625	4.499	4.504	0.468	415389N	410	N
3.625	4.624	4.630	0.500	487397V→	480	V
3.625	4.625	4.631	0.437	416332	410	S
3.625	4.626	4.633	0.500	416047	410	S
3.625	4.695	4.810	0.395	200603	2000E	S

3.625	4.750	4.758	0.500	415937	410	S
3.625	4.751	4.756	0.500	39703	TFW-H	T
3.625	4.751	4.756	0.500	39813	TW-H	T
3.625	4.839	4.844	0.500	55353	50S	S
3.625	4.875	4.883	0.500	417355	410	S

3.625	4.875	4.883	0.500	485497	480	S
3.625	4.999	5.007	0.500	416125	410	S
3.625	5.251	5.256	0.437	417499	410	S
3.625	5.375	5.381	0.500	415832	410	S
3.625	5.501	5.506	0.500	417500	410	S

3.625	5.751	5.756	0.562	415436	410	S
-------	-------	-------	-------	--------	-----	---

3.661" 93mm

3.661	4.488	4.500	0.512	◆710288←	320	S
93	114	114.30	13			
3.661	6.063	6.071	0.315	◆710266	#	S
93	154	154.20	8			

3.687" 3 11/16"

3.687	4.501	4.506	0.500	416919	410	S
3.687	4.501	4.506	0.500	416919N	410	N
3.687	4.750	4.756	0.500	417501	410	S
3.687	4.999	5.004	0.468	55030	50S	S
3.687	5.250	5.256	0.468	416670	410	S

3.687	5.501	5.506	0.500	417502	410	S
-------	-------	-------	-------	--------	-----	---

Shaft	Bore	O.D.	Width	Part Number	Style	Matl
3.736"						
3.736	4.724	4.740	0.512	712119→	TFW-H	T
3.740" 95mm						
3.740	4.331	4.339	0.394	◆95X11010XX	320	S
95	110	110.20	10			
3.740	4.331	4.342	0.433	◆717005←	320	S
95	110	110.29	11			
3.740	4.449	4.453	0.394	◆710352	470	V
95	113	113.10	10			
3.740	4.525	4.536	0.492	4359V←	320	V
3.740	4.528	4.537	0.394	717006	450	S
3.740	4.528	4.539	0.472	◆95X11512XX	350	S
95	115	115.28	12			
3.740	4.646	4.657	0.394	◆710060←	320	H
95	118	118.29	10			
3.740	4.724	4.735	0.472	◆95X12012XX	350	S
95	120	120.28	12			
3.740	4.921	4.932	0.472	◆95X12512XX	350	S
95	125	125.28	12			
3.740	5.118	5.129	0.472	229520	350	S
3.740	5.118	5.129	0.472	◆95X13012XX	350	S
95	130	130.28	12			
3.740	6.772	6.775	1.102	39926	TW-H	T
3.750" 3 3/4"						
3.750	4.375	4.381	0.313	710035	#	U
3.750	4.500	4.507	0.468	415983	410	S
3.750	4.500	4.507	0.468	415983N	410	N
3.750	4.500	4.507	0.468	415983V	410	V
3.750	4.500	4.506	0.468	713750	690	V
3.750	4.501	4.506	0.362	2377	350	V
3.750	4.626	4.633	0.500	416041	410	S
3.750	4.750	4.756	0.500	3893V	450	V
3.750	4.750	4.756	0.500	39608	TDW-H	T
3.750	4.750	4.756	0.500	39705	TFW-H	T
3.750	4.750	4.756	0.500	39837	TW-H	T
3.750	4.750	4.758	0.500	415379	410	S
3.750	4.750	4.758	0.500	455379	450	S
3.750	4.750	4.758	0.500	455379V	450	V
3.750	4.751	4.756	0.500	2218	470	H
3.750	4.751	4.756	0.875	15379S	10S	S
3.750	4.875	4.883	0.500	417205	410	S
3.750	4.999	5.004	0.250	45031S	40S	S
3.750	4.999	5.004	0.468	455031	450	S
3.750	4.999	5.007	0.500	416339	410	S
3.750	5.251	5.256	0.468	415150	410	S
3.750	5.376	5.381	0.500	416127	410	S
3.750	5.501	5.506	0.500	417503	410	S

Shaft	Bore	O.D.	Width	Part Number	Style	Matl
3.780"						
3.780	4.567	4.577	0.354	710262	320	V
3.780	4.606	4.617	0.472	710205	320	V
3.797"						
3.797	4.501	4.506	0.250	8370S	40S	S
3.812" 3 13/16"						
3.812	4.876	4.881	0.500	417504	410	S
3.812	4.999	5.004	0.468	455032	450	S
3.812	5.251	5.256	0.468	455189	450	S
3.858" 98mm						
3.858	4.525	4.540	0.620	100085←	#	T
3.858	4.724	4.732	0.512	◆98X12013XX	350	S
98	120	120.20	13			
3.875" 3 7/8"						
3.875	4.751	4.756	0.375	417210	410	S
3.875	4.875	4.883	0.500	417211	410	S
3.875	4.999	5.004	0.468	455033	450	S
3.875	4.999	5.007	0.500	416345	410	S
3.875	5.125	5.133	0.500	415697	410	S
3.875	5.125	5.133	0.500	455547	450	S
3.875	5.126	5.131	0.625	55547	450	S
3.875	5.250	5.258	0.500	417366	410	S
3.875	5.375	5.383	0.438	455958	450	S
3.875	5.375	5.383	0.438	455958S	450	S
3.875	5.375	5.383	0.438	455958S	450	S
3.875	5.376	5.381	0.500	415958	410	S
3.875	5.501	5.506	0.500	417505	410	S
3.875	5.751	5.756	0.562	416043	410	S
3.880"						
3.880	5.690	5.695	0.500	55581	450	S
3.934"						
3.934	5.905	5.911	0.500	476517	470	S
3.937" 100mm						
3.937	4.488	4.496	0.472	◆710410	470	S
100	114	114.20	12			
3.937	4.724	4.736	0.394	◆10X012010XX	350	S
100	120	120.30	10			
3.937	4.724	4.735	0.433	◆231004	320	H
100	120	120.27	11			

Shaft	Bore	O.D.	Width	Part Number	Style	Matl	Shaft	Bore	O.D.	Width	Part Number	Style	Matl	
3.937	4.724	4.734	0.433	712105←	TW	T	4.000	5.125	5.133	0.500	455188	450	S	
3.937	4.724	4.735	0.472	◆10X012012XX	350	S								
100	120	120.28	12											
3.937	4.724	4.730	0.472	◆231002	350	S	4.000	5.250	5.258	0.500	417357	410	S	
100	120	120.13	12				4.000	5.251	5.256	0.468	415192N	410	N	
3.937	4.876	4.881	0.500	417967	410	S	4.000	5.251	5.256	0.468	455192	450	S	
3.937	4.882	4.890	0.512	710290	320	V	4.000	5.375	5.383	0.500	416130	410	S	
3.937	4.921	4.932	0.472	◆10X012512XX	350	S	4.000	5.501	5.506	0.562	415036	410	S	
100	125	125.28	12											
3.937	4.921	4.935	0.472	◆231003	350	S	4.000	5.625	5.633	0.437	455513	450	S	
100	125	125.35	12				4.000	5.626	5.632	0.375	417507	410	S	
3.937	4.999	5.004	0.468	415034	410	S	4.000	5.751	5.756	0.562	415041	410	S	
3.937	4.999	5.004	0.468	455034	450	S	4.000	5.999	6.005	0.500	417509	410	S	
3.937	5.118	5.129	0.472	◆10X013012XX	350	S	4.000	6.250	6.256	0.500	417223	410	S	
100	130	130.28	12											
3.937	5.251	5.256	0.468	455191	450	S	4.016"						102mm	
3.937	5.315	5.329	0.394	◆710351←	320	H	4.016	5.118	5.129	0.512	◆10X213013XX	350	S	
100	135	135.36	10				102	130	130.28	13				
3.937	5.315	5.323	0.591	710391←	940	H	4.050"							
3.937	5.371	5.377	0.906	6270	210	S	4.050	5.501	5.506	0.671	6864S	450	S	
3.937	5.376	5.384	0.500	415263	410	S								
3.937	5.709	5.713	1.024	710278	#	N	4.062"							
3.938"							4.062	5.501	5.506	0.562	455037	450	S	
3.938	4.876	4.884	0.438	455186	450	S	4.062	6.191	6.197	0.625	57831	50S	S	
3.976"							101mm							
3.976	4.488	4.492	0.394	◆710371	250	S	4.125"						4 1/8"	
101	114	114.10	10				4.125	4.998	5.006	0.437	455134	450	S	
4.000"							4"							
4.000	4.562	4.568	0.375	335924N	330	N	4.125	4.999	5.004	0.468	6565N	410	N	
4.000	4.625	4.631	0.313	710036	#	U	4.125	4.999	5.005	1.037	37921	TPDW	T	
4.000	4.750	4.756	0.313	710031	#	U	4.125	5.126	5.132	0.500	417511	410	S	
4.000	4.750	4.756	0.562	457294	450	S	4.125	5.251	5.256	0.468	415142	410	S	
4.000	4.876	4.881	0.250	45187S	40S	S								
4.000	4.876	4.881	0.625	415187	410	S	4.125	5.501	5.506	0.500	417512	410	S	
4.000	4.998	5.006	0.468	327215	320	S	4.125	5.751	5.756	0.562	415043	410	S	
4.000	4.998	5.006	0.468	415035	410	S	4.125	6.000	6.007	0.625	455203	450	S	
4.000	4.998	5.006	0.468	455035	450	S	4.125	6.250	6.256	0.562	455056	450	S	
4.000	4.998	5.006	0.468	455035N	450	N	4.134"						105mm	
4.000	4.998	5.006	0.500	710022	450	H	4.134	4.724	4.732	0.433	231052	320	H	
4.000	4.999	5.008	0.312	345035	340	S	4.134	4.921	4.932	0.512	◆10X512513XX	320	S	
4.000	4.999	5.004	0.375	475845	470	S	105	125	125.28	13				
4.000	4.999	5.004	0.469	714713↔	960	V	4.134	5.118	5.124	0.433	712107→	TFW-H	T	
4.000	4.999	5.005	0.500	37939	TPDW	T	4.134	5.118	5.129	0.472	◆10X513012XX	350	S	
4.000	4.999	5.007	0.500	415953	410	S	105	130	130.28	12				
4.000	5.000	5.005	0.312	456967V	450	V	4.134	5.118	5.128	0.472	712004←	320	V	
4.000	5.000	5.005	0.500	39723	TFW-H	T	4.134	5.315	5.323	0.571	710349	#	V	
4.000	5.125	5.133	0.500	417356	410	S	4.134	5.512	5.523	0.472	◆10X514012XX	350	S	
							105	140	140.28	12				
4.166"							4.166"							
4.166	5.501	5.509	0.610	9128S	450	S								

Shaft	Bore	O.D.	Width	Part Number	Style	Matl
4.173" 106mm						
4.173	4.843	4.846	0.433	710295	470	S
4.173	4.961	4.975	0.472	◆710366←	320	H
106	126	126.37	12			
4.187" 4 3/16"						
4.187	4.999	5.004	0.468	415295	410	S
4.187	5.251	5.256	0.468	455194	450	S
4.187	5.501	5.506	0.500	417513	410	S
4.187	5.751	5.756	0.500	417514	410	S
4.187	6.000	6.007	0.500	417515	410	S
4.187	6.250	6.256	0.500	417516	410	S
4.250" 4 1/4"						
4.250	5.250	5.258	0.500	416556	410	S
4.250	5.251	5.259	0.251	47150S	40S	S
4.250	5.251	5.256	0.375	472157	470	S
4.250	5.251	5.256	0.468	455195	450	S
4.250	5.251	5.256	0.468	485195H	480	H
4.250	5.375	5.383	0.500	415196	410	S
4.250	5.500	5.508	0.500	416891	410	S
4.250	5.625	5.633	0.500	416135	410	S
4.250	5.751	5.756	0.562	415045	410	S
4.250	5.999	6.005	0.500	416137	410	S
4.250	6.126	6.133	0.500	417518	410	S
4.250	6.250	6.256	0.562	415058	410	S
4.312" 4 5/16"						
4.312	5.376	5.381	0.500	456141	450	S
4.312	5.501	5.506	0.562	455197	450	S
4.312	5.501	5.506	0.562	455197N	450	N
4.312	5.751	5.756	0.500	417520	410	S
4.312	5.999	6.005	0.500	416144	410	S
4.312	6.250	6.256	0.500	417238	410	S
4.331" 110mm						
4.331	5.118	5.132	0.394	◆2261←	470	V
110	130	130.35	10			
4.331	5.118	5.129	0.472	◆11X013012XX	350	S
110	130	130.28	12			
4.331	5.118	5.134	0.512	712112←	TW	T
4.331	5.315	5.327	0.512	◆11X013513XX	320	S
110	135	135.30	13			
4.331	5.512	5.523	0.472	◆11X014012XX	320	S
110	140	140.28	12			
4.331	5.512	5.521	0.512	◆11X014013XX	450	S
110	140	140.23	13			
4.331	5.709	5.720	0.512	◆11X014513XX	350	S
110	145	145.30	13			

Shaft	Bore	O.D.	Width	Part Number	Style	Matl
4.331	5.906	5.917	0.591	◆11X015015XX	350	S
110	150	150.28	15			
4.331	6.693	6.700	0.500	476518	470	S
4.375" 4 3/8"						
4.375	5.373	5.500	0.570	7354N	80S	N
4.375	5.375	5.425	0.500	4291V	#	V
4.375	5.376	5.381	0.500	415425	410	S
4.375	5.500	5.506	0.500	416380	410	S
4.375	5.500	5.508	0.563	455198	450	S
4.375	5.501	5.506	0.500	39849	TFWH	T
4.375	5.626	5.631	0.500	416147	410	S
4.375	5.751	5.756	0.562	415047	410	S
4.375	5.999	6.005	0.500	416149	410	S
4.375	6.064	6.071	0.625	6635S	450	S
4.375	6.125	6.131	0.500	417522	410	S
4.375	6.250	6.256	0.562	415060	410	S
4.375	6.250	6.256	0.562	455060	450	S
4.409" 112mm						
4.409	5.512	5.524	0.512	◆11X2140013XX	350	S
112	140	140.32	13			
4.437"						
4.437	5.500	5.506	0.500	417295	410	S
4.437	5.501	5.509	0.563	457295	250	S
4.437	5.751	5.756	0.500	417525	410	S
4.437	5.999	6.007	0.500	417526	410	S
4.488" 114mm						
4.488	5.512	5.523	0.512	◆11X414013XX	350	S
114	140	140.28	13			
4.500" 4 1/2"						
4.500	5.251	5.259	0.437	327303	320	S
4.500	5.375	5.383	0.438	417530	410	S
4.500	5.500	5.514	0.500	355200	350	S
4.500	5.500	5.508	0.500	416888	410	S
4.500	5.500	5.508	0.500	455200	450	S
4.500	5.500	5.508	0.500	455200N	450	N
4.500	5.625	5.631	0.500	416153	410	S
4.500	5.625	5.631	0.500	456153	450	S
4.500	5.750	5.758	0.500	416892	410	S
4.500	5.876	5.881	0.500	417531	410	S
4.500	6.000	6.014	0.500	416154	410	S
4.500	6.125	6.131	0.562	416070	410	S
4.500	6.250	6.256	0.500	415351	410	S
4.500	6.374	6.382	0.500	417532	410	S

Shaft	Bore	O.D.	Width	Part Number	Style	Matl
4.528"			115mm			
4.528	5.315	5.329	0.394	◆710258←	320	V
115	135	135.36	10			
4.528	5.512	5.523	0.472	◆11X514012XX	350	S
115	140	140.28	12			
4.528	5.709	5.720	0.512	◆11X514513XX	350	S
115	145	145.30	13			
4.528	5.709	5.717	0.551	◆11X514514XX	320	S
115	145	145.20	14			
4.528	5.906	5.917	0.472	◆11X515012XX	350	S
115	150	150.28	12			
4.528	6.142	6.146	0.610	◆710372	#	S
115	156	156.10	15.50			
4.562"			4 9/16"			
4.562	5.751	5.756	0.500	417533	410	S
4.562	5.999	6.007	0.500	417534	410	S
4.562	6.250	6.256	0.500	457585	450	S
4.625"			4 5/8"			
4.625	5.500	5.506	0.562	456641	450	H
4.625	5.625	5.631	0.500	416156	410	S
4.625	5.751	5.756	0.562	415371	410	S
4.625	5.875	5.881	0.625	455685	450	S
4.625	5.999	6.007	0.500	416158	410	S
4.625	6.186	6.192	1.250	2505	890	S
4.625	6.250	6.256	0.562	415064	410	S
4.625	6.622	6.629	1.093	7700S	210	S
4.646"						
4.646	5.751	5.756	0.500	39952	TFWH	T
4.646	6.811	6.843	1.102	710089	#	S
4.687"			4 11/16"			
4.687	5.751	5.756	0.500	415284	410	S
4.687	5.751	5.756	0.562	455378H	450	H
4.687	5.751	5.756	0.750	6329S	70S	S
4.687	5.999	6.007	0.500	417535	410	S
4.687	6.002	6.007	0.250	45637S	40S	S
4.687	6.250	6.256	0.500	417536	410	S
4.687	6.374	6.382	0.500	417537	410	S
4.720"						
4.720	6.312	6.318	0.473	457734	450	S
4.724"			120mm			
4.724	5.512	5.520	0.413	710084	470	S

Shaft	Bore	O.D.	Width	Part Number	Style	Matl
4.724	5.512	5.520	0.472	◆717004	480	S
120	140	140.21	12			
4.724	5.512	5.523	0.512	◆12X014013XX	350	S
120	140	140.28	13			
4.724	5.512	5.524	0.512	712003←	320	V
4.724	5.512	5.520	0.512	712106	320	T
4.724	5.709	5.720	0.472	◆12X014512XX	350	S
120	145	145.28	12			
4.724	5.709	5.720	0.472	231204	350	S
4.724	5.906	5.917	0.472	◆12X015012XX	350	S
120	150	150.28	12			
4.724	6.299	6.310	0.472	◆12X016012XX	350	S
120	160	160.28	12			
4.750"			4 3/4"			
4.750	5.375	5.381	0.313	710037	#	A
4.750	5.750	5.758	0.500	415138	410	S
4.750	5.751	5.756	0.500	714750	480	V
4.750	5.876	5.881	0.500	417538	410	S
4.750	5.999	6.007	0.625	415213N	410	N
4.750	6.000	6.006	0.562	39732	TFWH	T
4.750	6.000	6.006	0.562	39825	TFWH	T
4.750	6.000	6.006	0.562	39827	TDWH	T
4.750	6.001	6.009	0.500	417247	410	S
4.750	6.002	6.092	0.285	200642	2000	S
4.750	6.125	6.131	0.500	417252	410	S
4.750	6.186	6.192	1.250	3100	890	S
4.750	6.251	6.259	0.563	415066	410	S
4.750	6.618	6.625	1.141	6663S	890	S
4.812"			4 13/16"			
4.812	5.543	5.551	0.472	712449←	320	V
4.812	5.544	5.552	0.535	3341	1000	H
4.812	5.751	5.756	0.562	455251H	450	H
4.812	5.999	6.007	0.500	416163	410	S
4.812	6.250	6.256	0.500	456890	450	S
4.820"						
4.820	5.751	5.756	0.750	75251S	70S	S
4.835"						
4.835	5.749	5.756	0.375	39954	TDWH	T
4.874"						
4.874	6.001	6.009	0.500	455091	450	S
4.874	6.250	6.258	0.500	455068	450	S
4.875"			4 7/8"			
4.875	5.999	6.007	0.500	416167	410	S
4.875	6.125	6.131	0.500	417267	410	S

Shaft	Bore	O.D.	Width	Part Number	Style	Matl
4.875	6.250	6.256	0.500	417269	410	S
4.875	6.375	6.625	0.500	7866S	750	S
4.882"						
4.882	5.748	5.752	0.551	710405	470	S
4.882	6.693	-	0.571	◆710381	#	S
124	170	-	14.50			
4.921" 125mm						
4.921	5.906	5.917	0.472	◆12X515012XX	320	S
125	150	150.28	12			
4.921	5.906	5.920	0.472	◆231250	350	S
125	150	150.37	12			
4.921	6.102	6.110	0.472	◆12X515512XX	320	S
125	155	155.20	12			
4.921	6.299	6.310	0.472	◆12X516012XX	350	S
125	160	160.28	12			
4.921	6.693	6.701	0.591	◆12X517015XX	320	S
125	170	170.20	15			
4.937"						
4.937	5.999	6.007	0.500	417539	410	S
4.937	6.250	6.256	0.500	417273	410	S
4.937	6.374	6.382	0.500	417540	410	S
4.993" 5"						
4.993	6.000	6.006	0.413	39881	TFW-H	T
5.000" 5"						
5.000	5.750	5.756	0.313	710032	#	U
5.000	5.751	5.756	0.500	3492V	480	V
5.000	5.999	6.006	0.413	39880	940	T
5.000	6.000	6.006	0.413	39801	TFW-H	T
5.000	6.000	6.016	0.591	712109←	TFW-H	T
5.000	6.001	6.009	0.500	415725	410	S
5.000	6.125	6.131	0.500	39958	TFW-H	T
5.000	6.126	6.131	0.562	417584	410	S
5.000	6.250	6.256	0.250	204509	2040	S
5.000	6.250	6.258	0.500	455070	450	S
5.000	6.250	6.256	0.500	456865N	450	N
5.000	6.251	6.250	0.500	416865	410	S
5.000	6.375	6.381	0.500	417278	410	S
5.000	6.499	6.507	0.500	417541	410	S
5.000	6.622	6.629	0.906	8126S	890	S
5.000	6.749	6.757	0.500	417542	410	S
5.000	6.874	6.882	0.500	417543	410	S
5.000	6.877	6.884	0.625	415897	410	S
5.000	7.000	7.007	0.500	417544	410	S
5.000	7.500	7.507	0.500	417545	410	S

Shaft	Bore	O.D.	Width	Part Number	Style	Matl
5.039" 128mm						
5.039	5.748	5.752	0.394	710411	470	S
5.039	5.906	5.917	0.591	◆12X815015XX	350	S
128	150	150.28	15			
5.062"						
5.062	6.374	6.382	0.625	455290	450	S
5.062	6.994	7.004	1.312	7378	50S	S
5.118" 130mm						
5.118	5.906	5.909	0.394	◆13X015010XX	470	S
130	150	150.10	10			
5.118	5.906	5.914	0.394	◆710380	470	S
130	150	150.22	10			
5.118	5.906	5.921	0.512	712114←	TFW-H	T
5.118	5.906	5.923	0.571	39806→	TFW-H	T
5.118	5.906	5.923	0.583	39805	TFW-H	T
5.118	6.299	6.310	0.472	◆13X016012XX	350	S
130	160	160.28	12			
5.118	6.299	6.307	0.591	◆13X016015XX	320	S
130	160	160.20	15			
5.118	6.693	6.705	0.472	◆13X017012XX	350	S
130	170	170.30	12			
5.118	6.693	6.704	0.591	◆13X017015XX	350	S
130	170	170.28	15			
5.125" 5 1/8"						
5.125	6.125	6.131	0.500	416557	410	S
5.125	6.125	6.131	0.500	456557	450	V
5.125	6.250	6.256	0.500	417258	410	S
5.125	6.374	6.382	0.500	417546	410	S
5.125	6.499	6.507	0.500	417547	410	S
5.187" 5 3/16"						
5.187	6.499	6.507	0.500	417548	410	S
5.187	6.500	6.507	0.625	455956H	450	H
5.250" 5 1/4"						
5.250	-	-	0.500	357262H←	350	S
5.250	6.250	6.256	0.250	447060	440	S
5.250	6.250	6.264	0.251	345448	340	S
5.250	6.250	6.256	0.500	417262	410	S
5.250	6.250	6.256	0.500	417262V	410	V
5.250	6.250	6.256	0.562	455448	450	S
5.250	6.375	6.381	0.500	417358	410	S
5.250	6.500	6.507	0.562	415645	410	S
5.250	6.500	6.508	0.625	455104	450	S
5.250	6.625	6.632	0.562	417359	410	S
5.250	6.750	6.757	0.500	417549	410	S

Shaft	Bore	O.D.	Width	Part Number	Style	Matl
5.312"						
5.312	6.500	6.507	0.500	417550	410	S
5.315" 135mm						
5.315	6.299	6.314	0.512	◆13X516013XX	350	S
	135	160	160.38	13		
5.375" 5 3/8"						
5.375	6.374	6.380	0.500	417551	410	S
5.375	6.499	6.507	0.562	455576	450	S
5.375	6.624	6.632	0.562	415938	410	S
5.375	6.749	6.757	0.500	417554	410	S
5.375	6.875	6.882	1.000	3292	890	S
5.375	7.874	7.881	0.750	416112	410	S
5.428"						
5.428	6.500	6.505	0.420	710425	2300	S
5.433" 138mm						
5.433	5.984	5.988	0.472	◆13X815212XX	470	S
	138	152	152.10	12		
5.433	5.984	5.992	0.472	◆710368	470	S
	138	152	152.20	12		
5.437"						
5.437	6.749	6.757	0.625	55357	50S	S
5.500" 5 1/2"						
5.500	6.250	6.257	0.500	476842	470	S
5.500	6.312	6.316	1.250	6872S	470	S
5.500	6.500	6.507	0.562	417254	410	S
5.500	6.500	6.505	1.125	6873S	430	S
5.500	6.625	6.632	0.562	417360	410	S
5.500	6.625	6.632	0.670	3054	410	H
5.500	6.749	6.757	0.625	455073	450	S
5.500	6.750	6.758	0.575	416107	410	S
5.500	6.875	6.882	0.562	417361	410	S
5.500	6.997	7.004	1.250	7006S	430	S
5.500	7.000	7.007	0.625	415610	410	S
5.500	7.125	7.133	0.625	416191	410	S
5.500	7.500	7.507	0.562	456192	450	S
5.500	7.624	7.631	1.250	8635S	210	S
5.512" 140mm						
5.512	6.299	6.307	0.472	◆14X016012XX	320	S
	140	160	160.20	12		

Shaft	Bore	O.D.	Width	Part Number	Style	Matl
5.512	6.299	6.310	0.512	◆14X016013XX	350	S
	140	160	160.27	13		
5.512	6.299	6.310	0.512	231402	350	S
5.512	6.693	6.705	0.472	◆14X017012XX	320	S
	140	170	170.30	12		
5.512	6.693	6.701	0.551	◆710406	470	S
	140	170	170.21	14		
5.512	6.693	6.710	0.591	◆14X017015XX	350	S
	140	170	170.43	15		
5.512	7.087	7.098	0.472	◆14X018012XX	350	S
	140	180	180.30	12		
5.512	7.087	7.102	0.709	◆14X018018XX	320	S
	140	180	180.38	18		
5.625" 5 5/8" 143mm						
5.625	6.626	6.634	0.516	◆417555	410	S
	143	168.30	168.50	13.10		
5.625	6.874	6.882	0.500	417556	410	S
5.625	7.125	7.131	0.500	417040	410	S
5.669" 144mm						
5.669	6.299	6.309	0.472	◆14X416012XX	350	S
	144	160	160.25	12		
5.709" 145mm						
5.709	6.457	6.461	0.551	◆14X516414XX	470	S
	145	164	164.10	14		
5.709	6.457	10.398	0.551	◆710369	470	S
	145	164	264.10	14		
5.709	6.693	6.711	0.472	◆14X517012XX	350	S
	145	170	170.45	12		
148	170	170.28	15			
5.709	6.890	6.905	0.591	◆14X517515XX	350	S
	145	175	175.38	15		
5.709	7.087	7.098	0.472	◆14X518012XX	350	S
	145	180	180.28	12		
5.750" 5 3/4"						
5.750	6.624	6.632	0.625	415447	410	S
5.750	6.750	6.757	0.575	417362	410	S
5.750	6.875	6.882	0.562	417363	410	S
5.750	7.001	7.008	0.562	416666	410	S
5.750	7.125	7.132	0.562	417364	410	S
5.750	7.500	7.508	0.562	416039	410	S
5.750	7.874	7.881	0.750	416029	410	S
5.750	7.874	7.881	0.750	416029N	410	N
5.827" 148mm						
5.827	6.693	6.704	0.591	◆14X817015XX	350	S
	148	170	170.28	15		

Shaft	Bore	O.D.	Width	Part Number	Style	Matl
5.875" 5 7/8"						
5.875	7.125	7.133	0.500	416476	410	S
5.875	7.125	7.135	0.625	455075	450	S
5.875	7.500	7.508	0.562	455297	450	S
5.875	7.999	8.007	0.750	456052	450	S
5.875	8.001	8.007	0.750	3016	450	S
5.906" 150mm						
5.906	7.087	7.100	0.472	◆15X018012XX	350	S
	150	180	180.35	12		
5.906	7.087	7.100	0.591	◆15X018015XX	350	S
	150	180	180.35	15		
5.937"						
5.937	6.801	0.000	1.125	8907	#	S
5.937	7.502	7.508	0.562	417780	410	S
5.997" 6"						
5.997	7.125	7.131	0.500	39956		TDW-H T
6.000" 6"						
6.000	6.750	6.756	0.437	39807		TW-H T
6.000	6.750	6.757	0.500	2297V←	250	V
6.000	6.750	6.757	0.625	39823		TDW-H T
6.000	6.751	6.757	0.375	447793	440	S
6.000	7.000	7.008	0.500	415683	410	S
6.000	7.001	7.008	0.625	456055	450	V
6.000	7.125	7.132	0.562	417365	410	S
6.000	7.475	7.481	0.590	39715	#	T
6.000	7.500	7.508	0.562	415072	410	S
6.077"						
6.077	7.328	7.336	0.445	39889		TW-H T
6.077	7.328	7.336	0.445	39890		TW-H T
6.102" 155mm						
6.102	7.087	7.096	0.591	◆15X518015XX	320	S
	155	180	180.23	15		
6.125" 6 1/8"						
6.125	7.125	7.135	0.626	455330	450	S
6.125	7.500	7.508	0.562	415074	410	S
6.125	7.627	7.633	0.625	457874	450	S
6.142"						
6.142	7.087	7.094	0.591	712110←		TW T

Shaft	Bore	O.D.	Width	Part Number	Style	Matl
6.142	7.087	7.102	0.591	712122←		TFW-H T
6.187"						
6.187	7.500	7.507	0.562	455583N	450	N
6.198"						
6.198	7.328	7.336	0.354	39885		TFW-H T
6.198	7.328	7.336	0.445	39888		TFW-H T
6.202"						
6.202	7.329	7.336	0.377	39886		TDW-H T
6.204"						
6.204	7.328	7.336	0.562	2628	640	H
6.204	7.330	7.336	0.445	39887		TFW-H T
6.238"						
6.238	8.654	8.661	0.560	39044←	900	T
6.238	8.655	8.661	1.100	39883	900	T
6.250" 6 1/4"						
6.250	7.500	7.508	0.562	455480	450	S
6.250	7.500	7.508	0.562	455480V	450	V
6.250	7.750	7.758	0.500	417562	410	S
6.250	7.875	7.884	0.750	415854	410	S
6.299" 160mm						
6.299	7.283	7.297	0.394	◆16X018510XX	350	S
	160	185	185.35	10		
6.299	7.480	7.496	0.512	712118←		TFW-H T
6.299	7.480	7.494	0.591	◆16X019015XX	350	S
	160	190	190.35	15		
6.299	7.874	7.882	0.472	◆16X020012XX	320	S
	160	200	200.20	12		
6.299	7.874	7.882	0.591	◆16X020015XX	320	S
	160	200	200.20	15		
6.328"						
6.328	7.329	7.336	0.500	3807	640	H
6.375"						
6.375	7.875	7.883	0.500	417563	410	S
6.496"						
6.496	7.632	7.638	0.497	37586	#	T
6.496	9.600	9.606	0.540	39861	#	T

Shaft	Bore	O.D.	Width	Part Number	Style	Matl
6.500"		6 1/2"				
6.500	7.500	7.508	0.562	415294	410	S
6.500	7.500	7.508	0.562	455294	450	S
6.500	8.000	8.007	0.625	41509	TPDW	T
6.500	8.000	8.007	0.625	41510	TPDW	T
6.500	8.000	8.009	0.625	416229	410	S
6.513"		135mm				
6.513	6.693	6.708	0.472	◆13X517012XX	350	S
	135	170	170.38	12		
6.625"						
6.625	8.125	8.134	0.625	417298	410	S
6.693"		170mm				
6.693	7.874	7.888	0.591	◆17X020015XX	350	S
	170	200	200.35	15		
6.693	8.268	8.276	0.591	◆17X021015XX	320	S
	170	210	210.20	15		
6.750"		6 3/4"				
6.750	8.000	8.009	0.625	415327	410	S
6.750	8.007	8.017	0.625	416362	410	S
6.750	8.250	8.257	0.562	417596	410	S
6.750	8.500	8.509	0.625	416008	410	S
6.775"						
6.775	7.875	7.880	0.360	710562	2300	S
6.875"		6 7/8"				
6.875	7.875	7.883	0.625	455948	450	S
6.875	8.375	8.382	0.625	455584	450	S
6.890"		175mm				
6.890	7.874	7.888	0.591	◆17X520015XX	320	S
	175	200	200.35	15		
7.000"		7"				
7.000	8.000	8.009	0.625	416364	410	S
7.000	8.250	8.257	0.625	417597	410	S
7.000	8.375	8.382	0.625	417255	410	S
7.000	8.375	8.382	0.750	416674V	410	V
7.000	8.750	8.759	0.625	417564	410	S
7.000	9.313	9.321	0.625	415876	410	S
7.000	9.313	9.321	0.625	415876V	410	V

Shaft	Bore	O.D.	Width	Part Number	Style	Matl
7.087"		180mm				
7.087	8.268	8.281	0.591	◆18X021015XX	350	S
	180	210	210.35	15		
7.125"						
7.125	8.625	8.632	0.562	416077	410	S
7.250"		7 1/4"				
7.250	8.125	8.133	0.500	39701	TFW-H	T
7.250	8.125	8.132	0.940	39815	TDW-H	T
7.250	8.250	8.257	0.625	416044	410	S
7.250	8.750	8.759	0.750	415116	410	S
7.283"		185mm				
7.283	8.268	8.281	0.512	◆18X512013XX	350	S
	185	210	210.35	13		
7.375"		7 3/8"				
7.375	8.875	8.882	0.750	455117	450	S
7.375	9.000	9.010	0.750	415317	410	S
7.375	9.615	9.622	0.979	4353	#	V
7.375	9.615	9.622	0.979	4353V	#	V
7.480"		190mm				
7.480	8.661	8.675	0.630	◆19X022016XX	350	S
	190	220	220.35	16		
7.480	8.858	8.866	0.630	◆19X023016XX	320	S
	190	230	230.20	16		
7.500"		7 1/2"				
7.500	8.500	8.510	0.625	415867	410	S
7.500	8.500	8.509	0.625	455867V	450	V
7.500	9.000	9.010	0.750	415551	410	S
7.500	9.000	9.010	0.750	415551V	410	V
7.500	9.243	9.250	0.625	417283	410	S
7.625"		7 5/8"				
7.625	8.625	8.632	0.562	416102	410	S
7.625	9.125	9.133	0.625	417598	410	S
7.625	9.125	9.133	0.625	417598V	410	V
7.750"		7 3/4"				
7.750	10.000	10.008	0.750	417115	410	S
7.750	9.000	9.010	0.625	457299	450	S
7.750	9.250	9.260	0.625	455406	450	S

Shaft	Bore	O.D.	Width	Part Number	Style	Matl
7.874" 200mm						
7.874 200	9.055 230	9.069 230.35	0.591 15	◆20X023015XX	450	S
7.875" 7 7/8"						
7.875	10.000	10.008	0.625	417016	410	S
7.875	9.375	9.383	0.750	455121V	450	V
7.937"						
7.937	8.750	8.757	0.565	417817	410	S
7.995" 8"						
7.995	11.625	11.633	1.078	8724S	410	S
8.000" 8"						
8.000	10.000	10.008	0.625	417602	410	S
8.000	10.125	10.133	0.750	415052	410	S
8.000	11.624	11.632	0.750	7131	#	S
8.000	9.000	9.010	0.750	415656	410	S
8.000	9.250	9.258	0.625	417600	410	S
8.000	9.500	9.508	0.625	417601	410	S
8.125"						
8.125	10.125	10.130	0.750	455123	450	S
8.250" 8 1/4"						
8.250	10.250	10.260	0.750	415124	410	S
8.250	10.625	10.633	0.750	416951	410	S
8.250	11.500	11.507	0.750	416422	410	S
8.250	9.250	9.258	0.625	455475	450	S
8.250	9.500	9.509	0.625	458009V	450	V
8.268" 210mm						
8.268 210	9.449 240	9.463 240.35	0.591 15	◆21X024015XX	350	S
8.268 210	9.843 250	9.850 250.20	0.591 15	◆21X025015XX	320	S
8.375"						
8.375	10.375	10.385	0.625	417022	410	S
8.500" 8 1/2"						
8.500	10.000	10.008	0.625	417603	410	S
8.500	10.500	10.508	0.625	417604	410	S

Shaft	Bore	O.D.	Width	Part Number	Style	Matl
8.500	10.625	10.633	0.750	416394	410	S
8.500	9.500	9.509	0.625	455828V	450	V
8.625"						
8.625	10.625	10.635	0.750	417567	410	S
8.661" 220mm						
8.661 220	9.843 250	9.856 250.35	0.591 15	◆22X025015XX	350	S
8.750" 8 3/4"						
8.750	10.500	10.510	0.750	455966	450	S
8.750	10.750	10.758	0.750	415128	410	S
8.875"						
8.875	10.122	10.130	0.750	416657	410	S
8.875	10.875	10.885	0.750	455129	450	S
9.000" 9"						
9.000	10.000	10.010	0.750	455301	450	S
9.000	10.000	10.010	0.750	455301S	450	S
9.000	10.000	10.010	0.750	55301S	450	S
9.000	10.088	10.095	0.625	417940	410	S
9.000	10.250	10.260	0.750	455476	450	S
9.000	10.375	10.384	0.625	456462	450	S
9.000	10.376	10.384	0.625	2791	330	S
9.000	10.500	10.510	0.625	455462	450	S
9.000	11.000	11.008	0.750	415090	410	S
9.052"						
9.052	10.709	10.720	0.625	39893	TFW-H	T
9.052	10.709	10.720	0.625	39894	TFW-H	T
9.055" 230mm						
9.055 230	10.236 260	10.250 260.35	0.591 15	◆23X026015XX	350	S
9.250" 9 1/4"						
9.250	10.250	10.258	0.500	337426N	330	N
9.250	11.000	11.008	0.750	416257	410	S
9.250	11.250	11.260	0.750	415219	410	S
9.375"						
9.375	11.375	11.385	0.750	415871	410	S

Shaft	Bore	O.D.	Width	Part Number	Style	Matl
9.449"				240mm		
9.449	10.630	10.644	0.591	◆24X027015XX	350	S
	240	270	270.35	15		
9.449	11.024	11.031	0.630	◆24X028016XX	320	S
	240	280	280.20	16		
9.466"						
9.466	10.875	10.891	0.375	710800	2300	S
9.500"				9 1/2"		
9.500	11.500	11.508	0.625	417606	410	S
9.500	12.499	12.509	0.687	9555S	410	S
9.625"						
9.625	12.750	12.758	1.250	416381	410	S
9.750"				9 3/4"		
9.750	11.250	11.260	0.750	55078S	50S	S
9.910"						
9.910	10.995	11.005	0.625	417939	410	S
9.910	10.997	11.005	0.625	2792	330	S
9.910	10.997	11.005	0.625	456464	450	S
10.000"				10"		
10.000	11.000	11.008	0.625	417605	410	S
10.000	11.500	11.508	0.750	457096V	450	V
10.000	12.000	12.008	0.625	417020	410	S
10.250"				10 1/4"		
10.250	12.250	12.260	0.750	417570	410	S
10.500"				10 1/2"		
10.500	12.000	12.008	0.625	457997	450	S
10.500	12.500	12.508	1.000	415227	410	S
10.750"				10 3/4"		
10.750	13.374	13.381	1.250	416383	410	S

Shaft	Bore	O.D.	Width	Part Number	Style	Matl
11.000"				11"		
11.000	12.500	12.510	0.625	417571	410	S
11.000	13.000	13.010	0.750	415482	410	S
11.006"						
11.006	12.875	12.891	0.625	710925	2300	S
11.024"				280mm		
11.024	12.598	12.616	0.787	◆28X032020XX	320	S
	280	320	320.45	20		
11.220"						
11.220	12.250	12.260	0.945	39899	#	T
11.220	12.250	12.260	0.945	39900	#	T
11.500"				11 1/2"		
11.500	13.000	13.010	0.750	415077	410	S
11.500	13.500	13.508	0.750	415076	410	S
11.586"						
11.586	13.687	13.703	0.562	711000	2300	S
11.811"				300mm		
11.811	13.386	13.404	0.787	◆30X034020XX	320	S
	300	340	340.45	20		
12.000"				12"		
12.000	14.000	14.010	0.750	417608	410	S
13.797"						
13.797	15.500	15.513	0.437	711200	2300	S
16.250"				16 1/4"		
16.250	18.000	18.010	0.750	55103S	450	S

Styles VS1, VS3, & VS4

Style VS2

Shaft Diameter Range* (d1)		Shaft/mm (d1)	Width Shaft (A)	Overall Width (B)	Fitted Width (B1)	Width Tolerance (+/-)	Height (C)	Part Number	Style	Matl
0.11	0.14	3	0.08	0.12	0.10	0.012	0.06	800030	VS1	S
0.11	0.14	3	0.08	0.12	0.10	0.012	0.06	800034	VS1	V
0.14	0.18	4	0.09	0.15	0.12	0.016	0.08	800040	VS1	S
0.14	0.18	4	0.09	0.15	0.12	0.016	0.08	800044	VS1	V
0.18	0.21	5	0.09	0.15	0.12	0.016	0.08	800050	VS1	S
0.18	0.21	5	0.09	0.15	0.12	0.016	0.08	800054	VS1	V
0.18	0.21	5	0.15	0.21	0.18	0.016	0.08	800051	VS2	S
0.18	0.21	5	0.15	0.21	0.18	0.016	0.08	800055	VS2	V
0.21	0.26	6	0.09	0.15	0.12	0.016	0.08	800060	VS1	S
0.21	0.26	6	0.09	0.15	0.12	0.016	0.08	800064	VS1	V
0.21	0.26	6	0.15	0.21	0.18	0.016	0.08	800061	VS2	S
0.21	0.26	6	0.15	0.21	0.18	0.016	0.08	800065	VS2	V
0.26	0.31	7	0.09	0.15	0.12	0.016	0.08	800070	VS1	S
0.26	0.31	7	0.09	0.15	0.12	0.016	0.08	800074	VS1	V
0.26	0.31	7	0.15	0.21	0.18	0.016	0.08	800071	VS2	S
0.26	0.31	7	0.15	0.21	0.18	0.016	0.08	800075	VS2	V
0.31	0.37	8	0.09	0.15	0.12	0.016	0.08	800080	VS1	S
0.31	0.37	8	0.09	0.15	0.12	0.016	0.08	800084	VS1	V
0.31	0.37	8	0.15	0.21	0.18	0.016	0.08	800081	VS2	S
0.31	0.37	8	0.15	0.21	0.18	0.016	0.08	800085	VS2	V
0.37	0.45	10	0.13	0.22	0.18	0.020	0.12	800100	VS1	S
0.37	0.45	10	0.13	0.22	0.18	0.020	0.12	800104	VS1	V
0.37	0.45	10	0.22	0.30	0.26	0.020	0.12	800101	VS2	S
0.37	0.45	10	0.22	0.30	0.26	0.020	0.12	800105	VS2	V
0.45	0.49	12	0.13	0.22	0.18	0.020	0.12	800120	VS1	S
0.45	0.49	12	0.13	0.22	0.18	0.020	0.12	800124	VS1	V
0.45	0.49	12	0.22	0.30	0.26	0.020	0.12	800121	VS2	S
0.45	0.49	12	0.22	0.30	0.26	0.020	0.12	800125	VS2	V
0.49	0.53	13	0.13	0.22	0.18	0.020	0.12	800130	VS1	S
0.49	0.53	13	0.13	0.22	0.18	0.020	0.12	800134	VS1	V

* Select the larger V-Seal when the dimension d1 is on the boundary between two sizes of V-Seals

Shaft Diameter Range* (d1)		Shaft/mm (d1)	Width Shaft (A)	Overall Width (B)	Fitted Width (B1)	Width Tolerance (+/-)	Height (C)	Part Number	Style	Matl
0.53	0.61	14	0.13	0.22	0.18	0.020	0.12	800140	VS1	S
0.53	0.61	14	0.13	0.22	0.18	0.020	0.12	800144	VS1	V
0.53	0.61	14	0.22	0.30	0.26	0.020	0.12	800141	VS2	S
0.53	0.61	14	0.22	0.30	0.26	0.020	0.12	800145	VS2	V
0.61	0.69	16	0.13	0.22	0.18	0.020	0.12	800160	VS1	S
0.61	0.69	16	0.13	0.22	0.18	0.020	0.12	800164	VS1	V
0.61	0.69	16	0.22	0.30	0.26	0.020	0.12	800161	VS2	S
0.61	0.69	16	0.22	0.30	0.26	0.020	0.12	800165	VS2	V
0.69	0.75	18	0.13	0.22	0.18	0.020	0.12	800180	VS1	S
0.69	0.75	18	0.13	0.22	0.18	0.020	0.12	800184	VS1	V
0.69	0.75	18	0.22	0.30	0.26	0.020	0.12	800181	VS2	S
0.69	0.75	18	0.22	0.30	0.26	0.020	0.12	800185	VS2	V
0.75	0.83	20	0.18	0.30	0.24	0.030	0.16	800200	VS1	S
0.75	0.83	20	0.18	0.30	0.24	0.030	0.16	800204	VS1	V
0.75	0.83	20	0.31	0.41	0.35	0.030	0.16	800201	VS2	S
0.75	0.83	20	0.31	0.41	0.35	0.030	0.16	800205	VS2	V
0.83	0.95	22	0.18	0.30	0.24	0.030	0.16	800220	VS1	S
0.83	0.95	22	0.18	0.30	0.24	0.030	0.16	800224	VS1	V
0.83	0.95	22	0.31	0.41	0.35	0.030	0.16	800221	VS2	S
0.93	0.95	22	0.31	0.41	0.35	0.030	0.16	800225	VS2	V
0.95	1.07	25	0.18	0.30	0.24	0.030	0.16	800250	VS1	S
0.95	1.07	25	0.18	0.30	0.24	0.030	0.16	800254	VS1	V
0.95	1.07	25	0.31	0.41	0.35	0.030	0.16	800255	VS2	V
0.96	1.07	25	0.31	0.41	0.35	0.030	0.16	800251	VS2	S
1.07	1.14	28	0.18	0.30	0.24	0.030	0.16	800280	VS1	S
1.07	1.14	28	0.18	0.30	0.24	0.030	0.16	800284	VS1	V
1.07	1.14	28	0.31	0.41	0.35	0.030	0.16	800281	VS2	S
1.07	1.14	28	0.31	0.41	0.35	0.030	0.16	800285	VS2	V
1.14	1.22	30	0.18	0.30	0.24	0.030	0.16	800300	VS1	S
1.14	1.22	30	0.18	0.30	0.24	0.030	0.16	800304	VS1	V
1.14	1.22	30	0.31	0.41	0.35	0.030	0.16	800301	VS2	S
1.14	1.22	30	0.31	0.41	0.35	0.030	0.16	800305	VS2	V
1.22	1.30	32	0.18	0.30	0.24	0.030	0.16	800320	VS1	S
1.22	1.30	32	0.18	0.30	0.24	0.030	0.16	800324	VS1	V
1.22	1.30	32	0.31	0.41	0.35	0.030	0.16	800321	VS2	S
1.22	1.30	32	0.31	0.41	0.35	0.030	0.16	800325	VS2	V
1.30	1.42	35	0.18	0.30	0.24	0.030	0.16	800350	VS1	S
1.30	1.42	35	0.18	0.30	0.24	0.030	0.16	800354	VS1	V
1.30	1.42	35	0.31	0.41	0.35	0.030	0.16	800351	VS2	S
1.30	1.42	36	0.31	0.41	0.35	0.030	0.16	800355	VS2	V
1.42	1.50	38	0.18	0.30	0.24	0.030	0.16	800380	VS1	S
1.42	1.50	38	0.18	0.30	0.24	0.030	0.16	800384	VS1	V
1.42	1.50	38	0.31	0.41	0.35	0.030	0.16	800381	VS2	S
1.42	1.50	38	0.31	0.41	0.35	0.030	0.16	800385	VS2	V
1.50	1.70	40	0.21	0.35	0.28	0.040	0.20	800400	VS1	S
1.50	1.70	40	0.37	0.51	0.43	0.040	0.20	800401	VS2	S
1.50	1.70	40	0.37	0.51	0.43	0.040	0.20	800405	VS2	V
1.50	1.70	40	0.21	0.35	0.28	0.040	0.20	800404	VS1	V
1.70	1.89	45	0.21	0.35	0.28	0.040	0.20	800450	VS1	S
1.70	1.89	45	0.21	0.35	0.28	0.040	0.20	800454	VS1	V

Styles VS1, VS3, & VS4

Style VS2

Shaft Diameter Range* (d1)	Shaft/mm (d1)	Width Shaft (A)	Overall Width (B)	Fitted Width (B1)	Width Tolerance (+/-)	Height (C)	Part Number	Style	Matl	
1.70	1.89	45	0.37	0.51	0.43	0.040	0.20	800451	VS2	S
1.70	1.89	45	0.37	0.51	0.43	0.040	0.20	800455	VS2	V
1.89	2.09	50	0.21	0.35	0.28	0.040	0.20	800500	VS1	S
1.89	2.09	50	0.21	0.35	0.28	0.040	0.20	800504	VS1	V
1.89	2.09	50	0.37	0.51	0.43	0.040	0.20	800501	VS2	S
1.89	2.09	50	0.37	0.51	0.43	0.040	0.20	800505	VS2	V
2.09	2.29	55	0.21	0.35	0.28	0.040	0.20	800550	VS1	S
2.09	2.29	55	0.21	0.35	0.28	0.040	0.20	800554	VS1	V
2.09	2.29	55	0.37	0.51	0.43	0.040	0.20	800551	VS2	S
2.09	2.29	55	0.37	0.51	0.43	0.040	0.20	800555	VS2	V
2.29	2.48	60	0.21	0.35	0.28	0.040	0.20	800600	VS1	S
2.29	2.48	60	0.21	0.35	0.28	0.040	0.20	800604	VS1	V
2.29	2.48	60	0.37	0.51	0.43	0.040	0.20	800601	VS2	S
2.29	2.48	60	0.37	0.51	0.43	0.040	0.20	800605	VS2	V
2.48	2.68	65	0.21	0.35	0.28	0.040	0.20	800650	VS1	S
2.48	2.68	65	0.21	0.35	0.28	0.040	0.20	800654	VS1	V
2.48	2.68	65	0.37	0.51	0.43	0.040	0.20	800651	VS2	S
2.48	2.68	65	0.37	0.51	0.43	0.040	0.20	800655	VS2	V
2.68	2.88	70	0.26	0.43	0.35	0.050	0.24	800700	VS1	S
2.68	2.88	70	0.26	0.43	0.35	0.050	0.24	800704	VS1	V
2.68	2.88	70	0.44	0.61	0.53	0.050	0.24	800701	VS2	S
2.68	2.88	70	0.44	0.61	0.53	0.050	0.24	800705	VS2	V
2.88	3.07	75	0.26	0.43	0.35	0.050	0.24	800750	VS1	S
2.88	3.07	75	0.26	0.43	0.35	0.050	0.24	800754	VS1	V
2.88	3.07	75	0.44	0.61	0.53	0.050	0.24	800751	VS2	S
2.88	3.07	75	0.44	0.61	0.53	0.050	0.24	800755	VS2	V
3.07	3.27	80	0.26	0.43	0.35	0.050	0.24	800800	VS1	S
3.07	3.27	80	0.26	0.43	0.35	0.050	0.24	800804	VS1	V
3.07	3.27	80	0.44	0.61	0.53	0.050	0.24	800801	VS2	S
3.07	3.27	80	0.44	0.61	0.53	0.050	0.24	800805	VS2	V

* Select the larger V-Seal when the dimension d1 is on the boundary between two sizes of V-Seals

Shaft Diameter Range* (d1)	Shaft/mm (d1)	Width Shaft (A)	Overall Width (B)	Fitted Width (B1)	Width Tolerance (+/-)	Height (C)	Part Number	Style	Matl	
3.27	3.47	85	0.26	0.43	0.35	0.050	0.24	800850	VS1	S
3.27	3.47	85	0.26	0.43	0.35	0.050	0.24	800854	VS1	V
3.27	3.47	85	0.44	0.61	0.53	0.050	0.24	800851	VS2	S
3.27	3.47	85	0.44	0.61	0.53	0.050	0.24	800855	VS2	V
3.47	3.66	90	0.26	0.43	0.35	0.050	0.24	800900	VS1	S
3.47	3.66	90	0.26	0.43	0.35	0.050	0.24	800904	VS1	V
3.47	3.66	90	0.44	0.61	0.53	0.050	0.24	800901	VS2	S
3.47	3.66	90	0.44	0.61	0.53	0.050	0.24	800905	VS2	V
3.66	3.86	95	0.26	0.43	0.35	0.050	0.24	800950	VS1	S
3.66	3.86	95	0.26	0.43	0.35	0.050	0.24	800954	VS1	V
3.66	3.86	95	0.44	0.61	0.53	0.050	0.24	800951	VS2	S
3.66	3.86	95	0.44	0.61	0.53	0.050	0.24	800955	VS2	V
3.86	4.14	100	0.26	0.43	0.35	0.050	0.24	801000	VS1	S
3.86	4.14	100	0.26	0.43	0.35	0.050	0.24	801004	VS1	V
3.86	4.14	100	0.44	0.61	0.53	0.050	0.24	801001	VS2	S
3.86	4.14	100	0.44	0.61	0.53	0.050	0.24	801005	VS2	V
4.14	4.53	110	0.31	0.50	0.41	0.060	0.28	801100	VS1	S
4.14	4.53	110	0.31	0.50	0.41	0.060	0.28	801104	VS1	V
4.14	4.53	110	0.52	0.71	0.61	0.060	0.28	801101	VS2	S
4.14	4.53	110	0.52	0.71	0.61	0.060	0.28	801105	VS2	V
4.53	4.92	120	0.31	0.50	0.41	0.060	0.28	801200	VS1	S
4.53	4.92	120	0.31	0.50	0.41	0.060	0.28	801204	VS1	V
4.53	4.92	120	0.52	0.71	0.61	0.060	0.28	801201	VS2	S
4.53	4.92	120	0.52	0.71	0.61	0.060	0.28	801205	VS2	V
4.92	5.32	130	0.31	0.50	0.41	0.060	0.28	801300	VS1	S
4.92	5.32	130	0.31	0.50	0.41	0.060	0.28	801304	VS1	V
4.92	5.32	130	0.52	0.71	0.61	0.060	0.28	801301	VS2	S
4.92	5.32	130	0.52	0.71	0.61	0.060	0.28	801305	VS2	V
5.32	5.71	140	0.24	0.41	0.31	0.060	0.26	801402	VS3	S
5.32	5.71	140	0.24	0.41	0.31	0.060	0.26	801406	VS3	V
5.32	5.71	140	0.31	0.50	0.41	0.060	0.28	801400	VS1	S
5.32	5.71	140	0.31	0.50	0.41	0.060	0.28	801404	VS1	V
5.32	5.71	140	0.52	0.71	0.61	0.060	0.28	801401	VS2	S
5.32	5.71	140	0.52	0.71	0.61	0.060	0.28	801405	VS2	V
5.71	6.10	150	0.24	0.41	0.31	0.060	0.26	801502	VS3	S
5.71	6.10	150	0.24	0.41	0.31	0.060	0.26	801506	VS3	V
5.71	6.10	150	0.31	0.50	0.41	0.060	0.28	801500	VS1	S
5.71	6.10	150	0.31	0.50	0.41	0.060	0.28	801504	VS1	V
5.71	6.10	150	0.52	0.71	0.61	0.060	0.28	801501	VS2	S
5.71	6.10	150	0.52	0.71	0.61	0.060	0.28	801505	VS2	V
6.10	6.50	160	0.24	0.41	0.31	0.060	0.26	801602	VS3	S
6.10	6.50	160	0.24	0.41	0.31	0.060	0.26	801606	VS3	V
6.10	6.50	160	0.35	0.57	0.47	0.070	0.32	801600	VS1	S
6.10	6.50	160	0.35	0.57	0.47	0.070	0.32	801604	VS1	V
6.10	6.50	160	0.59	0.81	0.71	0.070	0.32	801601	VS2	S
6.10	6.50	160	0.59	0.81	0.71	0.070	0.32	801605	VS2	V
6.50	6.89	170	0.24	0.41	0.31	0.060	0.26	801702	VS3	S
6.50	6.89	170	0.24	0.41	0.31	0.060	0.26	801706	VS3	V
6.50	6.89	170	0.35	0.57	0.47	0.070	0.32	801700	VS1	S
6.50	6.89	170	0.35	0.57	0.47	0.070	0.32	801704	VS1	V

Styles VS1, VS3, & VS4

Style VS2

Shaft Diameter Range* (d1)		Shaft/mm (d1)	Width Shaft (A)	Overall Width (B)	Fitted Width (B1)	Width Tolerance (+/-)	Height (C)	Part Number	Style	Matl
6.50	6.89	170	0.59	0.81	0.71	0.070	0.32	801701	VS2	S
6.50	6.89	170	0.59	0.81	0.71	0.070	0.32	801705	VS2	V
6.89	7.29	180	0.24	0.41	0.31	0.060	0.26	801802	VS3	S
6.89	7.29	180	0.24	0.41	0.31	0.060	0.26	801806	VS3	V
6.89	7.29	180	0.35	0.57	0.47	0.070	0.32	801800	VS1	S
6.89	7.29	180	0.35	0.57	0.47	0.070	0.32	801804	VS1	V
6.89	7.29	180	0.59	0.81	0.71	0.070	0.32	801801	VS2	S
6.89	7.29	180	0.59	0.81	0.71	0.070	0.32	801805	VS2	V
7.29	7.68	190	0.24	0.41	0.31	0.060	0.26	801902	VS3	S
7.29	7.68	190	0.24	0.41	0.31	0.060	0.26	801906	VS3	V
7.29	7.68	190	0.35	0.57	0.47	0.070	0.32	801900	VS1	S
7.29	7.68	190	0.35	0.57	0.47	0.070	0.32	801904	VS1	V
7.29	7.68	190	0.59	0.81	0.71	0.070	0.32	801901	VS2	S
7.29	7.68	190	0.59	0.81	0.71	0.070	0.32	801905	VS2	V
7.48	8.27	200	0.24	0.41	0.31	0.060	0.26	802002	VS3	S
7.48	8.27	200	0.24	0.41	0.31	0.060	0.26	802006	VS3	V
7.48	8.27	200	0.56	0.98	0.79	0.160	0.59	802000	VS1	S
7.48	8.27	200	0.56	0.98	0.79	0.160	0.59	802004	VS1	V
7.68	8.27	199	0.35	0.57	0.47	0.070	0.32	801990	VS1	S
7.68	8.27	199	0.35	0.57	0.47	0.070	0.32	801994	VS1	V
7.68	8.27	199	0.59	0.81	0.71	0.070	0.32	801991	VS2	S
7.68	8.27	199	0.59	0.81	0.71	0.070	0.32	801995	VS2	V
8.27	9.25	220	0.24	0.41	0.31	0.060	0.26	802202	VS3	S
8.27	9.25	220	0.24	0.41	0.31	0.060	0.26	802206	VS3	V
8.27	9.25	220	0.56	0.98	0.79	0.160	0.59	802200	VS1	S
8.27	9.25	220	0.56	0.98	0.79	0.160	0.59	802204	VS1	V
9.25	10.43	250	0.24	0.41	0.31	0.060	0.26	802502	VS3	S
9.25	10.43	250	0.24	0.41	0.31	0.060	0.26	802506	VS3	V
9.25	10.43	250	0.56	0.98	0.79	0.160	0.59	802500	VS1	S
9.25	10.43	250	0.56	0.98	0.79	0.160	0.59	802504	VS1	V

* Select the larger V-Seal when the dimension d1 is on the boundary between two sizes of V-Seals

Shaft Diameter Range* (d1)	Shaft/mm (d1)	Width Shaft (A)	Overall Width (B)	Fitted Width (B1)	Width Tolerance (+/-)	Height (C)	Part Number	Style	Matl	
10.43	11.42	275	0.24	0.41	0.31	0.060	0.26	802752	VS3	S
10.43	11.42	275	0.24	0.41	0.31	0.060	0.26	802756	VS3	V
10.43	11.42	275	0.56	0.98	0.79	0.160	0.59	802750	VS1	S
10.43	11.42	275	0.56	0.98	0.79	0.160	0.59	802754	VS1	V
11.42	12.20	300	0.22	0.41	0.31	0.060	0.26	803002	VS3	S
11.42	12.20	300	0.24	0.41	0.31	0.060	0.26	803006	VS3	V
11.42	12.20	300	0.56	0.98	0.79	0.160	0.59	803000	VS1	S
11.42	12.20	300	0.56	0.98	0.79	0.160	0.59	803004	VS1	V
12.20	13.19	325	0.24	0.41	0.31	0.060	0.26	803252	VS3	S
12.20	13.19	325	0.24	0.41	0.31	0.060	0.26	803256	VS3	V
12.20	13.19	325	0.56	0.98	0.79	0.160	0.59	803250	VS1	S
12.20	13.19	325	0.56	0.98	0.79	0.160	0.59	803254	VS1	V
13.19	14.37	350	0.24	0.41	0.31	0.060	0.26	803502	VS3	S
13.19	14.37	350	0.24	0.41	0.31	0.060	0.26	803506	VS3	V
13.19	14.37	350	0.56	0.98	0.79	0.160	0.59	803500	VS1	S
13.19	14.37	350	0.56	0.98	0.79	0.160	0.59	803504	VS1	V
14.37	15.35	375	0.24	0.41	0.31	0.060	0.26	803752	VS3	S
14.37	15.35	375	0.24	0.41	0.31	0.060	0.26	803756	VS3	V
14.37	15.35	375	0.56	0.98	0.79	0.160	0.59	803750	VS1	S
14.37	15.35	375	0.56	0.98	0.79	0.160	0.59	803754	VS1	V
15.35	16.93	400	0.24	0.41	0.31	0.060	0.26	804002	VS3	S
15.35	16.93	400	0.24	0.41	0.31	0.060	0.26	804006	VS3	V
15.35	16.93	400	0.56	0.98	0.79	0.160	0.59	804000	VS1	S
15.35	16.93	400	0.56	0.98	0.79	0.160	0.59	804004	VS1	V
16.93	18.90	450	0.24	0.41	0.31	0.060	0.26	804502	VS3	S
16.93	18.90	450	0.24	0.41	0.31	0.060	0.26	804506	VS3	V
16.93	18.90	450	0.56	0.98	0.79	0.160	0.59	804500	VS1	S
16.93	18.90	450	0.56	0.98	0.79	0.160	0.59	804504	VS1	V
17.72	17.91	450	0.56	0.98	0.79	0.160	0.59	804503	VS4	S
18.90	20.87	500	0.24	0.41	0.31	0.060	0.26	805002	VS3	S
18.90	20.87	500	0.56	0.98	0.79	0.160	0.59	805000	VS1	S
18.90	20.87	500	0.56	0.98	0.79	0.160	0.59	805004	VS1	V
19.69	19.88	500	0.56	0.98	0.79	0.160	0.59	805003	VS4	S
20.08	20.28	510	0.56	0.98	0.79	0.160	0.59	805103	VS4	S
20.47	20.67	520	0.56	0.98	0.79	0.160	0.59	805203	VS4	S
20.87	22.83	550	0.24	0.41	0.31	0.060	0.26	805502	VS3	S
20.87	21.06	530	0.56	0.98	0.79	0.160	0.59	805303	VS4	S
20.87	22.86	550	0.56	0.98	0.79	0.160	0.59	805500	VS1	S
20.87	22.83	550	0.56	0.98	0.79	0.160	0.59	805504	VS1	V
21.26	21.46	540	0.56	0.98	0.79	0.160	0.59	805403	VS4	S
21.65	21.85	550	0.56	0.98	0.79	0.160	0.59	805503	VS4	S
22.05	22.24	560	0.56	0.98	0.79	0.160	0.59	805603	VS4	S
22.44	22.64	570	0.56	0.98	0.79	0.160	0.59	805703	VS4	S
22.83	24.80	600	0.24	0.41	0.31	0.060	0.26	806002	VS3	S
22.83	24.80	600	0.56	0.98	0.79	0.160	0.59	806000	VS1	S
22.83	24.80	600	0.56	0.98	0.79	0.160	0.59	806004	VS1	V
22.84	23.03	580	0.56	0.98	0.79	0.160	0.59	805803	VS4	S
23.23	23.62	590	0.56	0.98	0.79	0.160	0.59	805903	VS4	S
23.62	24.02	600	0.56	0.98	0.79	0.160	0.59	806003	VS4	S
24.02	24.41	610	0.56	0.98	0.79	0.160	0.59	806103	VS4	S

Styles VS1, VS3, & VS4

Style VS2

Shaft Diameter Range* (d1)		Shaft/mm (d1)	Width Shaft (A)	Overall Width (B)	Fitted Width (B1)	Width Tolerance (+/-)	Height (C)	Part Number	Style	Matl
24.41	24.80	620	0.56	0.98	0.79	0.160	0.59	806203	VS4	S
24.80	25.20	630	0.56	0.98	0.79	0.160	0.59	806303	VS4	S
24.80	26.18	650	0.56	0.98	0.79	0.160	0.59	806500	VS1	S
25.20	25.59	640	0.56	0.98	0.79	0.160	0.59	806403	VS4	S
25.59	25.98	650	0.56	0.98	0.79	0.160	0.59	806503	VS4	S
26.18	27.76	700	0.56	0.98	0.79	0.160	0.59	807000	VS1	S
27.10	27.50	690	0.56	0.98	0.79	0.160	0.59	806903	VS4	S
27.56	27.95	700	0.56	0.98	0.79	0.160	0.59	807003	VS4	S
27.76	29.33	725	0.56	0.98	0.79	0.160	0.59	807250	VS1	S
29.33	30.91	750	0.56	0.98	0.79	0.160	0.59	807500	VS1	S
29.53	29.84	750	0.56	0.98	0.79	0.160	0.59	807503	VS4	S
30.40	30.80	780	0.56	0.98	0.79	0.160	0.59	807803	VS4	S
30.91	32.68	800	0.56	0.98	0.79	0.160	0.59	808000	VS1	S
31.18	31.54	800	0.56	0.98	0.79	0.160	0.59	808003	VS4	S
31.50	33.26	820	0.56	0.98	0.79	0.160	0.59	808203	VS4	S
32.68	34.45	850	0.56	0.98	0.79	0.160	0.59	808500	VS1	S
33.11	33.50	850	0.56	0.98	0.79	0.160	0.59	808503	VS4	S
34.45	36.22	900	0.56	0.98	0.79	0.160	0.59	809000	VS1	S
35.12	35.91	900	0.56	0.98	0.79	0.160	0.59	809003	VS4	S
36.22	37.99	950	0.56	0.98	0.79	0.160	0.59	809500	VS1	S
37.17	37.60	950	0.56	0.98	0.79	0.160	0.59	809503	VS4	S
37.99	39.96	1000	0.56	0.98	0.79	0.160	0.59	810000	VS1	S
39.33	39.79	1000	0.56	0.98	0.79	0.160	0.59	810003	VS4	S
39.96	41.93	1050	0.56	0.98	0.79	0.160	0.59	810500	VS1	S
41.10	41.90	1060	0.56	0.98	0.79	0.160	0.59	810603	VS4	S
41.93	43.90	1100	0.56	0.98	0.79	0.160	0.59	811000	VS1	S
42.72	43.50	1100	0.56	0.98	0.79	0.160	0.59	811003	VS4	S
43.90	45.87	1150	0.56	0.98	0.79	0.160	0.59	811500	VS1	S
45.87	47.84	1200	0.56	0.98	0.79	0.160	0.59	812000	VS1	S
46.65	47.44	1200	0.56	0.98	0.79	0.160	0.59	812003	VS4	S

* Select the larger V-Seal when the dimension d1 is on the boundary between two sizes of V-Seals

Shaft Diameter Range* (d1)	Shaft/mm (d1)	Width Shaft (A)	Overall Width (B)	Fitted Width (B1)	Width Tolerance (+/-)	Height (C)	Part Number	Style	Matl	
47.84	50.00	1250	0.56	0.98	0.79	0.160	0.59	812500	VS1	S
50.00	51.97	1300	0.56	0.98	0.79	0.160	0.59	813000	VS1	S
50.98	51.77	1300	0.56	0.98	0.79	0.160	0.59	813003	VS4	S
51.97	53.94	1300	0.56	0.98	0.79	0.160	0.59	813500	VS1	S
52.76	53.74	1350	0.56	0.98	0.79	0.160	0.59	813503	VS4	S
53.94	55.91	1400	0.56	0.98	0.79	0.160	0.59	814000	VS1	S
54.72	55.71	1400	0.56	0.98	0.79	0.160	0.59	814003	VS4	S
55.91	57.87	1450	0.56	0.98	0.79	0.160	0.59	814500	VS1	S
56.69	57.68	1450	0.56	0.98	0.79	0.160	0.59	814503	VS4	S
57.87	59.84	1500	0.56	0.98	0.79	0.160	0.59	815000	VS1	S
58.66	59.65	1500	0.56	0.98	0.79	0.160	0.59	815003	VS4	S
59.84	61.81	1550	0.56	0.98	0.79	0.160	0.59	815500	VS1	S
60.63	61.81	1550	0.56	0.98	0.79	0.160	0.59	815503	VS4	S
61.81	63.78	1600	0.56	0.98	0.79	0.160	0.59	816000	VS1	S
62.99	64.57	1600	0.56	0.98	0.79	0.160	0.59	816003	VS4	S
63.78	65.75	1650	0.56	0.98	0.79	0.160	0.59	816500	VS1	S
64.57	66.14	1650	0.56	0.98	0.79	0.160	0.59	816503	VS4	S
65.75	67.72	1700	0.56	0.98	0.79	0.160	0.59	817000	VS1	S
66.15	67.72	1700	0.56	0.98	0.79	0.160	0.59	817003	VS4	S
67.72	69.69	1750	0.56	0.98	0.79	0.160	0.59	817500	VS1	S
67.72	69.49	1750	0.56	0.98	0.79	0.160	0.59	817503	VS4	S
69.46	71.26	1800	0.56	0.98	0.79	0.160	0.59	818003	VS4	S
69.69	71.65	1800	0.56	0.98	0.79	0.160	0.59	818000	VS1	S
71.26	73.03	1850	0.56	0.98	0.79	0.160	0.59	818503	VS4	S
71.65	73.62	1850	0.56	0.98	0.79	0.160	0.59	818500	VS1	S
73.03	75.00	1900	0.56	0.98	0.79	0.160	0.59	819003	VS4	S
73.62	75.59	1900	0.56	0.98	0.79	0.160	0.59	819000	VS1	S
75.00	76.97	1950	0.56	0.98	0.79	0.160	0.59	819503	VS4	S
75.59	77.56	1950	0.56	0.98	0.79	0.160	0.59	819500	VS1	S
76.90	79.10	2000	0.56	0.98	0.79	0.160	0.59	820003	VS4	S
77.56	79.53	1999	0.56	0.98	0.79	0.160	0.59	819990	VS1	S

Shaft	Bore	O.D.	Width	Part Number	Type	Matl
2.250	3.372	3.377	0.475	370219A	Unitized	S
2.359	3.938	3.952	0.575	370199A	Unitized	V
2.740	3.937	3.942	0.565	* 370155A	Unitized	S
2.750	3.779	3.792	0.767	370352A	Unitized	S
2.752	3.937	3.942	0.565	* 370127A	Unitized	S
<hr/>						
2.875	3.875	3.889	0.500	370150A	Unitized	S
2.875	4.125	4.130	0.842	370010A	Unitized	S
2.875	4.175	4.181	0.822	370054A	Unitized	S
2.938	3.750	3.765	0.530	* 370223A	Unitized	S
2.948	4.725	4.738	0.526	370211A	Unitized	S
<hr/>						
3.125	4.174	4.188	0.500	370145A	Unitized	S
3.125	4.500	4.506	0.605	370014A	Unitized	S
3.125	4.625	4.631	0.605	370046A	Unitized	S
3.187	5.000	5.006	0.765	370029A	Unitized	S
3.250	4.500	4.506	0.605	370018A	Unitized	S
<hr/>						
3.312	4.501	4.506	0.605	370191A	Unitized	S
3.312	5.000	5.006	0.937	370013A	Unitized	S
3.437	4.755	4.761	0.605	370047A	Unitized	S
3.500	4.450	4.456	0.843	370179A	Unitized	S
3.500	4.543	4.558	0.788	370132A	Unitized	S
<hr/>						
3.500	4.751	4.757	0.605	370169A	Unitized	S
3.500	4.842	4.847	0.910	* 380001A	Unitized	T
3.500	4.842	4.848	0.925	370001A	Unitized	S
3.500	5.000	5.006	1.000	370002A	Unitized	S
3.539	5.277	5.291	0.604	370212A	Unitized	V
<hr/>						
3.625	4.810	4.823	0.921	370012A	Unitized	S
3.625	5.000	5.014	0.875	370011A	Unitized	S
3.875	5.126	5.132	0.605	370033A	Unitized	S
3.875	5.376	5.381	0.985	370165A	Unitized	S
3.875	5.501	5.515	0.875	370024A	Unitized	S
<hr/>						
3.875	5.690	5.706	0.770	* 380023A	Unitized	T
3.875	5.690	5.706	0.875	370023A	Unitized	S
3.937	5.372	5.378	1.015	370008A	Unitized	S
3.937	5.501	5.507	0.937	370009A	Unitized	S
4.000	5.248	5.254	0.605	* 370087A	Unitized	S
<hr/>						
4.000	5.375	5.381	1.000	370015A	Unitized	S
4.000	5.626	5.632	0.605	370066A	Unitized	S
4.000	5.757	5.798	0.600	370349A	Unitized	S
4.000	5.757	5.772	0.930	370036A	Unitized	S
4.000	5.757	5.772	0.930	* 380036A	Unitized	T
<hr/>						
4.040	5.122	5.130	0.945	370198A	Unitized	S
4.125	5.375	5.381	0.605	370094A	Unitized	S
4.166	5.500	5.506	0.605	370106A	Unitized	S
4.250	6.000	6.008	1.000	* 380065A	Unitized	T
4.250	6.008	6.022	1.000	370065A	Unitized	S
<hr/>						
4.250	6.035	6.047	0.915	370107A	Unitized	S
4.250	6.250	6.256	1.188	370031A	Unitized	S
4.250	6.250	6.256	1.188	* 380031A	Unitized	T
4.265	6.064	6.071	0.605	370030A	Unitized	S
4.375	5.757	5.798	0.600	370338A	Unitized	S

Shaft	Bore	O.D.	Width	Part Number	Type	Matl
4.375	5.757	5.763	1.000	370037A	Unitized	S
4.375	5.905	5.911	1.000	370048A	Unitized	S
4.375	5.905	5.910	1.000	370182A	Unitized	S
4.375	5.905	5.918	1.015	*380048A	Unitized	T
4.375	6.251	6.256	0.605	370019A	Unitized	S
4.375	6.311	6.317	1.090	370034A	Unitized	S
4.500	5.375	5.391	0.984	370124A	Unitized	S
4.500	5.500	5.515	0.675	370178A	Unitized	S
4.500	5.750	5.756	0.960	370022A	Unitized	S
4.500	5.750	5.756	0.960	*380022A	Unitized	T
4.500	5.876	5.892	0.984	370131A	Unitized	S
4.500	5.876	5.892	0.984	*380131A	Unitized	T
4.500	6.000	6.007	0.984	370020A	Unitized	S
4.500	6.251	6.265	0.610	370021A	Unitized	S
4.500	6.310	6.316	1.175	370086A	Unitized	S
4.500	6.441	6.447	0.937	370192A	Unitized	S
4.500	6.622	6.629	1.093	370078A	Unitized	S
4.625	5.999	6.008	0.840	370025A	Unitized	S
4.625	5.999	6.006	0.890	370216A	Unitized	S
4.625	5.999	6.005	0.937	*380025A	Unitized	T
4.625	6.622	6.629	1.093	370051A	Unitized	S
4.635	6.007	6.014	0.937	370026A	Unitized	S
4.724	5.906	5.912	0.590	370220A	Unitized	S
4.765	5.999	6.006	1.031	370181A	Unitized	S
4.765	6.250	6.257	1.050	370173A	Unitized	S
4.765	6.251	6.265	0.605	370005A	Unitized	S
4.765	6.311	6.318	1.078	370003A	Unitized	S
4.765	6.311	6.318	1.132	*380003A	Unitized	T
4.765	6.999	7.006	1.250	370006A	Unitized	S
4.768	6.999	7.039	0.735	*370224A	Unitized	S
4.812	6.311	6.316	1.062	370027A	Unitized	S
4.812	6.500	6.507	0.865	370004A	Unitized	S
4.875	6.001	6.015	0.625	370195A	Unitized	S
4.875	6.373	6.379	0.921	370007A	Unitized	S
4.875	6.437	6.444	0.921	370057A	Unitized	S
4.875	6.500	6.506	1.000	370121A	Unitized	S
4.875	6.622	6.629	1.000	370109A	Unitized	S
5.000	6.250	6.256	0.605	370063A	Unitized	S
5.000	6.250	6.256	1.375	370028A	Unitized	S
5.000	6.622	6.629	1.093	370166A	Unitized	S
5.000	7.000	7.006	1.000	*370154A	Unitized	S
5.000	7.000	7.015	1.130	370215A	Unitized	V
5.000	7.437	7.444	0.605	370038A	Unitized	S
5.250	7.375	7.386	1.000	370069A	Unitized	S
5.500	7.125	7.132	1.187	370043A	Unitized	S
5.500	7.250	7.256	1.187	370120A	Unitized	S
5.500	7.437	7.444	1.000	370039A	Unitized	S
5.625	7.186	7.194	0.906	370064A	Unitized	S
5.640	7.501	7.507	0.605	370119A	Unitized	S
6.000	7.875	7.881	0.605	*370077A	Unitized	S

Shaft	Bore	O.D.	Width	Part Number	Type	Matl
6.625	8.007	8.014	0.605	*370149A	Unitized	S
7.250	8.750	8.758	0.605	370175A	Unitized	S
7.375	9.054	9.063	1.062	*370082A	Unitized	S
7.875	10.234	10.242	0.605	*370151A	Unitized	S

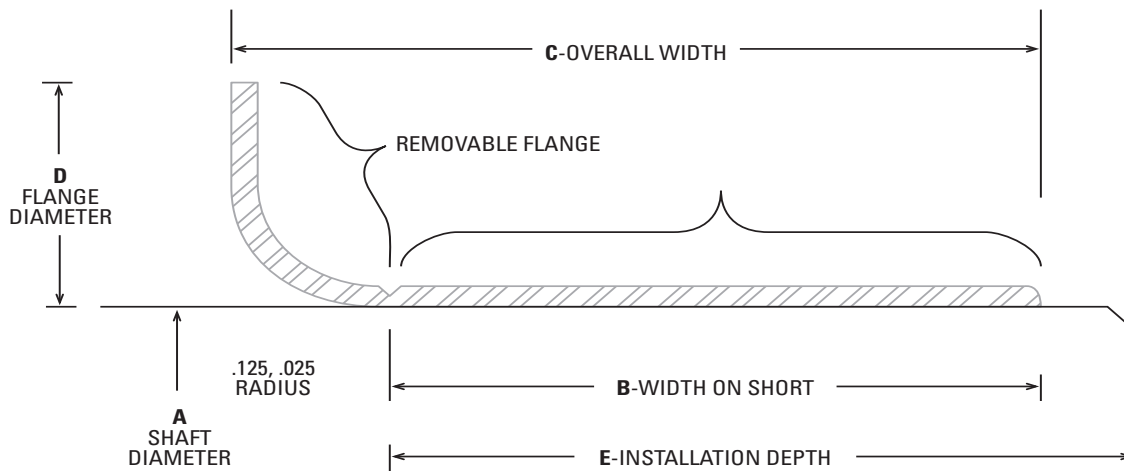

Shaft Diameter Range (A)	Width on Shaft (B)	Overall Width (C)	Flange Diameter (D)	Installation Depth (E)	Part Number
0.469	0.475	0.236	0.331	0.472	KWK99049
0.498	0.502	0.250	0.344	2.008	KWK99050
0.560	0.566	0.250	0.391	1.831	KWK99056
0.589	0.593	0.197	0.354	0.425	KWK99059
0.623	0.627	0.313	0.406	2.000	KWK99062
0.626	0.630	0.313	0.438	2.000	KWK99058
0.667	0.671	0.315	0.433	2.008	KWK99068
0.682	0.686	0.313	0.438	2.000	KWK99060
0.704	0.709	0.315	0.433	1.811	KWK99082
0.748	0.752	0.313	0.438	2.000	KWK99076
0.748	0.752	0.375	0.500	2.000	KWK99075
0.759	0.761	0.313	0.438	2.000	KWK99081
0.780	0.784	0.313	0.438	2.000	KWK99080
0.785	0.789	0.313	0.433	2.000	KWK99078
0.857	0.861	0.250	0.375	2.000	KWK99086
0.861	0.866	0.315	0.472	1.813	KWK99085
0.873	0.877	0.313	0.438	2.000	KWK99087
0.908	0.912	0.313	0.438	1.847	KWK99091
0.966	0.970	0.313	0.438	2.000	KWK99094
0.966	0.970	0.625	0.719	2.000	KWK99096
0.982	0.986	0.313	0.433	2.000	KWK99098
0.998	1.002	0.313	0.438	2.000	KWK99101
1.019	1.024	0.313	0.472	1.813	KWK99103
1.060	1.064	0.313	0.438	2.812	KWK99106
1.087	1.091	0.313	0.438	0.625	KWK99108
1.100	1.104	0.375	0.500	2.813	KWK99111
1.123	1.127	0.313	0.438	0.688	KWK99112
1.154	1.158	0.375	0.500	0.688	KWK99120
1.173	1.178	0.313	0.438	0.688	KWK99122
1.179	1.184	0.315	0.433	0.688	KWK99114

Shaft Diameter Range (A)		Width on Shaft (B)	Overall Width (C)	Flange Diameter (D)	Installation Depth (E)	Part Number
1.185	1.190	0.313	0.438	1.400	0.875	KWK99118
1.216	1.222	0.315	0.438	1.575	0.688	KWK99123
1.237	1.243	0.315	0.438	1.540	0.688	KWK99141
1.247	1.253	0.313	0.438	1.500	0.688	KWK99125
1.257	1.263	0.315	0.437	1.496	0.709	KWK99128
<hr/>						
1.308	1.314	0.250	0.375	1.600	0.813	KWK99129
1.310	1.316	0.500	0.625	1.594	0.813	KWK99131
1.336	1.342	0.500	0.625	1.638	0.813	KWK99134
1.371	1.377	0.313	0.438	1.638	0.813	KWK99133
1.371	1.377	0.500	0.625	1.638	0.813	KWK99138
<hr/>						
1.375	1.381	0.512	0.630	1.638	0.812	KWK99139
1.412	1.417	0.518	0.669	1.689	0.984	KWK99146
1.432	1.438	0.563	0.688	1.781	1.000	KWK99143
1.435	1.441	0.375	0.500	1.781	1.016	KWK99144
1.453	1.460	0.375	0.500	1.781	0.812	KWK99145
<hr/>						
1.490	1.496	0.512	0.669	1.780	0.984	KWK99147
1.497	1.503	0.375	0.500	1.781	1.016	KWK99150
1.497	1.503	0.563	0.688	1.781	1.000	KWK99149
1.520	1.526	0.438	0.563	1.859	1.016	KWK99152
1.549	1.555	0.438	0.563	1.859	1.000	KWK99155
<hr/>						
1.559	1.565	0.563	0.688	1.859	1.000	KWK99156
1.572	1.578	0.512	0.630	1.850	1.023	KWK99157
1.602	1.608	0.500	0.641	1.938	1.000	KWK99160
1.622	1.628	0.313	0.438	1.875	1.016	KWK99161
1.623	1.628	0.563	0.688	1.875	0.813	KWK99162
<hr/>						
1.647	1.654	0.445	0.571	2.087	0.827	KWK99166
1.647	1.654	0.563	0.688	2.087	0.827	KWK99169
1.684	1.690	0.563	0.688	1.906	0.875	KWK99168
1.685	1.691	0.313	0.438	1.906	0.875	KWK99167
1.715	1.721	0.563	0.688	2.031	0.813	KWK99171
<hr/>						
1.736	1.742	0.375	0.500	2.063	0.813	KWK99170
1.747	1.753	0.375	0.500	2.055	0.813	KWK99172
1.747	1.753	0.531	0.625	2.063	0.875	KWK99180
1.747	1.753	0.563	0.688	2.063	0.813	KWK99174
1.747	1.753	0.750	0.875	2.063	0.813	KWK99175
<hr/>						
1.761	1.767	0.563	0.688	2.063	0.813	KWK88176
1.761	1.767	0.563	0.688	2.063	0.813	KWK99176
1.769	1.775	0.551	0.669	2.087	0.812	KWK99177
1.778	1.784	0.675	0.800	2.125	1.000	KWK88179
1.778	1.784	0.675	0.800	2.125	1.062	KWK99179
<hr/>						
1.809	1.815	0.563	0.688	2.156	1.000	KWK99181
1.857	1.863	0.563	0.688	2.156	1.000	KWK99185
1.866	1.872	0.889	1.025	2.187	1.000	KWK88186
1.866	1.872	0.889	1.025	2.187	1.000	KWK99186
1.872	1.878	0.175	0.295	2.203	0.744	KWK99190
<hr/>						
1.872	1.878	0.295	0.415	2.203	0.744	KWK99188
1.872	1.878	0.375	0.516	2.203	1.050	KWK99184
1.872	1.878	0.563	0.688	2.203	1.000	KWK88187
1.872	1.878	0.563	0.688	2.203	1.000	KWK99187
1.887	1.893	0.551	0.668	2.205	0.984	KWK99189

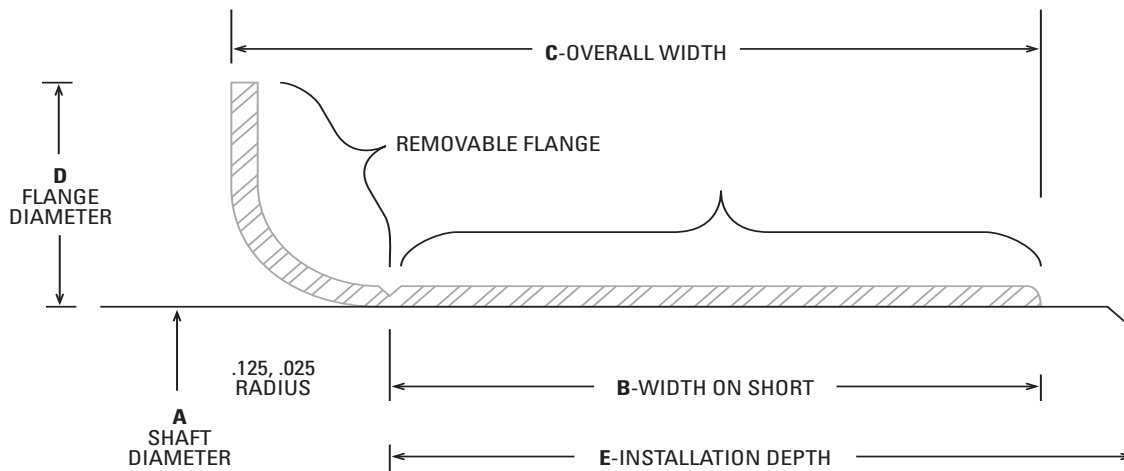

Shaft Diameter Range (A)	Width on Shaft (B)	Overall Width (C)	Flange Diameter (D)	Installation Depth (E)	Part Number
1.909	1.915	0.375	2.219	1.000	KWK99192
1.934	1.940	0.563	2.219	1.000	KWK99193
1.965	1.971	0.551	2.244	0.984	KWK99196
1.977	1.983	0.563	2.313	1.050	KWK99198
1.997	2.003	0.563	2.406	1.000	KWK88199
1.997	2.003	0.563	2.406	1.000	KWK99199
1.997	2.003	0.875	2.406	1.000	KWK99200
2.041	2.047	0.500	2.469	1.000	KWK99204
2.057	2.063	0.781	2.469	1.375	KWK99205
2.123	2.128	0.500	2.422	1.281	KWK99210
2.124	2.130	0.781	2.422	1.375	KWK99212
2.162	2.168	0.787	2.441	1.250	KWK99215
2.186	2.192	0.781	2.500	1.313	KWK88218
2.186	2.192	0.781	2.500	1.313	KWK99218
2.197	2.205	0.500	2.500	1.250	KWK99220
2.227	2.233	0.500	2.531	1.313	KWK99229
2.227	2.233	0.781	2.531	1.250	KWK99230
2.237	2.243	0.764	2.562	1.250	KWK99226
2.249	2.255	0.313	2.531	1.313	KWK99227
2.249	2.255	0.781	2.531	1.313	KWK88225
2.249	2.255	0.781	2.531	1.313	KWK99225
2.309	2.315	0.781	2.688	1.600	KWK99231
2.327	2.333	0.750	2.750	1.610	KWK88233
2.327	2.333	0.750	2.750	1.610	KWK99233
2.359	2.365	0.370	2.783	1.472	KWK99241
2.359	2.365	0.787	2.785	1.375	KWK99235
2.369	2.375	0.781	2.750	1.375	KWK99236
2.372	2.378	0.594	2.750	1.375	KWK99238
2.374	2.380	0.526	2.750	1.375	KWK99240
2.374	2.380	0.781	2.734	1.375	KWK99237

Shaft Diameter Range (A)		Width on Shaft (B)	Overall Width (C)	Flange Diameter (D)	Installation Depth (E)	Part Number
2.434	2.440	0.781	0.938	2.828	1.375	KWK99243
2.435	2.441	0.500	0.626	2.827	1.417	KWK99242
2.489	2.495	0.781	0.938	2.875	1.393	KWK99249
2.497	2.503	0.555	0.650	2.820	0.890	KWK99253
2.500	2.506	0.500	0.656	2.828	1.375	KWK99248
2.500	2.506	0.781	0.938	2.828	1.375	KWK99250
2.510	2.516	0.781	0.906	2.828	1.438	KWK99251
2.556	2.562	0.787	0.905	2.850	1.378	KWK99254
2.560	2.566	0.781	0.938	2.891	1.375	KWK99256
2.595	2.602	0.781	0.938	2.990	1.250	KWK99259
2.618	2.624	0.781	0.938	3.047	1.375	KWK99261
2.621	2.627	0.781	0.906	3.047	1.375	KWK99264
2.622	2.628	0.500	0.625	3.047	1.375	KWK99260
2.625	2.631	0.781	0.938	3.047	1.375	KWK99262
2.727	2.733	0.781	0.906	3.125	1.313	KWK99268
2.740	2.746	0.781	0.938	3.065	1.250	KWK99273
2.745	2.751	0.781	0.938	3.125	1.250	KWK99274
2.747	2.753	0.781	0.906	3.125	1.250	KWK99270
2.747	2.753	1.438	1.625	3.075	1.625	KWK99267
2.750	2.756	0.406	0.563	3.125	1.250	KWK99272
2.750	2.756	0.781	0.938	3.125	1.250	KWK99275
2.750	2.756	1.125	1.250	3.125	1.250	KWK99269
2.753	2.759	0.787	0.945	3.125	1.250	KWK99276
2.809	2.815	0.594	0.688	3.188	1.250	KWK99281
2.838	2.844	0.500	0.656	3.225	1.250	KWK99282
2.866	2.872	0.781	0.938	3.188	1.250	KWK99286
2.873	2.879	0.781	0.938	3.219	1.250	KWK99287
2.937	2.943	0.500	0.641	3.344	1.331	KWK99290
2.937	2.943	0.781	0.938	3.344	1.250	KWK99293
2.950	2.956	0.594	0.689	3.272	1.102	KWK99289
2.950	2.956	0.866	1.024	3.305	1.312	KWK99294
2.972	2.976	0.813	-	-	-	KWK99292
2.990	2.996	0.484	0.625	3.359	1.331	KWK99291
2.990	2.996	0.563	0.688	3.359	1.375	KWK99298
2.990	2.996	0.813	1.000	3.359	1.250	KWK99299
2.997	3.003	0.813	0.938	3.240	1.375	KWK99296
3.000	3.006	0.625	0.813	3.345	1.063	KWK99303
3.000	3.006	0.813	1.000	3.453	1.250	KWK99300
3.008	3.014	0.500	0.625	3.355	2.000	KWK99301
3.120	3.126	0.688	0.813	3.531	2.000	KWK99311
3.120	3.126	0.813	1.000	3.531	2.000	KWK99312
3.124	3.132	0.551	0.709	3.525	2.031	KWK99307
3.142	3.150	0.750	0.886	3.540	1.375	KWK99313
3.146	3.153	0.433	0.590	3.543	1.378	KWK99317
3.146	3.153	0.827	0.945	3.543	1.375	KWK99315
3.225	3.231	0.661	0.850	3.587	1.732	KWK99328
3.247	3.253	0.813	1.000	3.594	1.375	KWK99322
3.248	3.254	0.600	0.725	3.585	1.375	KWK99323
3.250	3.256	0.595	0.719	3.594	1.375	KWK99324
3.250	3.256	0.688	0.875	3.585	1.250	KWK99326

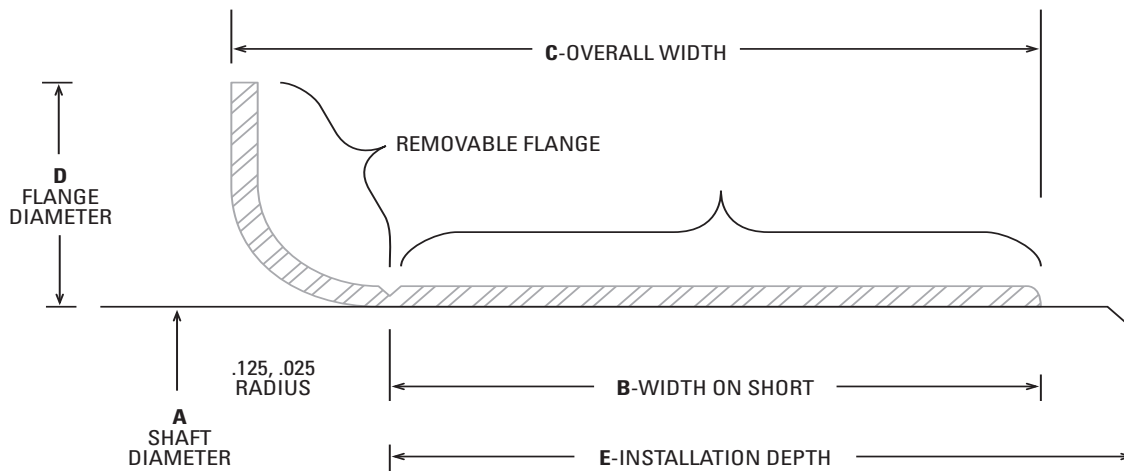

Shaft Diameter Range (A)		Width on Shaft (B)	Overall Width (C)	Flange Diameter (D)	Installation Depth (E)	Part Number
3.250	3.256	0.813	1.000	3.594	1.375	KWK99325
3.307	3.313	0.813	1.000	3.688	1.375	KWK99331
3.337	3.346	0.827	0.984	3.700	1.378	KWK99333
3.338	3.346	0.827	0.984	3.697	1.433	KWK99334
3.373	3.379	0.375	0.500	3.688	1.410	KWK99338
3.373	3.379	0.813	1.000	3.688	1.375	KWK99337
3.435	3.441	0.781	0.906	3.844	1.406	KWK99339
3.477	3.483	0.781	0.906	3.835	1.406	KWK99340
3.500	3.506	0.315	0.500	3.827	1.339	KWK99347
3.500	3.506	0.813	1.000	3.844	1.375	KWK99350
3.501	3.507	0.626	0.811	3.842	1.339	KWK99349
3.540	3.546	0.528	0.665	4.000	1.732	KWK99353
3.540	3.546	0.710	0.906	4.000	1.813	KWK99351
3.540	3.546	0.906	1.102	4.000	1.750	KWK99354
3.560	3.566	0.813	1.000	3.900	1.750	KWK99356
3.618	3.624	0.811	1.000	4.031	1.732	KWK99360
3.623	3.629	0.500	0.625	4.025	1.750	KWK99363
3.623	3.629	0.813	1.000	4.031	1.750	KWK99362
3.684	3.690	0.313	0.438	3.830	0.375	KWK99368
3.685	3.691	0.813	0.938	4.025	1.750	KWK99359
3.685	3.691	0.813	0.938	4.025	1.750	KWK99365
3.737	3.743	0.827	0.945	4.025	1.750	KWK99369
3.740	3.746	0.344	0.500	4.031	1.750	KWK99374
3.740	3.746	0.469	0.594	4.035	1.750	KWK99364
3.746	3.752	0.563	0.688	4.025	1.750	KWK99376
3.750	3.756	0.344	0.500	4.031	1.750	KWK99367
3.750	3.756	0.688	0.875	4.031	1.875	KWK99372
3.873	3.879	0.813	1.000	4.219	1.875	KWK99387
3.935	3.941	0.813	1.000	4.313	1.340	KWK99393
3.998	4.006	0.500	0.625	4.375	2.066	KWK99401

Shaft Diameter Range (A)		Width on Shaft (B)	Overall Width (C)	Flange Diameter (D)	Installation Depth (E)	Part Number
3.998	4.006	0.600	0.725	-	2.050	KWK99395
3.998	4.006	0.650	0.775	4.375	1.375	KWK99400
3.998	4.006	0.813	1.000	4.375	1.250	KWK99399
4.122	4.130	0.813	1.000	4.420	1.375	KWK99412
4.130	4.138	0.787	0.906	4.470	1.378	KWK99413
4.183	4.191	0.813	1.000	4.500	1.375	KWK99418
4.226	4.234	0.781	0.906	4.610	1.438	KWK99423
4.248	4.256	0.813	1.000	4.813	1.375	KWK99424
4.327	4.335	0.509	0.650	4.921	1.250	KWK99435
4.370	4.378	0.813	1.000	4.750	1.650	KWK99437
4.434	4.442	1.000	1.142	4.813	1.313	KWK99439
4.496	4.504	0.813	1.000	5.000	1.375	KWK99450
4.523	4.531	0.813	0.938	5.000	1.250	KWK99452
4.621	4.629	0.438	0.625	5.000	1.375	KWK99465
4.621	4.629	1.000	1.250	5.063	1.375	KWK99463
4.685	4.693	0.812	1.000	5.062	1.375	KWK99468
4.720	4.728	0.787	0.984	5.110	1.260	KWK99473
4.746	4.754	0.500	0.750	5.250	1.500	KWK99475
4.801	4.807	0.787	0.945	5.177	1.260	KWK99472
4.871	4.879	0.625	0.752	5.252	1.457	KWK99487
4.917	4.925	0.394	0.551	5.402	1.457	KWK99490
4.917	4.925	1.024	1.260	5.400	1.438	KWK99492
4.998	5.006	0.688	0.875	5.400	1.438	KWK99498
4.998	5.006	0.813	1.000	5.406	1.500	KWK99499
5.110	5.118	0.750	0.938	5.493	1.181	KWK99494
5.117	5.125	0.866	0.996	5.942	1.299	KWK99491
5.246	5.254	0.813	1.000	5.560	1.250	KWK99525
5.371	5.379	0.813	1.000	5.875	1.250	KWK99537
5.498	5.506	0.812	1.000	5.938	1.250	KWK99549
5.508	5.516	0.807	1.000	5.945	1.250	KWK99552
5.746	5.754	0.813	1.000	6.180	1.750	KWK99575
5.871	5.879	1.000	1.250	6.188	1.313	KWK99587
5.895	5.905	1.024	1.181	6.260	1.338	KWK99595
5.934	5.942	1.000	1.125	6.375	1.875	KWK99596
5.995	6.003	0.500	0.750	6.360	1.750	KWK99601
5.995	6.003	1.000	1.250	6.375	1.750	KWK99599
6.092	6.102	1.024	1.181	6.500	1.299	KWK99606
6.245	6.255	1.031	1.250	6.625	1.750	KWK99625
6.289	6.299	1.000	1.250	7.000	1.800	KWK99630
6.495	6.505	1.000	1.250	7.000	1.750	KWK99650
6.683	6.693	1.250	1.496	7.188	1.750	KWK99640
6.745	6.755	0.813	1.063	7.125	1.750	KWK99675
6.995	7.005	1.000	1.250	7.500	1.750	KWK99700
7.077	7.087	1.300	1.496	7.500	1.752	KWK99721
7.244	7.254	1.250	1.500	7.760	2.175	KWK99725
7.495	7.505	0.813	1.000	7.875	1.250	KWK99750
7.745	7.755	1.000	1.313	8.270	1.875	KWK99775
7.869	7.879	1.359	1.500	8.375	1.750	KWK99787
7.933	7.943	1.000	1.250	8.375	1.750	KWK99799
7.995	8.005	1.000	1.250	8.375	1.750	KWK99800

Shaft	O.D.	Width	Part Number	Seal Number	Description
-	-	-	5068	-	(Split Seal)
-	-	-	5073	-	Contains (2) G753 Gasket
-	-	-	5106	-	Split Seal
-	-	-	5111	-	(Split Seal)
-	-	-	5112	-	(Split Seal)
-	-	-	5118	-	(Split Seal)
-	-	-	5682	-	
-	-	-	5685	-	
-	-	-	5686	-	(Kit)
-	-	-	5690	-	(Repair Kit)
-	-	-	5694	**1884	(Kit)
-	-	-		**4899	
-	-	-		722111	
-	-	-	5700	-	(Kit)
-	3.030	0.325	5092	-	(Split Seal)
-	4.000	0.187	5116	-	(Split Seal)
-	4.200	0.222	5108	-	(Split Seal)
-	4.862	0.410	*5479	-	Contains (2) * G196 Gasket & (2) * G214 Gasket
-	4.875	0.455	5476	**	Contains (2) * G211 Gasket
-	4.875	0.410	5596	-	Contains (2) * G196 Gasket & (2) * G456 Gasket
-	5.625	0.430	5414	-	Contains (2) * G129 Gasket & * G130 Gasket & * G131 Gasket
-	5.700	0.415	*5576	-	Contains (2) * G427 Gasket
-	5.700	0.415	5650	-	
-	6.240	0.400	5591	-	Contains (2) * G462 Gasket & (2) * G463 Gasket
-	6.600	0.430	5390	-	Contains (2) * G214 Gasket & (2) * G594 Gasket
-	6.906	0.440	5419	-	Contains (2) * G137 Gasket
1.062	1.507	0.250	5346	**340210	Contains (2) * 666215 'O' Ring & * 666232 'O' Ring & * 666334 'O' Ring
1.062	2.129	0.625	5168	**413293	Contains * JV1872 Wear Sleeve
1.172	1.832	0.422	5462	**6370N	Contains * J712 Wear Sleeve
1.250	1.756	-	PSK-1	SR2	(KIT)
1.250	1.756	-		**SW2	
1.250	1.756	-		5683	++
1.250	1.756	-		5864	++
1.250	2.254	0.750	5166	**410169	Contains * JV1873 Wear Sleeve
1.376	2.254	1.370	5204	**7495S	Contains * RP 691 Bushing (Seal & Bushing Kit)
1.438	2.192	0.480	5550	**9249	Contains * 623017 'O' Ring
1.493	2.507	0.700	5592	**8097	Contains * JV970 Wear Sleeve
1.500	2.378	1.500	5201	**470059	Contains * RP 605 Bushing (Seal & Bushing Kit)
1.500	2.378	1.500	5202	**7692S	Contains * RP 605 Bushing (Seal & Bushing Kit)
1.500	2.570	0.550	5071	**200861%	Contains * JV933 Wear Sleeve
1.502	2.381	0.940	5200	**9613S	Contains * RP 356 Bushing (Seal & Bushing Kit)
1.562	2.506	0.500	5331	**450185	Contains * G199 Gasket
1.566	2.515	1.370	5207	**8935S	Contains * RP 553 Bushing (Seal & Bushing Kit)
1.688	2.687	1.240	5205	**7038SA	Contains RP 717 Bushing (Seal & Bushing Kit)
1.688	2.850	2.120	5206	**7300S	Contains * RP 546 Bushing (Seal & Bushing Kit)
1.689	2.850	2.120	5203	**7300S	Contains * RP 661 Bushing (Seal & Bushing Kit)
1.750	3.376	0.667	5302	**8398	Contains * K259 Wiper
1.763	2.416	0.563	5000	**	-
1.766	3.005	0.875	5364	**451139	Contains * JX825 Wear Sleeve
1.812	2.879	0.718	5531	**410295	Contains * JV1464 Wear Sleeve

Shaft	O.D.	Width	Part Number	Seal Number	Description
1.875	2.565	0.563	5001	-	
1.875	2.627	0.843	5599	**470455	Contains * J990 Wear Sleeve
1.875	2.690	0.625	5388	450360	Contains * J1107 Wear Sleeve
1.875	2.762	0.500	5336	**410283	Contains * G736 Gasket
1.875	2.808	0.433	5699	4310	Contains * AS232 'O' Ring
1.875	3.130	0.625	5361	**450310N	Contains * J1107 Wear Sleeve
1.875	3.150	0.315	5697	4051	Contains * AS232 'O' Ring
1.875	4.812	0.312	5594	**7105S	Contains (2) * G196 Gasket & (2) * G456 Gasket
1.880	2.414	0.250	5458	**6910S	Contains * 610101 'O' Ring
1.887	1.998	1.000	5208	**9449	Contains RP775 Bushing (Seal & Bushing Kit)
1.915	2.548	0.250	5499	**7020	Contains * 610105 'O' Ring
1.915	2.548	0.250	5573	**7020	Contains * 610145 'O' Ring
2.000	3.376	0.625	5161	**410972	Contains * J1109 Wear Sleeve & * JV1837 Wear Sleeve
2.000	3.376	0.625	5188	**410972N	Contains * J1109 Wear Sleeve & * JV1837 Wear Sleeve
2.000	4.562	0.562	5329	6465B	Contains (2) G33 Gasket
2.000	4.562	0.562	5330	**6469	Contains (2) * G34 Gasket
2.000	5.880	0.458	*5172	**6959	Contains * K251 Wiper & * G895A Gasket
2.000	5.880	0.448	5487	-	Contains (2) * G221 Gasket & * K251 Wiper
2.010	2.965	0.318	5695	**SK1	Contains *SK3 Wear Sleeve (Kit)
2.010	2.965	0.318		**SK2	
2.047	2.964	0.315	5696	**1993	(Kit)
2.047	2.964	0.315		**4898	
2.047	2.964	0.315		722110	
2.120	3.505	0.750	5521	**415093	Contains * JV1456 Wear Sleeve
2.121	3.350	0.500	5397	**9434	
2.121	3.350	0.500		**482435	
2.125	3.072	0.433	5604	**3948	Contains * JV2019 Wear Sleeve
2.129	2.766	0.250	5488	**6957	Contains * 610123 'O' Ring
2.129	2.766	0.250	5589	**6957	Contains * 666151 'O' Ring
2.187	3.194	0.437	5332	450354	Contains * G25 Gasket
2.250	3.256	0.625	5160	**412038	Contains * J1113 Wear Sleeve & * JV1836 Wear Sleeve
2.250	3.256	0.625	5189	**412038N	Contains * J1113 Wear Sleeve & * JV1836 Wear Sleeve
2.340	3.355	0.650	5666	**3501V	Contains * JX1966 Wear Sleeve
2.375	3.433	1.000	5602	**473274N	Contains * JV1802 Wear Sleeve
2.375	4.943	1.000	5603	**3136N	Contains * JV1802 Wear Sleeve
2.377	3.505	0.937	5066	**3894V	Contains * JX1920 Wear Sleeve Seal & Sleeve
2.420	3.558	0.336	5698	4185	Contains * AS043 'O' Ring
2.430	3.031	0.380	5567	-	
2.432	3.756	0.750	*5520	**415244	Contains * JV1455 Wear Sleeve
2.496	3.758	0.625	5045	**200851%	Contains * JV1582 Wear Sleeve
2.500	6.125	0.435	5401	**7512S	Contains (2) * G41 Gasket & * G43 Gasket & * JV1304 Wear Sleeve
2.531	6.125	0.500	5384	**7154S	Contains & G41 Gasket
2.562	8.250	1.003	5406	**6481N	Contains * G40 Gasket & * K282 Wiper
2.625	3.480	0.380	5072	-	
2.625	3.755	0.625	5147	**200919	Contains * JV1517 Wear Sleeve
2.750	3.881	1.000	5584	**415479N	Contains * K198 Wiper
2.812	4.504	1.000	5399	**415356	Contains * JV1427 Wear Sleeve
2.835	3.425	0.230	5163	-	
2.860	6.562	0.571	5403	**6479	Contains J493 Wear Sleeve
2.875	3.756	0.625	5601	**476023N	Contains * JV1120 Wear Sleeve

Shaft	O.D.	Width	Part Number	Seal Number	Description
2.988	3.740	1.165	5290	** -	
2.991	3.637	0.385	5273	**100202T	(Tefbnf)
3.000	4.008	0.625	5629	**457034	Contains * J1121 Wear Sleeve
3.000	4.008	0.687	5657	**457034	Contains * JX1747 Wear Sleeve
3.000	8.250	0.531	5452	6764S	Contains * G48 Gasket & * G167 Gasket & * J495 Wear Sleeve
3.010	8.150	0.925	5494	**6897	Contains (2) * G40 Gasket & * K156 Wiper
3.010	8.250	0.571	5015	**8369S	Contains * G48 Gasket & * JV495 Wear Sleeve & (2) * G523 Gasket
3.010	8.250	0.571	5313	**8369S	Contains * K282 Wiper & (2) * G523 Gasket
3.110	5.750	0.375	5079	**7896S	
3.112	4.633	0.920	5100	**9583	Contains * JV1508 Wear Sleeve
3.119	4.130	0.750	5509	**255566H	Contains * J1401 Wear Sleeve
3.119	4.756	0.875	5518	-	
3.124	8.250	0.518	5408	**6477S	Contains (2) * G40 Gasket & * G42 Gasket & * J873 Wear Sleeve
3.125	4.130	0.625	5120	**415566N	Contains * J1122 Wear Sleeve
3.125	4.130	1.000	5578	**485500N	Contains * K179 Wiper
3.125	7.500	0.625	5405	**6480	Contains * G49 Gasket & * K282 Wiper
3.125	8.125	0.571	5410	**6505S	Contains * G48 Gasket & (2) * G54 Gasket & * JV495 Wear Sleeve
3.125	8.250	0.571	5185	-	
3.250	4.008	0.866	5609	-	
3.250	4.254	0.750	5169	**476028	Contains * JV1875 Wear Sleeve
3.250	4.254	0.625	5373	**416294N	Contains * J1123 Wear Sleeve
3.250	4.254	0.625	5382	**415613	Contains * J1123 Wear Sleeve
3.250	4.572	0.750	5593	**200870	Contains * JV980 Wear Sleeve
3.250	5.004	0.625	5381	**415025	Contains * J1123 Wear Sleeve
3.375	4.380	0.812	5588	**8130	Contains * JV976 Wear Sleeve
3.438	4.012	0.410	5095	-	(Rope Type)
3.438	4.313	0.188	5117	-	(Split Seal)
3.465	4.266	0.437	5287	**100239T	Contains 732079 Gasket & * 733419 Gasket & 734280 Gasket (Tefbnf)
3.500	5.256	0.718	*5551	**416335	Contains * JV1494 Wear Sleeve
3.500	6.625	0.531	5327	**6245S	Contains (2) * G35 Gasket
3.562	4.630	0.700	5347	**8480	Contains * JV1170 Wear Sleeve
3.562	5.125	0.875	5649	**9584	Contains * JV1509 Wear Sleeve
3.562	5.256	0.468	5532	**416670	Contains * JV1469 Wear Sleeve
3.583	4.375	0.394	5279	**100052T	Contains 731414 Gasket (Tefbn f)
3.625	4.256	0.390	5277	**100204T	(Tefbnf)
3.625	4.756	0.875	5167	**475379	Contains * JV1874 Wear Sleeve
3.625	4.879	0.585	5453	**485497	Contains * 633013 'O' Ring Kit
3.740	4.540	0.492	5274	**100203T	Contains 733215 Gasket (Tefbn
3.750	4.506	0.362	5278	**100205T	(Tefbnf)
3.750	4.756	0.625	5084	-	
3.865	6.102	0.975	5667	**4269	Contains * J2058 Wear Sleeve
3.868	5.506	0.921	5475	**6864S	Contains * J718 Wear Sleeve
3.930	5.381	0.875	5028	**9586	Contains * JV1511A Wear Sleeve
3.937	5.506	0.859	5465	**455037	Contains * JV1362 Wear Sleeve
3.937	5.506	0.859	5563	**6864S	Contains * JV1362 Wear Sleeve
3.937	5.509	0.597	5089	**2155	Contains * JV1511 Wear Sleeve
3.937	5.678	0.875	5076	**9586	Contains * JV1511 Wear Sleeve
3.994	5.004	0.718	5526	**415134	Contains * JV1461 Wear Sleeve
3.994	5.005	0.625	5065	**455134H	Contains * J1129 Wear Sleeve
4.000	5.004	0.625	5376	**413134N	Contains * J1129 Wear Sleeve

Shaft	O.D.	Width	Part Number	Seal Number	Description
4.000	5.004	0.937	5581	**7390	Contains * JV943 Wear Sleeve
4.062	5.506	0.875	5170	**415039	Contains * JV1473 Wear Sleeve
4.062	6.000	0.875	5537	**416673	Contains * JV1473 Wear Sleeve
4.375	6.259	0.843	5077	**9587	Contains * JV1512 Wear Sleeve
4.500	6.259	0.862	5075	**9588	Contains * JV1513 Wear Sleeve
4.642	5.756	0.750	5008	455053	Contains * JX847 Wear Sleeve
4.646	5.756	0.625	5625	**485138	Contains * JX1386 Wear Sleeve
4.687	5.756	1.562	5460	**455251H	Contains * JV729 Wear Sleeve
4.687	5.756	1.562	5461	**75251S	Contains * J729 Wear Sleeve
4.687	7.635	0.359	5575	**6701	Contains JV608 Wear Sleeve
4.743	6.256	0.812	5527	415068	Contains * JV1462 Wear Sleeve
4.750	6.006	0.750	*5010	**476621H	Contains * J1135 Wear Sleeve
4.750	6.256	0.750	5377	**415068N	Contains * J1135 Wear Sleeve
4.759	6.316	1.250	5481	**6872S	Contains * JV753 Wear Sleeve
4.759	6.505	1.125	5483	**6873S	Contains * JV753 Wear Sleeve
4.759	7.004	1.250	5495	**7006S	Contains * JV753 Wear Sleeve
4.812	6.316	1.250	5471	**6872S	Contains * JV701 Wear Sleeve
4.812	6.505	1.125	5473	**6873S	Contains * JV701 Wear Sleeve
4.812	7.004	1.250	5472	**7006S	Contains * JV701 Wear Sleeve
4.834	5.756	0.710	5033	**3492	Contains * JX2162 Wear Sleeve
4.841	5.756	0.750	5665	**3492V	Contains JX1967 Wear Sleeve
4.875	6.006	0.715	5643	**3782	Contains * J1606 Wear Sleeve
4.993	6.131	0.750	5229	**416172	Contains * J1137 Wear Sleeve
5.000	6.006	0.717	5722	**947090	Contains * JL2370 Wear Sleeve
5.000	6.131	0.875	5199	**8971H	Contains * JX1831 Wear Sleeve
5.000	6.131	0.875	5624	**456557	Contains * JX1831 Wear Sleeve
5.179	6.513	1.380	5424	**327984	Contains * JF2280 Wear Sleeve
5.180	6.507	0.750	*5082	**456986H	Contains * J2037 Wear Sleeve
5.187	6.513	1.380	5422	**327984	Contains * JF2280 Wear Sleeve
5.500	6.631	0.875	5146	**415487	Contains * JV1463 Wear Sleeve
5.625	6.632	1.000	5383	455447	Contains * J1355 Wear Sleeve
5.875	7.008	0.875	5228	**456055V	Contains * JX1002 Wear Sleeve
5.991	6.757	0.500	5039	**4165V	Contains * JV2088 Wear Sleeve
5.998	6.757	0.675	5645	**4165V	Contains * J2051 Wear Sleeve
6.000	6.757	0.750	5026	**336665H	Contains * J1141 Wear Sleeve
6.079	7.336	0.750	5613	**2628	Contains * K458 Wiper & * J1842 Wear Sleeve
6.079	7.336	0.600	5637	**2628	Contains * J1895 Wear Sleeve
6.204	7.336	0.812	*5634	**3807	Contains * J1825 Wear Sleeve
6.500	8.007	0.750	5436	914414	Contains JG2361 Wear Sleeve
6.500	8.007	0.750	5441	914411	Contains JL2361 Wear Sleeve
6.500	8.007	1.000	5443	914413	Contains JG2345 Wear Sleeve
6.875	8.382	0.750	5538	**416674	Contains * JV1474 Wear Sleeve
6.875	8.633	0.825	5164	**3123	
6.875	8.633	0.825		**3124	
7.369	9.010	0.875	5276	**415551	Contains * JV1190 Wear Sleeve
7.908	9.508	0.960	5615	**3624	
7.908	9.508	0.960		**3776S	
9.057	10.719	1.000	5632	**3689	Contains * J1984 Wear Sleeve
9.265	11.385	0.990	5175	**455871V	Contains * JV829 Wear Sleeve
9.375	11.383	0.825	5227	**3502	
9.375	11.383	0.825		**3503	

Part Number	Style	Matl	Shaft	Bore	O.D.	Width	Part Number	Style	Matl	Shaft	Bore	O.D.	Width
◆1012N	320	S	1.772 45	2.441 62	2.452 62.28	0.315 8	◆1168←	320	S	1.299 33	1.969 50	1.978 50.25	0.472 12
◆1012S	350	S	1.772 45	2.441 62	2.452 62.28	0.315 8	◆1170	320	S	1.378 35	2.047 52	2.057 52.25	0.394 10
◆1015	350	S	0.709 18	1.102 28	1.111 28.22	0.236 6	◆1170S	320	S	1.378 35	2.047 52	2.057 52.25	0.394 10
◆1015N	350	S	0.709 18	1.102 28	1.111 28.22	0.236 6	◆1172→	320	H	1.378 35	1.850 47	1.866 47.40	0.276 7
◆1019←	320	H	2.992 76	3.661 93	3.673 93.30	0.394 10	◆1172S→	320	H	1.378 35	1.850 47	1.866 47.40	0.276 7
◆1019S←	320	H	2.992 76	3.661 93	3.673 93.30	0.394 10	◆1173	320	N	1.378 35	2.638 67	2.648 67.27	0.472 12
◆1021←	320	V	2.756 70	3.425 87	3.436 87.27	0.335 8.50	◆1174	320	S	1.496 38	2.047 52	2.058 52.27	0.276 7
◆1021V←	320	V	2.756 70	3.425 87	3.436 87.27	0.335 8.50	◆1174S	320	S	1.496 38	2.047 52	2.058 52.27	0.276 7
◆1036→	400	N	1.575 40	2.992 76	3.003 76.28	0.354 9	◆1175	320	S	1.496 38	2.283 58	2.294 58.27	0.433 11
1037	350	S	1.125	1.500	1.504	0.250	◆1176→	#	N	1.496 38	2.559 65	2.570 65.27	0.472 12
◆1038→	320	N	1.496 38	2.323 59	2.334 59.28	0.354 9	◆1176S→	#	N	1.496 38	2.559 65	2.570 65.27	0.472 12
◆1039S	350	S	2.362 60	3.150 80	3.161 80.29	0.315 8	◆1177	320	N	1.496 38	2.913 74	2.920 74.17	0.433 11
1041	480	S	0.500	1.003	1.009	0.250	◆1178	320	S	1.575 40	2.047 52	2.057 52.25	0.236 6
1049	330	S	0.750	1.125	1.131	0.189	◆1178S	320	S	1.575 40	2.047 52	2.057 52.25	0.236 6
1097	330	S	1.375	1.947	1.953	0.500	◆1180	320	S	1.614 41	2.165 55	2.172 55.17	0.236 6
1097N	330	S	1.375	1.947	1.953	0.500	◆1180S	320	S	1.614 41	2.165 55	2.172 55.17	0.236 6
◆1108→	320	V	1.378 35	1.890 48	1.899 48.24	0.394 10	◆1181	350	S	1.614 41	2.205 56	2.211 56.16	0.276 7
1110	#	F	1.400	1.969	2.000	0.250	◆1183	340	S	1.693 43	2.165 55	2.176 55.27	0.315 8
◆1120←	320	V	1.496 38	2.087 53	2.098 53.29	0.276 7	◆1187S	320	S	1.850 47	2.677 68	2.688 68.27	0.394 10
◆1120S←	320	V	1.496 38	2.087 53	2.098 53.29	0.276 7	◆1188	340	S	1.890 48	2.441 62	2.452 62.28	0.236 6
◆1121←	320	V	1.220 31	1.811 46	1.820 46.23	0.315 8	◆1188S	340	S	1.890 48	2.441 62	2.452 62.28	0.236 6
◆1126	250	S	1.535 39	1.984 50.40	1.991 50.57	0.335 8.50	1192	320	S	1.605	2.374	2.386	0.375
◆1126S	250	S	1.535 39	1.984 50.40	1.991 50.57	0.335 8.50	◆1195	320	S	1.562	2.061	2.275	0.338
1128S	350	S	1.535	2.000	2.008	0.295	◆1196	470	S	1.496 38	2.047 52	2.058 52.27	0.236 6
◆1129	350	S	1.181 30	1.575 40	1.584 40.23	0.276 7	◆1205	470	S	1.535 39	2.047 52	2.053 52.15	0.248 6.30
◆1136←	300	N	1.378 35	2.992 76	3.003 76.28	0.354 9	◆1205N	470	S	1.535 39	2.047 52	2.053 52.15	0.248 6.30
◆1136S←	300	N	1.378 35	2.992 76	3.003 76.28	0.354 9	◆1207	490	S	2.165 55	2.913 74	2.920 74.17	0.236 6
◆1140→	320	N	1.378 35	2.677 68	2.688 68.28	0.354 9	◆1207N	490	S	2.165 55	2.913 74	2.920 74.17	0.236 6
◆1146←	320	N	1.575 40	2.992 76	3.003 76.28	0.354 9	1208	320	S	1.890	2.835	2.847	0.276
◆1146S←	320	N	1.575 40	2.992 76	3.003 76.28	0.354 9	1208S	320	S	1.890	2.835	2.847	0.276
◆1147→	320	N	1.378 35	2.992 76	3.003 76.28	0.354 9	◆1209	350	S	1.969 50	2.559 65	2.565 65.15	0.354 9
◆1167	320	N	1.260 32	2.047 52	2.058 52.27	0.433 11							
◆1167S	320	N	1.260 32	2.047 52	2.058 52.27	0.433 11							

Part Number	Style	Matl	Shaft	Bore	O.D.	Width	Part Number	Style	Matl	Shaft	Bore	O.D.	Width
◆1209S	350	S	1.969 50	2.559 65	2.565 65.15	0.354 9	1952	540	S	1.771	3.661	3.661	0.313
◆1213	470	S	1.575 40	2.126 54	2.132 54.15	0.209 5.30	◆1953	320	N	1.654 42	2.362 60	2.373 60.27	0.276 7
◆1213N	470	S	1.575 40	2.126 54	2.132 54.15	0.209 5.30	◆1953S	320	N	1.654 42	2.362 60	2.373 60.27	0.276 7
◆1213S	470	S	1.575 40	2.126 54	2.132 54.15	0.209 5.30	◆1955	350	S	2.047 52	2.559 65	2.565 65.15	0.354 9
◆1214	470	S	1.654 42	2.165 55	2.172 55.17	0.354 9	◆1956	#	S	1.890 48	2.441 62	2.452 62.28	0.354 9
◆1214N	470	S	1.654 42	2.165 55	2.172 55.17	0.354 9	◆1956S	#	S	1.890 48	2.441 62	2.452 62.28	0.354 9
◆1215←	#	N	1.378 35	1.890 48	1.895 48.13	0.512 13	◆1958	350	S	2.165 55	3.228 82	3.235 82.17	0.394 10
◆1215N←	#	N	1.378 35	1.890 48	1.895 48.13	0.512 13	1959	320	S	1.870	2.781	2.792	0.359
◆1216	740	N	1.575 40	2.520 64	2.526 64.16	0.472 12	◆1960	470	S	1.969 50	2.756 70	2.761 70.13	0.354 9
◆1216N	740	N	1.575 40	2.520 64	2.526 64.16	0.472 12	◆1962	780	S	1.575 40	2.047 52	2.053 52.15	0.276 7
◆1217	350	N	1.575 40	2.047 52	2.053 52.15	0.276 7	◆1963	350	N	0.866 22	1.575 40	1.581 40.16	0.276 7
◆1873→	350	S	1.563 40	2.311 58.70	2.322 58.98	0.374 9.50	◆1964	470	S	2.244 57	2.835 72	2.840 72.14	0.331 8.40
◆1883	320	S	2.047 52	2.638 67	2.649 67.29	0.276 7	◆1965	480	V	1.417 36	2.362 60	2.370 60.20	0.315 8
◆1884	320	S	2.047 52	2.677 68	2.683 68.15	0.295 7.50	◆1966→	350	Y	1.496 38	2.047 52	2.058 52.27	0.276 7
1906	310	S	1.763	2.126	2.134	0.382	1969	470	S	1.890	2.480	2.484	0.354
◆1928	470	S	2.244 57	3.189 81	3.196 81.18	0.315 8	◆1970	350	S	1.181 30	1.654 42	1.663 42.24	0.276 7
◆1932	490	S	2.205 56	2.677 68	2.683 68.15	0.177 4.50	1971	470	S	1.969	2.520	2.524	0.256
◆1932S	490	S	2.205 56	2.677 68	2.683 68.15	0.177 4.50	◆1973	250	S	1.890 48	2.559 65	2.565 65.15	0.319 8.10
◆1935	470	S	2.480 63	3.543 90	3.550 90.17	0.276 7	◆1974	970	S	1.969 50	2.638 67	2.649 67.29	0.433 11
◆1936	#	S	1.929 49	2.520 64	2.531 64.29	0.236 6	◆1975	320	S	2.047 52	2.480 63	2.489 63.23	0.315 8
◆1937	#	S	1.850 47	2.520 64	2.531 64.29	0.236 6	◆1975S	320	S	2.047 52	2.480 63	2.489 63.23	0.315 8
◆1938	#	S	1.772 45	2.520 64	2.531 64.29	0.354 9	◆1979→	470	N	1.772 45	2.953 75	2.959 75.16	0.472 12
◆1939	#	S	1.772 45	2.520 64	2.531 64.29	0.354 9	◆1980→	320	H	1.378 35	1.969 50	1.980 50.29	0.276 7
◆1940→	320	N	1.378 35	1.949 49.50	1.962 49.83	0.394 10	◆1981→	350	N	1.181 30	1.772 45	1.781 45.24	0.315 8
◆1941	470	S	1.988 51	3.051 77.50	3.057 77.65	0.551 14	◆1984	250	S	2.244 57	2.638 67	2.649 67.29	0.236 6
◆1943	440	S	1.772 45	2.843 72.20	2.854 72.49	0.295 7.50	◆1985	480	S	2.362 60	3.543 90	3.550 90.17	0.551 14
1945←	320	H	3.228	4.134	4.146	0.512	◆1985S	480	S	2.362 60	3.543 90	3.550 90.17	0.551 14
◆1948	350	S	1.969 50	2.677 68	2.688 68.28	0.315 8	◆1986	480	S	2.835 72	3.465 88	3.474 88.25	0.276 7
1949	480	S	1.875	2.441	2.447	0.325	◆1986S	480	S	2.835 72	3.465 88	3.474 88.25	0.276 7
◆1950	410	S	1.614 41	2.087 53	2.093 53.16	0.276 7	1987	330	N	1.375	1.937	1.954	0.235
◆1951	870	S	1.772 45	2.520 64	2.531 64.29	0.354 9	◆1987S	330	N	1.375	1.937	1.954	0.235
							1989	470	S	1.126	1.693	1.699	0.256
							◆1990→	320	N	1.063 27	1.693 43	1.702 43.23	0.354 9

Part Number	Style	Matl	Shaft	Bore	O.D.	Width	Part Number	Style	Matl	Shaft	Bore	O.D.	Width
◆1992	470	S	1.772 45	2.559 65	2.565 65.15	0.197 5	◆2261←	470	V	4.331 110	5.118 130	5.132 130.35	0.394 10
◆1993	470	S	2.205 56	2.874 73	2.880 73.15	0.295 7.50	2286	740	S	2.199	3.519	3.523	0.590
◆1994	320	S	1.890 48	2.756 70	2.767 70.28	0.354 9	2287	2740	S	0.750	1.250	1.254	0.280
1999	480	S	1.625	2.250	2.256	0.311	2297V←	250	V	6.000	6.750	6.757	0.500
◆2001←	320	S	2.362 60	3.228 82	3.239 82.27	0.472 12	2300	#	S	1.318	2.620	2.625	1.000
◆2002	470	S	2.126 54	2.559 65	2.565 65.15	0.512 13	2377	350	V	3.750	4.501	4.506	0.362
◆2003	470	S	1.417 36	2.165 55	2.169 55.09	0.256 6.50	◆2440	690	N	1.772 45	2.362 60	2.372 60.25	0.425 10.80
◆2003N	470	S	1.417 36	2.165 55	2.169 55.09	0.256 6.50	2443	250	N	1.375	1.952	1.953	0.500
◆2004	#	S	0.551 14	0.945 24	0.952 24.17	0.500 12.70	2457←	#	N	2.125	2.880	2.885	0.550
◆2007→	#	S	1.378 35	2.205 56	2.216 56.29	0.315 8	2465	#	S	1.687	2.500	2.511	1.535
◆2007N→	#	S	1.378 35	2.205 56	2.216 56.29	0.315 8	2503→	480	N	1.100	1.572	1.578	0.308
◆2007S→	#	S	1.378 35	2.205 56	2.216 56.29	0.315 8	2503N→	480	N	1.100	1.572	1.578	0.308
◆2008	#	S	1.260 32	2.126 54	2.132 54.15	0.354 9	2505	890	S	4.625	6.186	6.192	1.250
◆2008S	#	S	1.260 32	2.126 54	2.132 54.15	0.354 9	2506←	790	S	1.563	2.372	2.378	0.335
◆2009	#	N	1.496 38	2.480 63	2.487 63.17	0.394 10	2628	640	H	6.204	7.328	7.336	0.562
◆2009S	#	N	1.496 38	2.480 63	2.487 63.17	0.394 10	2655←	790	N	1.374	2.244	2.250	0.374
◆2011→	400	N	1.575 40	2.953 75	2.959 75.16	0.472 12	2658	750	H	1.614	2.435	2.441	0.300
◆2011S→	400	N	1.575 40	2.953 75	2.959 75.16	0.472 12	2674	890	S	2.874	4.174	4.181	0.374
◆2012→	320	Y	1.673 43	2.165 55	2.176 55.27	0.236 6	2689S↔	250	S	1.875	2.868	2.879	0.551
◆2012S→	320	Y	1.693 43	2.165 55	2.176 55.27	0.236 6	2692→	760	N	1.876	2.561	2.567	0.528
◆2012V→	320	V	1.693 43	2.165 55	2.176 55.27	0.236 6	2791	330	S	9.000	10.376	10.384	0.625
◆2016	#	S	1.181 30	1.772 45	1.780 45.20	0.591 15	2792	330	S	9.910	10.997	11.005	0.625
◆2025	320	V	1.654 42	2.362 60	2.373 60.27	0.276 7	2822V	410	V	2.062	3.000	3.005	0.375
◆2027	350	S	0.591 15	0.945 24	0.953 24.20	0.276 7	2942	470	N	1.875	2.560	2.565	0.406
2043→	470	S	1.940	2.762	2.768	0.500	2955→	710	N	1.709	2.209	2.215	0.354
2055	470	S	3.468	4.626	4.631	0.625	3016	450	S	5.875	8.001	8.007	0.750
2064	330	S	1.000	1.375	1.381	0.189	◆3051→	330	H	1.654 42	2.165 55	2.176 55.27	0.315 8
2081↔	410	S	2.844	3.938	3.945	0.500	◆3051N→	330	H	1.654 42	2.165 55	2.176 55.27	0.315 8
2146↔	#	S	1.687	2.557	2.568	0.464	3054	410	H	5.500	6.625	6.632	0.670
2194←	880	N	1.500	2.372	2.376	0.420	3083	480	H	1.650	2.282	2.336	0.768
2207	2900	S	1.815	2.562	2.566	0.562	3087	2810	S	2.048	2.728	2.734	0.250
2218	470	H	3.750	4.751	4.756	0.500	3095	690	S	2.240	3.190	3.194	0.450
2222	2860	S	2.750	3.772	3.779	0.311	3100	890	S	4.750	6.186	6.192	1.250
2260	480	V	3.125	3.936	3.943	0.512	3103→	690	S	2.188	3.188	3.199	0.618
							3116←	710	N	1.375	2.374	2.378	0.500
							3116N←	710	N	1.375	2.374	2.378	0.500
							3136N	470	N	2.500	4.938	4.943	0.500
							3143N	740	N	3.000	5.500	5.506	0.531
							3173↔	480	N	1.937	2.686	2.697	0.311
							3186		S	1.875	3.150	3.146	0.930
							3195	590	S	1.875	3.150	3.146	0.930
							3199	480	S	1.250	1.955	1.960	0.256
							3199S	480	S	1.250	1.955	1.960	0.256
							3210	490	S	2.437	3.624	3.628	0.375
							3214↔	480	S	1.365	1.955	1.961	0.438
							3227→	830	N	1.748	2.623	2.629	0.313
							3292	890	S	5.375	6.875	6.882	1.000

Part Number	Style	Matl	Shaft	Bore	O.D.	Width	Part Number	Style	Matl	Shaft	Bore	O.D.	Width
3341	1000	H	4.812	5.544	5.552	0.535	3783	650	H	2.875	3.623	3.628	0.500
3348	470	S	1.299	2.044	2.050	0.490	3783H	650	H	2.875	3.623	3.628	0.500
◆ 3357	2830	S	1.496 38	2.047 52	2.053 52.15	0.236 6	3794	490	S	2.010	2.650	2.655	0.363
3385	740	S	3.180	4.180	4.185	0.750	3807	640	H	6.328	7.329	7.336	0.500
◆ 3392	470	S	1.575 40	2.165 55	2.172 55.17	0.315 8	3813	640	H	2.625	3.695	3.700	0.500
3393 ←	320	V	2.375	3.002	3.013	0.437	◆ 3816	2710	S	0.709 18	1.181 30	1.185 30.10	0.264 6.70
3395 ↔	470	S	1.437	2.062	2.068	0.311	3893V	450	V	3.750	4.750	4.756	0.500
3404	750	H	1.996	2.743	2.751	0.325	3894V	480	V	2.500	3.499	3.505	0.500
◆ 3459 ↔	740	N	1.575 40	2.283 58	2.290 58.17	0.354 9	3896 →	760	S	1.941	2.909	2.915	0.370
◆ 3459S ↔	740	N	1.575 40	2.283 58	2.290 58.17	0.354 9	3905	760	N	3.000	4.938	4.943	0.740
◆ 3476 →	320	N	1.260 32	1.850 47	1.859 47.22	0.315 8	◆ 3907	570	N	1.181 30	2.283 58	2.287 58.09	0.374 9.50
◆ 3476S →	320	N	1.260 32	1.850 47	1.859 47.22	0.315 8	3909 ←	350	V	3.625	4.240	4.251	0.390
3492V	480	V	5.000	5.751	5.756	0.500	3942	2840	S	2.500	3.226	3.231	0.190
3543	570	H	1.378	2.162	2.167	0.575	3945	480	N	2.328	3.000	3.006	0.375
3553	2840	S	2.201	2.735	2.741	0.197	3946	860	S	2.328	3.000	3.006	0.375
3583	830	H	1.748	3.229	3.236	0.335	4019N	470	N	2.432	3.070	3.075	0.227
3583S	830	H	1.748	3.229	3.236	0.335	4040R ←	#	N	1.378	2.097	2.105	0.305
3591	900	N	2.750	5.501	5.506	1.266	◆ 4052R ↔	#	N	1.378 35	2.047 52	2.052 52.13	0.315 8
3592	900	N	3.000	5.501	5.506	1.266	4072 →	830	N	1.787	3.229	3.240	0.335
3604 →	860	V	1.812	2.777	2.781	0.575	4072N →	830	N	1.787	3.229	3.240	0.335
3606	70S	N	1.850	69.000	2.717	0.398	4099	2870	S	1.673	2.162	2.168	0.285
3618	860	S	1.812	2.623	2.627	0.455	4122	470	S	2.881	3.429	3.436	0.291
3622	740	S	1.654	2.518	2.525	0.394	4131	2870	S	2.312	3.000	3.004	0.375
3622S	740	S	1.654	2.518	2.525	0.394	4141	#	N	1.574	2.676	2.683	0.500
3638 →	480	N	1.125	1.624	1.628	0.190	4143	#	N	1.625	2.415	2.440	0.500
◆ 3655 →	320	N	1.378 35	2.047 52	2.058 52.27	0.315 8	4148	2860	S	2.000	2.623	2.629	0.260
◆ 3655S →	320	N	1.378 35	2.047 52	2.058 52.27	0.315 8	4160	2810	S	2.420	3.000	3.006	0.394
3667	2710	S	0.690	0.997	1.003	0.295	◆ 4175	#	S	1.575 40	2.047 52	2.055 52.20	0.354 9
3677	2870	S	1.500	1.989	1.995	0.250	4189H	750	H	1.996	3.111	3.120	0.344
3698 ←	320	H	2.988	3.740	3.751	0.315	4244	720	S	1.552	2.750	2.755	0.590
3698	320	H	2.988	3.740	3.751	0.315	4249	2870	S	1.809	2.361	2.366	0.370
3700	860	S	1.812	3.000	3.005	0.500	4250 ↔	740	S	2.500	3.297	3.304	0.327
◆ 3723	660	S	2.165 55	2.756 70	2.761 70.13	0.354 9	4278	860	V	1.812	3.091	3.097	0.485
3732S	480	S	1.062	1.575	1.581	0.250	4291V	#	V	4.375	5.375	5.425	0.500
◆ 3743	660	S	1.969 50	2.559 65	2.565 65.15	0.354 9	◆ 4307V ←	320	V	2.992 76	3.622 92	3.633 92.28	0.394 10
3747 ↔	690	S	1.705	3.084	3.090	0.461	4333N	790	N	1.886	2.699	2.704	0.350
◆ 3771 →	350	H	1.378 35	1.969 50	1.980 50.29	0.276 7	4353	#	V	7.375	9.615	9.622	0.979
◆ 3772 ←	350	H	3.465 88	4.252 108	4.263 108.28	0.433 11	4353V	#	V	7.375	9.615	9.622	0.979
◆ 3774S →	350	H	1.654 42	2.205 56	2.218 56.34	0.276 7	4359V ←	320	V	3.740	4.525	4.536	0.492
◆ 3774 →	350	H	1.654 42	2.205 56	2.218 56.34	0.276 7	4370N ←	880	N	1.503	2.376	2.383	0.420
							4458V	#	V	0.984	1.499	1.504	0.250
							4503N ↔	790	N	1.886	2.750	2.765	1.375
							4525V	720	V	2.500	4.035	4.040	0.634
							◆ 4528N	660	N	1.890 48	2.559 65	2.565 65.15	0.965 24.50
							4529N →	680	N	1.375	2.047	2.052	0.330

Part Number	Style	Matl	Shaft	Bore	O.D.	Width	Part Number	Style	Matl	Shaft	Bore	O.D.	Width
4530←	960	N	1.502	2.126	2.132	0.492	5121	2810	S	1.938	2.622	2.628	0.266
4532N	930	N	1.375	3.542	3.549	0.397	5123	2800	S	2.560	3.090	3.095	0.256
4539H	750	H	2.367	3.366	3.374	0.257	5124	480	S	1.328	2.227	2.233	0.313
4543V→	#	V	3.250	4.249	4.260	0.662	5126→	740	S	1.875	2.813	2.817	0.500
4544V→	#	V	3.253	5.500	5.511	0.630	5128N	320	N	3.375	3.948	3.955	0.375
4561V←	#	V	2.503	3.428	3.239	0.709	5131	#	S	1.318	2.280	2.285	0.354
4562V→	#	V	3.003	4.937	4.948	0.662	5133	480	V	1.812	2.562	2.566	0.312
4563V	#	V	2.938	3.937	3.947	0.552	5210	350	N	1.299	3.539	3.528	1.575
4564V	#	V	2.748	3.876	3.886	0.552	5711	410	S	1.750	2.983	2.987	0.438
4583←	860	N	1.502	2.377	2.381	0.500	5711S	410	S	1.750	2.983	2.987	0.438
4598→	830	N	1.998	2.878	2.882	0.340	5727	2050	F	1.625	2.722	2.727	0.406
4613N↔	570	N	1.377	2.874	2.881	0.693	5751	340	S	3.125	4.562	4.567	1.198
4614N↔	570	N	1.377	2.162	2.167	0.744	5751S	340	S	3.125	4.562	4.567	1.198
4615V→	830	V	1.654	2.638	2.643	0.282	5756	290	F	2.062	3.151	3.156	0.240
4624V	860	V	2.503	3.629	3.633	0.900	5778	720	N	1.552	3.160	3.167	0.608
4674N↔	#	N	1.605	2.795	2.804	0.364	5778V	720	V	1.552	3.160	3.167	0.608
4701	490	N	0.408	1.004	1.008	0.208	5796	2010	S	1.562	2.686	2.690	0.375
4701N	490	N	0.408	1.004	1.008	0.208	5797	#	S	2.031	-	4.156	0.781
4739	2820	S	2.000	2.562	2.568	0.224	5857	290	F	1.000	1.499	1.503	0.312
4740	2820	S	2.180	2.999	3.003	0.250	5865	40S	S	2.000	2.750	2.754	0.187
4741←	#	N	2.200	3.022	3.028	0.422	5872S	450	S	1.375	2.000	2.006	0.311
4762N↔	740	N	1.618	2.841	2.847	0.500	5877	50S	S	2.062	2.842	2.846	0.450
4763S	#	S	1.625	2.562	2.566	0.437	5924	40S	S	2.312	3.313	3.318	0.375
4764←	860	N	1.598	2.476	2.483	0.420	5965	80S	S	3.500	4.437	4.437	0.437
4795V↔	740	V	1.391	2.482	2.488	0.344	5976S	340	S	0.875	1.245	1.256	0.187
4810V→	#	V	3.003	3.751	3.761	0.570	6064	290	F	1.875	2.965	2.971	0.234
4813V→	860	V	1.178	2.447	2.452	0.500	6074	290	F	1.937	3.622	3.627	0.375
4857↔	860	V	1.400	2.282	2.293	0.394	6077	#	S	2.062	-	4.735	0.468
4874N	#	N	2.748	3.543	3.555	0.591	6090S	2730	S	2.000	2.630	2.750	0.562
4875N→	#	N	3.250	4.249	4.282	0.650	6101	290	F	1.718	2.996	3.000	0.375
4876N→	#	N	2.748	5.500	5.512	0.850	6127	310	S	1.875	4.010	4.014	1.000
◆4898	660	S	2.047	2.598	2.603	0.295	6163S	210	S	2.000	2.875	2.879	0.703
			52	66	66.12	7.50	6186	10S	S	2.187	3.189	3.194	0.718
◆4899	660	S	2.205	2.953	2.958	0.260	6200	90S	S	1.375	2.250	2.252	1.062
			56	75	75.13	6.60	6270	210	S	3.937	5.371	5.377	0.906
◆4901	400	N	1.378	2.441	2.452	0.354	6283S	260	S	1.610	2.500	2.531	0.300
			35	62	62.28	9							
◆4904	660	S	1.929	2.441	2.447	0.335							
			49	62	62.15	8.50							
4934	790	N	1.503	2.374	2.379	0.374	6312	80S	S	1.500	2.187	2.187	0.500
4941V	#	V	1.552	3.160	3.165	0.608	6329S	70S	S	4.687	5.751	5.756	0.750
4950	880	N	1.748	2.619	2.627	0.330	6336S	260	S	1.562	2.684	2.701	0.250
◆4989	#	S	1.437	2.441	2.451	0.374	6357S	920	S	0.796	1.499	1.503	0.625
			37	62	62.26	9.50	6358	470	S	3.187	4.650	4.625	0.442
◆4990	2810	S	2.047	2.677	2.688	0.299	6370N	330	N	1.299	1.828	1.832	0.375
			52	68	68.28	7.60	6380	290	F	2.125	3.436	3.440	0.625
5070	290	F	1.813	2.965	2.969	0.250	6380S	290	F	2.125	3.436	3.440	0.625
							6389	290	F	2.125	3.126	3.131	0.484
							6426	40S	S	1.500	2.502	2.506	0.375
5109	#	S	2.497	3.245	3.248	0.485	6460S	410	S	1.875	2.758	2.762	0.500
5113	2030	S	2.000	2.745	2.751	0.230	6481S	510	S	3.125	7.000	8.250	1.003
5115	470	S	1.500	2.250	2.256	0.311	6522S	340	S	0.984	1.500	1.508	0.410
5119	490	S	2.375	3.265	3.270	0.495	6545	210	F	1.500	2.062	2.066	0.250

Part Number	Style	Matl	Shaft	Bore	O.D.	Width	Part Number	Style	Matl	Shaft	Bore	O.D.	Width
6547	2010	S	1.875	2.996	3.001	0.375	7105S	#	S	1.875	3.375	4.812	0.312
6565N	410	N	4.125	4.999	5.004	0.468	7131	#	S	8.000	11.624	11.632	0.750
6575S	2000	S	2.474	3.543	3.548	0.285	7154S	#	S	2.531	4.540	6.125	0.500
6584S	740	S	3.250	4.500	4.507	0.718	7186S	2000	S	1.812	2.718	2.722	0.270
6590S	2040	S	2.093	2.716	2.721	0.406	7188S	330	S	0.625	0.999	1.005	0.252
6597S	340	S	1.375	1.829	1.837	0.187	7208S	2000E	S	3.250	4.500	4.600	0.315
6612S	#	S	3.500	5.250	5.258	0.562	7214	490	S	0.750	1.031	1.035	0.313
6626	440	S	2.125	2.875	2.881	0.252	7235S	320	S	1.473	1.971	1.979	0.562
6626S	40S	S	2.125	2.875	2.881	0.252	7245	40S	S	1.375	2.502	2.506	0.250
6635S	450	S	4.375	6.064	6.071	0.625	7300S	790	N	1.685	2.500	2.506	1.535
6636S	350	S	2.187	3.187	3.194	0.687	7338N	560	N	3.000	3.686	3.702	0.523
6643S	520	S	2.750	-	6.200	0.700	7354N	80S	N	4.375	5.373	5.500	0.570
6644	50S	S	3.125	4.562	4.567	0.760	7378	50S	S	5.062	6.994	7.004	1.312
6649	520	S	3.125	-	8.250	0.571	7381S	240	S	1.687	2.684	2.706	0.250
6663S	890	S	4.750	6.618	6.625	1.141	7399S	240	S	0.625	0.937	0.945	0.187
6668S	330	S	1.375	1.875	1.878	0.187	7412S	480	S	1.250	1.752	1.758	0.252
6703S	350	S	1.750	2.250	2.258	0.187	7457N→	10S	N	1.656	2.623	2.627	0.455
6704	10S	S	1.125	1.874	1.878	0.625	7486S	350	S	1.750	2.374	2.380	0.311
6712NA	740	N	1.875	2.760	2.766	0.402	7512SSO	510	S	2.500	4.500	6.125	0.400
6759S	10S	S	1.500	1.997	2.001	0.531	7537S	240	S	1.500	2.062	2.068	0.219
6760S	350	S	1.375	2.062	2.073	0.375	7568	#	H	2.222	3.543	3.548	0.760
6780S	210	S	2.875	4.125	4.130	0.812	7581H	480	H	2.500	3.499	3.506	0.500
6781	2010	S	1.796	2.725	2.730	0.500	7600S	470	S	1.825	2.750	2.754	0.468
6785	350	F	2.480	3.310	3.316	0.500	7607	2810	F	1.730	2.336	2.342	0.250
6808	45	N	1.875	3.160	3.165	0.562	7686S	250	S	1.250	2.250	2.254	0.435
6815	2860	S	1.940	2.500	2.502	0.250	7687S	470	S	1.375	2.500	2.506	0.313
6818	710	S	1.740	3.000	3.008	0.500	7692S←	790	S	1.500	2.372	2.378	0.813
6832S	2040	S	1.125	1.935	1.942	0.625	7700S	210	S	4.625	6.622	6.629	1.093
6835S	330	S	0.750	1.250	1.256	0.250	7715S	#	S	1.372	2.250	2.515	1.197
6840S	40S	S	1.730	2.336	2.342	0.250	7750	480	S	0.750	1.125	1.131	0.189
6847S	#	S	1.000	1.250	1.254	0.536	7751H	330	H	1.968	2.686	2.690	0.370
6863S	350	S	0.437	1.000	1.009	0.250	7780	40S	S	2.667	3.751	3.756	0.500
6864S	450	S	4.050	5.501	5.506	0.671	7780N	40S	S	2.667	3.751	3.756	0.500
6872S	470	S	5.500	6.312	6.316	1.250	7781S	2030	S	1.250	1.983	1.989	0.251
6873S	430	S	5.500	6.500	6.505	1.125	7790H	#	H	2.125	3.193	3.198	0.812
6906S	2040	S	1.250	1.968	1.972	0.468	7834	#	S	1.750	2.502	2.506	0.680
6930	210	S	1.812	4.123	4.128	0.531	7840S	310	S	0.875	1.250	1.256	0.181
6936S	450	S	1.766	2.412	2.423	0.374	7866S	750	S	4.875	6.375	6.625	0.500
6949S	2740	S	1.750	2.875	2.880	0.500	7886S	480	S	1.500	2.437	2.441	0.250
6954S	440	S	2.062	3.000	3.006	0.313	7896S	510	S	3.110	-	5.750	0.375
6960	40S	S	1.830	2.570	2.574	0.250	7929S	330	S	0.750	1.063	1.067	0.187
6985	290	F	1.875	2.628	2.633	0.347	7934S	2040	S	1.875	2.397	2.408	0.250
6988H	330	H	1.937	2.686	2.690	0.500	7937N	410	N	2.250	3.061	3.066	0.500
7006S	430	S	5.500	6.997	7.004	1.250	7941	440	S	1.125	1.561	1.567	0.250
7013S	250	S	0.750	1.311	1.317	0.311	7994S	440	S	1.563	2.062	2.068	0.203
7014S	40S	S	0.875	1.255	1.261	0.181	8059S	250	S	0.968	1.686	1.690	0.312
7022S	2760	S	1.688	2.328	2.334	0.281	8121S	250	N	1.730	2.336	2.342	0.470
7028	250	S	0.750	1.375	1.381	0.252	8126S	890	S	5.000	6.622	6.629	0.906
7038SA←	410	S	1.687	2.502	2.508	0.582	8133S	480	S	1.362	2.191	2.197	0.252
7044NA	860	S	1.812	3.000	3.006	0.374	8139	#	F	2.000	2.961	2.971	0.250

Part Number	Style	Matl	Shaft	Bore	O.D.	Width	Part Number	Style	Matl	Shaft	Bore	O.D.	Width
8160S	320	S	1.562	2.441	2.445	0.500	9049	250	S	1.880	2.562	2.566	0.250
8165	#	H	1.875	3.000	3.005	0.625	9049N	250	S	1.880	2.562	2.566	0.250
8181NA↔	740	S	1.813	2.623	2.629	0.433	9113N	470	V	3.000	3.751	-	0.375
8243	#	F	2.125	3.146	3.153	0.500	9128S	450	S	4.166	5.501	5.509	0.610
8293S	480	S	1.238	2.250	2.254	0.500	9150S	250	S	1.938	2.578	2.583	0.294
8312	2720	S	2.136	2.902	2.909	0.310	9178S	40S	S	1.687	2.605	2.609	0.235
8312S	2720	S	2.136	2.902	2.909	0.310	9316	720	N	1.875	3.160	3.165	0.672
8314	#	S	1.796	2.524	2.800	0.599	9339S	2780	S	3.500	4.450	4.455	0.525
8314S	#	S	1.796	2.524	2.800	0.599	9342S	480	S	1.417	2.614	2.629	0.500
8316→	320	N	2.008	2.756	2.767	0.433	9344S	540	S	1.375	-	4.582	0.259
8316N	320	N	2.008	2.756	2.767	0.433	9363S	410	S	1.500	2.260	2.264	0.405
8362	330	S	1.875	2.315	2.316	0.203	9406S	2790	S	2.000	2.625	2.631	0.219
8370S	40S	S	3.797	4.501	4.506	0.250	9449	740	S	1.885	2.700	2.706	0.551
8421S	330	S	1.563	2.063	2.069	0.250	9487	680	S	1.187	1.716	1.720	0.248
8429S	#	S	1.247	-	2.633	0.480	9555S	410	S	9.500	12.499	12.509	0.687
8430S	490	S	2.125	3.000	3.006	0.313	9568	480	S	1.365	2.374	2.380	0.435
8460N	740	N	1.739	2.812	2.818	0.594	9569S	990	S	1.365	2.260	2.266	0.313
8516N	470	N	1.687	2.623	2.629	0.437	9584	740	S	3.562	4.755	4.761	0.550
8521S	2000E	S	1.873	2.684	2.684	0.544	9599S→	470	S	2.125	2.879	2.885	0.500
8549S	#	S	1.372	4.560	4.567	0.480	9600S	#	S	3.125	5.985	6.000	0.955
8594S	620	S	1.350	2.571	2.577	0.539	9613S←	710	S	1.502	2.378	2.384	0.469
8597S	480	S	1.491	2.191	2.197	0.250	9773	740	N	2.625	4.564	4.568	0.718
8609	470	S	0.812	1.250	1.254	0.254	9773R	740	N	2.625	4.564	4.568	0.718
8610→	740	S	1.524	2.656	2.662	0.391	9845→	470	V	1.766	2.412	2.418	0.375
8611N	740	S	1.521	2.656	2.662	0.424	9864S↔	570	S	2.875	3.875	3.882	0.413
8620N	470	N	1.645	2.656	2.660	0.406	9912	250	S	1.875	2.877	2.864	0.470
8622	#	S	1.940	2.813	2.817	0.428	9912S	250	S	1.875	2.877	2.864	0.470
8635S	210	S	5.500	7.624	7.631	1.250	9943	#	S	2.562	3.727	3.777	0.490
8650S	10S	S	2.125	2.996	3.001	0.687	9946N	#	N	2.500	3.125	3.130	0.547
8660S↔	480	S	1.399	2.292	2.298	0.500	10059S	470	S	1.500	2.374	-	0.313
8676S	540	S	1.375	-	4.582	0.259	10543S	10S	S	2.000	2.716	2.720	0.593
8695L	50S	S	1.550	2.669	2.675	0.500	10684S	10S	S	1.562	2.441	2.445	0.781
8695S	470	S	1.550	2.669	2.675	0.500	15003S	410	S	2.625	3.623	3.628	0.438
8704S↔	330	S	1.893	2.434	2.440	0.250	15305S	10S	S	3.500	4.501	4.506	0.875
8705S	2770	S	1.730	2.401	2.407	0.236	15379S	10S	S	3.750	4.751	4.756	0.875
8724S	410	S	7.995	11.625	11.633	1.078	30308	30S	S	2.125	3.061	3.066	0.687
8750	330	S	0.762	1.160	1.164	0.250	30365	30S	S	2.125	2.875	2.879	0.625
8750S	330	S	0.762	1.160	1.164	0.250	30737	410	S	2.250	3.189	3.149	0.437
8773S→	250	S	0.687	1.250	1.254	0.250	35012N	430	N	2.937	4.003	4.008	0.625
8792S	310	S	0.500	0.750	0.756	0.126	35949N	410	N	2.938	3.938	3.945	0.500
8835S↔	330	S	1.618	2.575	2.581	0.489	37586	#	T	6.496	7.632	7.638	0.497
8871	2860	S	2.000	2.562	2.568	0.224	37921	TPDW	T	4.125	4.999	5.005	1.037
8907	#	S	5.937	6.801	0.000	1.125	37939	TPDW	T	4.000	4.999	5.005	0.500
8935S	790	S	1.558	2.250	2.254	1.520	38832	940	T	0.875	1.375	1.379	0.312
8940S	480	S	1.523	2.714	2.720	0.500	39044←	900	T	6.238	8.654	8.661	0.560
8974S	490	S	2.180	3.000	3.006	0.500	39140	940	T	1.375	2.125	2.129	0.375
8975S	490	S	2.512	3.506	3.519	0.290	39302	TW-H	T	2.125	3.189	3.194	0.437
8976S	490	S	3.125	4.175	4.186	0.295	39608	TDW-H	T	3.750	4.750	4.756	0.500
8998	440	S	1.996	2.000	2.878	0.250	39701	TFW-H	T	7.250	8.125	8.133	0.500
9015S	440	S	2.000	2.565	2.571	0.500	39703	TFW-H	T	3.625	4.751	4.756	0.500

Part Number	Style	Matl	Shaft	Bore	O.D.	Width	Part Number	Style	Matl	Shaft	Bore	O.D.	Width
39705	TFW-H	T	3.750	4.750	4.756	0.500	39910	TW	T	1.000	1.437	1.441	0.250
39711	TFW-H	T	1.562	2.125	2.129	0.375	39920	TFW-H	T	1.562	2.062	2.067	0.188
39713	TDW-H	T	1.250	1.812	1.817	0.235	39925	TFW-H	T	1.781	2.500	2.505	0.312
39715	#	T	6.000	7.475	7.481	0.590	39926	TW-H	T	3.740	6.772	6.775	1.102
39717	#	T	2.125	3.189	3.194	0.437	39930	TFW-H	T	1.812	2.562	2.567	0.315
39719	#	T	2.125	3.189	3.194	0.437	39952	TFW-H	T	4.646	5.751	5.756	0.500
39723	TFW-H	T	4.000	5.000	5.005	0.500	39954	TDW-H	T	4.835	5.749	5.756	0.375
39732	TW-H	T	4.750	6.000	6.006	0.562	39956	TDW-H	T	5.997	7.125	7.131	0.500
39801	TFW-H	T	5.000	6.000	6.006	0.413	39958	TFW-H	T	5.000	6.125	6.131	0.500
39802	TFW-H	T	2.875	3.623	3.628	0.500	40027S	40S	S	0.750	1.375	1.379	0.250
39803	TFW-H	T	2.500	3.130	3.135	0.315	40059S	40S	S	0.875	1.499	1.505	0.252
39804	TFW-H	T	2.953	3.661	3.666	0.315	40063S	40S	S	1.500	2.438	2.444	0.250
39805	TFW-H	T	5.118	5.906	5.923	0.583	40071S	40S	S	1.875	2.623	2.627	0.250
39806→	TFW-H	T	5.118	5.906	5.923	0.571	40085S	40S	S	2.000	2.996	3.002	0.250
39807	TW-H	T	6.000	6.750	6.756	0.437	40094S	40S	S	1.937	3.189	3.194	0.250
39809	TW-H	T	3.125	4.125	4.130	0.437	40101S	40S	S	2.375	3.350	3.355	0.250
39813	TW-H	T	3.625	4.751	4.756	0.500	40140S	40S	S	1.250	1.752	1.756	0.250
39815	TDW-H	T	7.250	8.125	8.132	0.940	40154S	40S	S	1.687	2.502	2.506	0.250
39817	TFW-H	T	3.125	4.126	4.130	0.437	40157S	40S	S	1.000	2.000	2.011	0.252
39821	TW	T	2.272	2.654	2.661	0.250	40160S	40S	S	1.125	2.000	2.004	0.250
39823	TDW-H	T	6.000	6.750	6.757	0.625	40162S	40S	S	1.187	2.000	2.004	0.250
39825	TFW-H	T	4.750	6.000	6.006	0.562	40169S	40S	S	1.375	2.250	2.254	0.250
39827	TDW-H	T	4.750	6.000	6.006	0.562	40185	40S	S	1.562	2.502	2.506	0.250
39835	TW	T	1.812	2.563	2.567	0.375	40208	40S	S	0.968	1.499	1.503	0.250
39837	TW-H	T	3.750	4.750	4.756	0.500	40230S	40S	S	1.000	1.752	1.756	0.250
39849	TFW-H	T	4.375	5.501	5.506	0.500	40286	40S	S	1.625	2.750	2.754	0.250
39851	TFW-H	T	2.125	2.875	2.879	0.437	40301S	40S	S	2.000	3.000	3.005	0.250
39853	TFW-H	T	2.125	2.875	2.879	0.437	40316S	40S	S	2.250	3.251	3.258	0.251
39861	#	T	6.496	9.600	9.606	0.540	40337S	40S	S	2.500	3.148	3.154	0.250
39865	#	T	3.543	6.215	6.220	0.562	40360S	40S	S	2.000	2.686	2.690	0.250
39867	TW-H	T	0.984	1.614	1.618	0.315	40370S	40S	S	1.968	2.960	2.964	0.250
39869	#	T	1.102	1.614	1.618	0.315	40375←	320	T	3.228	3.791	3.802	0.315
39875	#	T	1.496	2.126	2.130	0.984	40382	40S	S	1.500	1.983	1.987	0.250
39877	TW2	T	1.929	2.563	2.567	0.315	40389S	40S	S	2.000	2.750	2.756	0.252
39879	TFW-H	T	1.299	1.779	1.784	0.256	40392	TFW-H	T	2.756	4.000	4.009	0.469
39880	940	T	5.000	5.999	6.006	0.413	40395	40S	S	1.375	1.874	1.879	0.250
39881	TFW-H	T	4.993	6.000	6.006	0.413	40395S	40S	S	1.375	1.874	1.879	0.250
39882	TFW-H	T	3.620	4.625	4.630	0.400	40401	40S	S	2.000	2.501	2.506	0.250
39883	900	T	6.238	8.655	8.661	1.100	40410S	40S	S	2.000	2.624	2.630	0.250
39885	TFW-H	T	6.198	7.328	7.336	0.354	40433S	40S	S	2.250	3.125	3.130	0.250
39886	TDW-H	T	6.202	7.329	7.336	0.377	40438S	40S	S	1.562	2.374	2.378	0.250
39887	TFW-H	T	6.204	7.330	7.336	0.445	40468	40S	S	1.484	2.254	2.258	0.250
39888	TFW-H	T	6.198	7.328	7.336	0.445	40494S	40S	S	1.750	2.501	2.507	0.251
39889	TW-H	T	6.077	7.328	7.336	0.445	40520S	40S	S	2.250	3.000	3.006	0.250
39890	TW-H	T	6.077	7.328	7.336	0.445	40522S	40S	S	1.375	2.000	2.004	0.250
39893	TFW-H	T	9.052	10.709	10.720	0.625	40555	40S	S	2.500	3.000	3.005	0.250
39894	TFW-H	T	9.052	10.709	10.720	0.625	40555S	40S	S	2.500	3.000	3.005	0.250
39899	#	T	11.220	12.250	12.260	0.945	40566S	40S	S	2.125	2.875	2.881	0.252
39900	#	T	11.220	12.250	12.260	0.945	40568S	40S	S	1.625	2.625	2.629	0.250
39904	TFF	T	1.312	1.828	1.833	0.250	40576S	40S	S	1.187	1.996	2.000	0.250

Part Number	Style	Matl	Shaft	Bore	O.D.	Width	Part Number	Style	Matl	Shaft	Bore	O.D.	Width
40652S	40S	S	1.250	2.000	2.011	0.250	45637S	40S	S	4.687	6.002	6.007	0.250
40769S	40S	S	1.313	2.282	2.286	0.250	45653S	40S	S	1.937	3.500	3.505	0.250
40973S	40S	S	2.093	3.150	3.156	0.250	45825S	40S	S	3.125	3.751	3.756	0.250
41013S	40S	S	2.093	2.750	2.754	0.250	45827S	40S	S	2.750	3.501	3.505	0.250
41026S	40S	S	2.375	3.000	3.005	0.250	46997S	40S	S	2.750	3.751	3.756	0.250
41075S	40S	S	2.250	3.443	3.447	0.250	47150S	40S	S	4.250	5.251	5.259	0.251
41163T→	TFW-H	T	2.625	3.696	3.700	0.500	477055S	47	S	3.330	4.125	4.130	0.562
41224S	40S	S	1.000	1.499	1.503	0.250	50027S	450	S	0.750	1.375	1.379	0.406
41257	40S	S	1.500	1.989	1.993	0.250	50081	50S	S	1.718	2.875	2.879	0.468
41264S	40S	S	0.625	1.250	1.254	0.250	50126	50S	S	1.406	2.125	2.129	0.437
41267S	40S	S	0.875	1.375	1.381	0.250	50151S	50S	S	1.125	1.563	1.569	0.252
41389S	40S	S	0.750	1.250	1.254	0.250	50197S	50S	S	0.375	0.999	1.005	0.313
41442S	40S	S	0.498	0.998	1.007	0.251	50199S	50S	S	0.437	0.999	1.005	0.250
41466S	40S	S	0.625	1.124	1.133	0.250	50209	50S	S	1.031	1.499	1.503	0.390
41509	TPDW	T	6.500	8.000	8.007	0.625	50266	50S	S	1.781	2.623	2.627	0.500
41510	TPDW	T	6.500	8.000	8.007	0.625	50289	50S	S	1.750	2.783	2.787	0.531
41526S	40S	S	0.500	1.124	1.128	0.250	50327	50S	S	1.718	2.437	2.441	0.468
41536	TPDW	T	2.875	3.750	3.755	0.500	50385	50S	H	0.375	0.750	0.756	0.252
41537	TPDW	T	2.875	3.750	3.755	0.500	50385S	50S	S	0.375	0.750	0.756	0.252
417698S	41	S	3.625	4.376	4.381	0.375	50395S	50S	S	1.374	1.874	1.880	0.251
41787S	40S	S	1.250	2.062	2.066	0.250	50402	50S	S	1.375	2.282	2.286	0.500
42081S	40S	S	1.250	2.250	2.256	0.250	50445	50S	S	0.312	1.250	1.254	0.375
42101S	40S	S	2.129	2.891	2.895	0.250	50468	50S	S	1.484	2.254	2.258	0.312
42260S	40S	S	1.500	1.938	1.942	0.250	50470S	50S	S	0.437	0.875	0.881	0.252
42280S	40S	S	0.875	1.250	1.254	0.250	50480S	450	S	1.375	-	-	0.375
42311S	40S	S	1.000	1.438	1.444	0.250	50528	50S	S	1.968	2.996	3.001	0.500
42352S	40S	S	1.750	2.250	2.254	0.250	50560	50S	S	2.468	3.350	3.355	0.468
42421S	40S	S	1.875	2.750	2.754	0.250	50568	50S	T	1.625	2.625	2.629	0.500
42763	40S	S	1.375	2.282	2.286	0.250	50569	50S	T	1.625	2.625	2.629	0.500
43034S	40S	S	2.250	2.875	2.879	0.250	50631	50S	S	2.218	3.350	3.355	0.468
43071S	40S	S	1.750	2.438	2.444	0.251	50737	50S	S	2.250	3.189	3.194	0.437
43072S	40S	S	1.125	1.564	1.568	0.250	51032S	50S	S	1.281	1.752	1.756	0.375
43073S	40S	S	2.000	2.717	2.721	0.250	51083	50S	S	1.750	2.750	2.756	0.500
43074S	40S	S	1.578	2.000	2.004	0.250	51098	480	S	1.500	2.502	2.508	0.311
43076S	40S	S	1.187	2.047	2.051	0.250	51322	50S	S	1.365	2.081	2.087	0.435
43077S	40S	S	2.625	3.484	3.489	0.250	55010	410	S	2.812	3.876	3.881	0.437
43078S	40S	S	1.500	2.192	2.196	0.250	55028	50S	S	3.562	4.999	5.004	0.468
43080S	40S	S	0.500	0.875	0.879	0.218	55030	50S	S	3.687	4.999	5.004	0.468
43086S	40S	S	2.875	4.003	4.008	0.250	55078S	50S	S	9.750	11.250	11.260	0.750
43089S	40S	S	1.375	2.374	2.378	0.250	55103S	450	S	16.250	18.000	18.010	0.750
43095S	40S	S	0.500	0.749	0.753	0.093	55238	50S	S	2.750	4.999	5.004	0.468
43109S	40S	S	2.312	3.065	3.070	0.281	55249	450	S	3.375	4.688	4.693	0.500
43290S	40S	S	2.500	3.125	3.130	0.250	55301S	450	S	9.000	10.000	10.010	0.750
44052	40S	S	2.250	3.310	3.317	0.375	55337	50S	S	2.250	3.876	3.881	0.468
44053	40S	S	1.821	2.623	2.627	0.250	55353	50S	S	3.625	4.839	4.844	0.500
45013S	40S	S	3.000	4.003	4.008	0.250	55357	50S	S	5.437	6.749	6.757	0.625
45031S	40S	S	3.750	4.999	5.004	0.250	55419	50S	S	3.437	4.501	4.506	0.625
45187S	40S	S	4.000	4.876	4.881	0.250	55524	50S	S	2.000	4.003	4.008	0.468
45525S	40S	S	3.500	4.125	4.130	0.250	55547	450	S	3.875	5.126	5.131	0.625
455958S	450	S	3.875	5.375	5.383	0.438	55548	50S	S	3.000	4.626	4.631	0.500

Part Number	Style	Matl	Shaft	Bore	O.D.	Width	Part Number	Style	Matl	Shaft	Bore	O.D.	Width
55563	50S	T	3.250	4.003	4.008	0.468	◆112207XX	350	S	0.433 11	0.866 22	0.877 22.28	0.276 7
55581	450	S	3.880	5.690	5.695	0.500	◆112607XX	350	S	0.433 11	1.024 26	1.035 26.28	0.276 7
57831	50S	S	4.062	6.191	6.197	0.625	◆121905XX	320	S	0.472 12	0.748 19	0.756 19.20	0.197 5
◆61607XX	350	S	0.236 6	0.63 16	0.641 16.28	0.276 7	◆122005XX	320	S	0.472 12	0.787 20	0.798 20.28	0.197 5
◆62207XX	350	S	0.236 6	0.866 22	0.877 22.28	0.276 7	◆122207XX	350	S	0.472 12	0.866 22	0.876 22.25	0.276 7
◆71607XX	320	S	0.276 7	0.63 16	0.641 16.28	0.276 7	◆122407XX	320	S	0.472 12	0.945 24	0.954 24.23	0.276 7
◆72207XX	350	S	0.276 7	0.866 22	0.877 22.28	0.276 7	◆122507XX	480	S	0.472 12	0.984 25	0.994 25.25	0.276 7
75251S	70S	S	4.820	5.751	5.756	0.750	◆122607XX	320	S	0.472 12	1.024 26	1.031 26.20	0.276 7
80313	2000E	S	2.062	3.250	3.310	0.500	◆122807XX	350	S	0.472 12	1.102 28	1.11 28.20	0.276 7
80330	80S	S	2.500	3.371	3.435	0.500	◆123007XX	350	S	0.472 12	1.181 30	1.189 30.20	0.276 7
◆81404XX	350	S	0.315 8	0.551 14	0.559 14.20	0.157 4	◆123207XX	350	S	0.472 12	1.26 32	1.268 32.20	0.276 7
◆81607XX	350	S	0.315 8	0.63 16	0.639 16.23	0.276 7	◆123507XX	320	S	0.472 12	1.378 35	1.386 35.20	0.276 7
◆81805XX	350	S	0.315 8	0.709 18	0.717 18.20	0.197 5	◆132206XX	320	S	0.512 13	0.866 22	0.874 22.20	0.236 6
◆81807XX	320	S	0.315 8	0.709 18	0.717 18.20	0.276 7	◆132607XX	320	S	0.512 13	1.024 26	1.031 26.20	0.276 7
◆82207XX	320	S	0.315 8	0.866 22	0.877 22.28	0.276 7	◆132807XX	320	S	0.512 13	1.102 28	1.11 28.20	0.276 7
◆82207XX	320	S	0.315 8	0.866 22	0.874 22.20	0.276 7	◆133007XX	320	S	0.512 13	1.181 30	1.189 30.20	0.276 7
◆82407XX	350	S	0.315 8	0.945 24	0.956 24.28	0.276 7	◆142407XX	350	S	0.551 14	0.945 24	0.954 24.23	0.276 7
◆91807XX	350	S	0.354 9	0.709 18	0.717 18.20	0.276 7	◆142505XX	320	S	0.551 14	0.984 25	0.993 25.23	0.197 5
◆92207XX	350	S	0.354 9	0.866 22	0.874 22.20	0.276 7	◆142607XX	320	S	0.551 14	1.024 26	1.033 26.23	0.276 7
◆92407XX	350	S	0.354 9	0.945 24	0.956 24.28	0.276 7	◆142707XX	320	S	0.551 14	1.063 27	1.071 27.20	0.276 7
◆92607XX	350	S	0.354 9	1.024 26	1.035 26.28	0.276 7	◆142806XX	350	S	0.551 14	1.102 28	1.111 28.23	0.236 6
100058	TW	T	2.156	2.880	2.885	0.375	◆143007XX	320	S	0.551 14	1.181 30	1.189 30.20	0.276 7
100085←	#	T	3.858	4.525	4.540	0.620	◆143207XX	320	S	0.551 14	1.26 32	1.268 32.20	0.276 7
100165	#	S	1.378	2.244	2.246	0.601	◆143507XX	350	S	0.551 14	1.378 35	1.387 35.22	0.276 7
100357	860	V	1.705	3.034	3.039	0.562	◆152407XX	350	S	0.591 15	0.945 24	0.954 24.23	0.276 7
100494	Unitized	V	3.253	4.249	4.260	0.635	◆152505XX	320	S	0.591 15	0.984 25	0.992 25.20	0.197 5
100495	Unitized	V	3.003	3.751	3.761	0.420	◆152507XX	350	S	0.591 15	0.984 25	0.992 25.20	0.276 7
100557	Unitized	V	3.253	5.500	5.511	0.635	◆152607XX	350	S	0.591 15	1.024 26	1.033 26.23	0.276 7
100675	720	V	1.875	3.161	3.165	0.695	◆152807XX	320	S	0.591 15	1.102 28	1.11 28.20	0.276 7
◆101907XX	350	S	0.394 10	0.748 19	0.756 19.20	0.276 7	◆153007XX	350	S	0.591 15	1.181 30	1.19 30.23	0.276 7
◆102207XX	320	S	0.394 10	0.866 22	0.877 22.28	0.276 7							
◆102407XX	350	S	0.394 10	0.945 24	0.954 24.23	0.276 7							
◆102507XX	320	S	0.394 10	0.984 25	0.995 25.28	0.276 7							
◆102607XX	320	S	0.394 10	1.024 26	1.033 26.23	0.276 7							
◆111704XX	320	S	0.433 11	0.669 17	0.679 17.25	0.157 4							

Part Number	Style	Matl	Shaft	Bore	O.D.	Width	Part Number	Style	Matl	Shaft	Bore	O.D.	Width
◆153207XX	350	S	0.591 15	1.26 32	1.268 32.20	0.276 7	◆183007XX	350	S	0.709 18	1.181 30	1.19 30.23	0.276 7
◆153207XX	350	S	0.591 15	1.26 32	1.268 32.20	0.276 7	◆183207XX	350	S	0.709 18	1.26 32	1.268 32.20	0.276 7
◆153208XX	350	S	0.591 15	1.26 32	1.269 32.22	0.315 8	◆183208XX	350	S	0.709 18	1.26 32	1.269 32.22	0.315 8
◆153507XX	350	S	0.591 15	1.378 35	1.387 35.23	0.276 7	◆183507XX	320	S	0.709 18	1.378 35	1.385 35.18	0.276 7
◆153706XX	320	S	0.591 15	1.457 37	1.465 37.20	0.236 6	◆183708XX	320	S	0.709 18	1.457 37	1.465 37.20	0.315 8
◆154007XX	320	S	0.591 15	1.575 40	1.583 40.20	0.276 7	◆183807XX	320	S	0.709 18	1.496 38	1.504 38.20	0.276 7
◆162204XX	320	S	0.63 16	0.866 22	0.874 22.20	0.157 4	◆184007XX	350	S	0.709 18	1.575 40	1.583 40.22	0.276 7
◆162405XX	350	S	0.63 16	0.984 25	0.992 25.20	0.197 5	◆192706XX	350	S	0.748 19	1.063 27	1.071 27.20	0.236 6
◆162406XX	320	S	0.63 16	0.945 24	0.953 24.20	0.236 6	◆193007XX	320	S	0.748 19	1.181 30	1.189 30.20	0.276 7
◆162407XX	320	S	0.63 16	0.945 24	0.953 24.20	0.276 7	◆193207XX	350	S	0.748 19	1.26 32	1.268 32.20	0.276 7
◆162607XX	320	S	0.63 16	1.024 26	1.031 26.20	0.276 7	◆193208XX	320	S	0.748 19	1.26 32	1.268 32.20	0.315 8
◆162807XX	350	S	0.63 16	1.102 28	1.111 28.23	0.276 7	◆193510XX	350	S	0.748 19	1.378 35	1.387 35.23	0.394 10
◆162807XX	350	S	0.63 16	1.102 28	1.11 28.20	0.276 7	◆194010XX	350	S	0.748 19	1.575 40	1.584 40.23	0.394 10
◆163007XX	350	S	0.63 16	1.181 30	1.19 30.23	0.276 7	◆194707XX	320	S	0.748 19	1.85 47	1.858 47.20	0.276 7
◆163207XX	320	S	0.63 16	1.26 32	1.271 32.28	0.276 7	200110	2000	S	2.058	3.149	3.154	0.270
◆163507XX	350	S	0.63 16	1.378 35	1.387 35.23	0.276 7	200133	2000E	S	3.000	4.524	4.600	0.433
◆163807XX	320	S	0.63 16	1.496 38	1.504 38.20	0.276 7	200322	2000	S	2.953	4.724	4.729	0.320
◆164007XX	320	S	0.63 16	1.575 40	1.583 40.20	0.276 7	200338	2000	S	1.250	2.000	2.004	0.290
◆172707XX	320	S	0.669 17	1.063 27	1.071 27.20	0.276 7	200339	2000	S	2.000	2.875	2.879	0.290
◆172807XX	350	S	0.669 17	1.102 28	1.111 28.23	0.276 7	200354	2000	S	1.750	2.718	2.722	0.359
◆173007XX	350	S	0.669 17	1.181 30	1.19 30.23	0.276 7	200371	2000	S	1.945	2.891	2.895	0.290
◆173207XX	350	S	0.669 17	1.26 32	1.269 32.22	0.276 7	200392	2000	S	2.625	3.813	3.818	0.415
◆173507XX	350	S	0.669 17	1.378 35	1.385 35.18	0.276 7	200600	2000E	S	1.750	2.786	2.876	0.285
◆173508XX	350	S	0.669 17	1.378 35	1.386 35.20	0.315 8	200603	2000E	S	3.625	4.695	4.810	0.395
◆173707XX	320	S	0.669 17	1.457 37	1.465 37.20	0.276 7	200640	2000E	S	1.562	2.531	2.621	0.285
◆173807XX	320	S	0.669 17	1.496 38	1.504 38.20	0.276 7	200640S	200E	S	1.562	2.531	2.621	0.285
◆174007XX	350	S	0.669 17	1.575 40	1.584 40.23	0.276 7	200641	2000E	S	1.625	2.462	-	.250
◆174707XX	350	S	0.669 17	1.85 47	1.858 47.20	0.276 7	200642	2000	S	4.750	6.002	6.092	0.285
◆174708XX	320	S	0.669 17	1.85 47	1.858 47.20	0.315 8	200752	2000E	S	1.873	2.716	2.806	0.281
◆182806XX	350	S	0.709 18	1.102 28	1.113 28.28	0.236 6	200763	2000E	S	2.250	3.249	3.250	0.285
							200766	2000E	S	3.062	4.230	4.350	0.390
							200851	2000E	S	2.496	3.672	3.772	0.315
							200854	2000E	S	1.750	2.718	2.728	0.294
							200855	2000E	S	2.375	3.471	3.616	0.290
							200855S	200E	S	2.375	3.471	3.616	0.290
							200859	2000	S	1.500	2.256	-	.270
							200861	2000E	S	1.500	2.462	2.482	0.290
							200865	2000E	S	2.065	3.130	3.130	0.294
							200870	2000E	S	3.249	4.468	4.488	0.318
							200881	2000E	S	2.000	2.804	2.824	0.294

Part Number	Style	Matl	Shaft	Bore	O.D.	Width	Part Number	Style	Matl	Shaft	Bore	O.D.	Width
200885	2000E	S	1.991	2.900	2.975	0.290	204501	2040	S	1.750	3.000	3.005	0.250
200886	2000E	S	1.687	2.650	2.725	0.290	204502	2040	S	1.750	2.561	2.567	0.252
200886S	200E	S	1.687	2.650	2.725	0.290	204503	2040	S	1.750	2.374	2.379	0.250
200887	2000E	S	1.562	2.237	2.257	0.290	204505	2040	S	1.125	1.780	1.785	0.250
200929	2000E	S	2.250	3.400	3.700	0.280	204506	2040	S	2.000	3.623	3.628	0.250
200942	2000E	S	2.750	3.846	3.928	0.290	204507	2040	S	1.250	1.979	1.985	0.252
◆202806XX	320	S	0.787 20	1.102 28	1.11 28.20	0.236 6	204508	2040	S	2.000	3.062	3.066	0.250
203002	2030	S	1.750	2.717	2.721	0.406	204509	2040	S	5.000	6.250	6.256	0.250
203003	2030	S	1.125	1.937	1.942	0.562	◆204707XX	350	S	0.787 20	1.85 47	1.859 47.22	0.276 7
203005	2030	S	1.000	1.780	1.785	0.468	205004	2050	F	1.125	1.937	1.942	0.625
203005S	203	S	1.000	1.780	1.785	0.468	205005	2050	F	1.000	1.780	1.785	0.468
203006	2030	S	1.812	2.561	2.566	0.500	205015	2050	F	1.750	2.563	2.569	0.500
203006S	2030	S	1.812	2.561	2.566	0.500	205017	2050	F	1.625	2.328	2.327	0.406
◆203007XX	350	S	0.787 20	1.181 30	1.192 30.28	0.276 7	205035	2050	F	2.296	3.148	3.153	0.359
203008	2030	S	1.687	2.327	2.332	0.500	205044	2050	F	2.000	2.964	2.965	0.500
203012	2030	S	1.250	1.969	1.975	0.469	205058	2050	S	2.000	2.562	2.566	0.500
203013	2030	S	1.500	2.327	2.333	0.406	◆205207XX	350	S	0.787 20	2.047 52	2.055 52.20	0.276 7
203016	2030	S	1.218	1.968	1.972	0.468	210295	210	S	1.937	2.875	2.879	0.687
203025	2030	S	1.219	1.979	1.985	0.406	210945	210	S	1.750	3.371	3.376	0.625
203029	2030	S	1.250	1.979	1.985	0.406	◆213507XX	320	S	0.827 21	1.378 35	1.386 35.20	0.276 7
◆203207XX	350	S	0.787 20	1.26 32	1.269 32.23	0.276 7	◆213508XX	320	S	0.827 21	1.378 35	1.386 35.20	0.315 8
◆203507XX	350	S	0.787 20	1.378 35	1.387 35.23	0.276 7	◆220818	320	S	0.315 8	0.709 18	0.717 18.20	0.276 7
◆203607XX	320	S	0.787 20	1.417 36	1.425 36.20	0.276 7	◆220860	350	S	0.315 8	0.630 16	0.638 16.20	0.236 6
◆203707XX	320	S	0.787 20	1.457 37	1.465 37.20	0.276 7	◆220918	350	S	9.000 9	0.709 18	0.717 18.20	0.276 7
◆203708XX	320	S	0.787 20	1.457 37	1.465 37.20	0.315 8	◆221040	350	S	0.394 10	0.748 19	0.757 19.23	0.276 7
◆203807XX	320	S	0.787 20	1.496 38	1.504 38.20	0.276 7	◆221122	350	S	0.433 11	0.866 22	0.875 22.23	0.276 7
204002	2040	S	1.750	2.716	2.721	0.406	◆221207	350	S	0.472 12	0.866 22	0.876 22.25	0.276 7
204005	2040	S	1.000	1.781	1.787	0.469	◆221208	350	V	0.472 12	0.866 22	0.875 22.23	0.276 7
204005S	2040	S	1.000	1.781	1.787	0.469	◆221410	350	S	0.551 14	0.945 24	0.954 24.23	0.236 6
◆204007XX	350	S	0.787 20	1.575 40	1.584 40.23	0.276 7	◆221510	320	N	0.591 15	0.984 25	0.994 25.25	0.236 6
◆204010XX	350	S	0.787 20	1.575 40	1.584 40.23	0.394 10	◆221540	350	S	0.591 15	1.181 30	1.190 30.23	0.276 7
204013	2040	S	1.500	2.327	2.333	0.406	◆221607	#	N	0.630 16	1.063 27	1.071 27.20	0.551 14
204017	2040	S	1.625	2.328	2.334	0.437	◆221610	320	N	0.630 16	1.102 28	1.111 28.22	0.276 7
204020	2040	S	1.125	1.781	1.787	0.469	◆221620	350	S	0.630 16	1.181 30	1.190 30.23	0.276 7
204027	2040	S	1.375	2.327	2.332	0.406	◆221710	350	S	0.669 17	1.102 28	1.111 28.22	0.276 7
204029	2040	S	1.250	1.979	1.983	0.406	◆221720	470	S	0.669 17	1.181 30	1.190 30.23	0.276 7
204035	2040	S	2.293	3.148	3.154	0.358	◆221730	350	S	0.669 17	1.260 32	1.269 32.23	0.276 7
204038	2040	S	1.750	2.718	2.724	0.359							
◆204207XX	350	S	0.787 20	1.654 42	1.663 42.25	0.276 7							
◆204210XX	320	S	0.787 20	1.654 42	1.659 42.15	0.394 10							
204500	40S	S	1.625	2.562	2.568	0.252							

Part Number	Style	Matl	Shaft	Bore	O.D.	Width	Part Number	Style	Matl	Shaft	Bore	O.D.	Width
◆221735	350	S	0.669 17	1.378 35	1.387 35.23	0.276 7	222742	480	V	1.063	1.654	1.657	0.276
◆221820	320	S	0.709 18	1.181 30	1.190 30.23	0.315 8	◆222743←	320	H	1.063 27	1.693 43	1.701 43.20	0.354 9
◆221830	350	S	0.709 18	1.260 32	1.269 32.23	0.276 7	◆222745←	320	N	1.063 27	1.772 45	1.781 45.24	0.354 9
◆221920	320	S	0.748 19	1.181 30	1.190 30.23	0.197 5	◆222820	330	S	1.102 28	1.575 40	1.584 40.23	0.276 7
◆221922	320	S	0.748 19	1.260 32	1.269 32.23	0.315 8	◆222830	320	N	1.102 28	1.614 41	1.625 41.27	0.276 7
◆221925	350	S	0.748 19	1.417 36	1.426 36.23	0.256 6.50	◆222835	320	N	1.102 28	1.732 44	1.741 44.22	0.236 6
◆222020	350	S	0.787 20	1.260 32	1.269 32.23	0.276 7	◆222860→	320	N	1.102 28	1.850 47	1.859 47.22	0.315 8
◆222025	350	S	0.787 20	1.181 30	1.190 30.23	0.276 7	◆223005	480	S	1.181 30	1.575 40	1.584 40.23	0.276 7
222028	320	S	0.787	1.339	1.348	0.276	◆223010→	320	S	1.181 30	1.654 42	1.663 42.24	0.276 7
◆222030→	320	S	0.787 20	1.378 35	1.387 35.23	0.217 5.50	◆223012→	320	N	1.181 30	1.732 44	1.741 44.22	0.354 9
◆222036	320	V	0.787 20	1.417 36	1.426 36.22	0.276 7	◆223014	320	S	1.181 30	1.772 45	1.781 45.24	0.236 6
◆222050	350	S	0.787 20	1.575 40	1.584 40.23	0.276 7	◆223018→	320	S	1.181 30	1.811 46	1.820 46.23	0.276 7
◆222060	350	S	0.787 20	1.850 47	1.859 47.22	0.276 7	◆223020	350	S	1.181 30	1.850 47	1.859 47.22	0.276 7
◆222210	350	S	0.866 22	1.260 32	1.269 32.23	0.276 7	◆223035	350	S	1.181 30	2.047 52	2.058 52.27	0.276 7
◆222220	320	S	0.866 22	1.378 35	1.387 35.23	0.276 7	◆223050←	320	S	1.181 30	1.969 50	1.978 50.24	0.354 9
◆222238	320	S	0.866 22	1.496 38	1.504 38.20	0.315 8	◆223207XX	350	S	0.866 22	1.26 32	1.269 32.23	0.276 7
◆222240	350	S	0.866 22	1.575 40	1.584 40.23	0.276 7	◆223210	340	S	1.260 32	1.575 40	1.581 40.15	0.197 5
◆222242	320	N	0.866 22	1.575 40	1.584 40.23	0.354 9	◆223215←	320	S	1.260 32	1.654 42	1.661 42.20	0.394 10
◆222267←	320	H	0.866 22	1.772 45	1.781 45.24	0.315 8	◆223220→	320	N	1.260 32	1.732 44	1.741 44.22	0.236 6
222310	340	S	0.905	1.260	1.268	0.197	◆223230	320	S	1.260 32	1.772 45	1.781 45.24	0.276 7
◆222330←	320	N	0.906 23	1.339 34	1.348 34.24	0.315 8	◆223235→	320	N	1.260 32	1.811 46	1.820 46.23	0.236 6
◆222410	350	S	0.945 24	1.378 35	1.387 35.23	0.276 7	◆223240→	400	N	1.260 32	1.890 48	1.899 48.24	0.276 7
◆222430	350	S	0.945 24	1.575 40	1.584 40.23	0.276 7	◆223250→	320	S	1.260 32	1.969 50	1.978 50.24	0.315 8
222450	250	S	0.945	1.693	1.702	0.315	◆223252←	320	N	1.260 32	2.047 52	2.058 52.28	0.433 11
◆222510	350	S	0.984 25	1.378 35	1.383 35.13	0.276 7	◆223253→	320	N	1.260 32	2.087 53	2.098 53.29	0.276 7
◆222535→	320	S	0.984 25	1.496 38	1.505 38.23	0.276 7	◆223255	350	S	1.260 32	2.047 52	2.058 52.27	0.276 7
◆222540	470	S	0.984 25	1.575 40	1.584 40.23	0.276 7	◆223340→	320	S	1.299 33	1.850 47	1.859 47.22	0.276 7
222556→	320	H	0.984	1.654	1.665	0.315	◆223400	320	N	1.339 34	1.732 44	1.741 44.23	0.315 8
◆222560	350	S	0.984 25	1.850 47	1.859 47.22	0.276 7	◆223420→	320	N	1.339 34	1.890 48	1.899 48.24	0.315 8
◆222580	320	S	0.984 25	2.441 62	2.452 62.28	0.394 10	◆223440	320	N	1.339 34	2.087 53	2.098 53.28	0.315 8
222630	320	N	1.024	1.496	1.504	0.315							
◆222655→	320	S	1.024 26	1.890 48	1.899 48.24	0.276 7							

Part Number	Style	Matl	Shaft	Bore	O.D.	Width	Part Number	Style	Matl	Shaft	Bore	O.D.	Width
◆223507XX	350	S	0.866 22	1.378 35	1.387 35.23	0.276 7	◆223840	470	S	1.496 38	2.283 58	2.290 58.17	0.315 8
◆223510	350	S	1.378 35	1.850 47	1.859 47.22	0.276 7	223842	480	V	1.496	2.283	2.288	0.315
◆223520	350	S	1.378 35	1.969 50	1.980 50.29	0.315 8	◆223843	350	S	1.496 38	2.362 60	2.373 60.27	0.394 10
◆223535	330	S	1.378 35	2.047 52	2.053 52.15	0.276 7	◆224007XX	350	S	0.866 22	1.575 40	1.584 40.23	0.276 7
◆223540	320	N	1.378 35	2.165 55	2.176 55.27	0.315 8	◆224008XX	350	S	0.866 22	1.575 40	1.583 40.20	0.315 8
◆223542	320	N	1.378 35	2.165 55	2.176 55.27	0.315 8	◆224010	350	S	1.575 40	2.047 52	2.053 52.15	0.276 7
◆223543	320	S	1.378 35	2.205 56	2.216 56.29	0.394 10	◆224015→	320	S	1.575 40	2.047 52	2.058 52.27	0.236 6
◆223550	450	S	1.378 35	2.283 58	2.294 58.27	0.394 10	◆224020→	320	S	1.575 40	2.165 55	2.176 55.27	0.315 8
◆223552	320	S	1.378 35	2.441 62	2.452 62.28	0.276 7	◆224025→	320	N	1.567 40	2.205 56	2.216 56.29	0.315 8
◆223553→	400	N	1.378 35	2.441 62	2.452 62.28	0.354 9	◆224026↔	350	V	1.575 40	2.205 56	2.216 56.29	0.354 9
◆223554	#	S	1.378 35	2.480 63	2.487 63.17	0.394 10	◆224040	350	S	1.575 40	2.362 60	2.373 60.27	0.394 10
◆223555	470	N	1.378 35	2.520 64	2.525 64.13	0.315 8	◆224045	320	S	1.575 40	2.441 62	2.452 62.28	0.433 11
◆223580→	400	S	1.378 35	2.677 68	2.683 68.16	0.354 9	◆224052→	320	H	1.575 40	2.047 52	2.058 52.27	0.276 7
◆223601	350	S	1.417 36	1.850 47	1.859 47.22	0.276 7	◆224063→	320	N	1.575 40	2.480 63	2.491 63.27	0.315 8
◆223602→	320	N	1.417 36	1.929 49	1.938 49.23	0.276 7	◆224066→	400	N	1.575 40	2.598 66	2.609 66.27	0.315 8
◆223605	470	S	1.417 36	1.969 50	1.974 50.14	0.276 7	224068	400	N	1.575	2.677	2.681	0.354
◆223606	480	S	1.024 26	1.654 42	1.659 42.14	0.315 8	◆224100	350	S	1.575 40	2.559 65	2.565 65.15	0.394 10
◆223607XX	320	S	0.866 22	1.417 36	1.425 36.20	0.276 7	224150	350	N	1.614	2.126	2.135	0.276
◆223608←	320	S	1.417 36	2.047 52	2.055 52.20	0.394 10	◆224200	320	S	1.654 42	2.165 55	2.172 55.17	0.236 6
◆223610	350	S	1.417 36	2.126 54	2.137 54.28	0.295 7.50	◆224200S	320	S	1.654 42	2.165 55	2.172 55.17	0.236 6
◆223707XX	350	S	0.866 22	1.457 37	1.466 37.23	0.276 7	◆224205→	320	N	1.654 42	2.165 55	2.178 55.33	0.315 8
◆223750→	320	N	1.457 37	1.969 50	1.980 50.29	0.236 6	◆224207XX	320	S	0.866 22	1.654 42	1.661 42.20	0.276 7
◆223800→	320	N	1.496 38	1.969 50	1.980 50.28	0.315 8	◆224210XX	350	S	0.866 22	1.654 42	1.661 42.20	0.394 10
◆223801	320	S	1.496 38	1.969 50	1.980 50.29	0.315 8	◆224210	350	S	1.654 42	2.165 55	2.172 55.17	0.236 6
◆223802→	320	N	1.496 38	1.969 50	1.978 50.25	0.236 6	◆224215←	320	N	1.654 42	2.283 58	2.294 58.27	0.374 9.50
◆223805	250	S	1.496 38	2.244 57	1.850 47.00	0.276 7	◆224220	490	S	1.654 42	2.205 56	2.213 56.21	0.276 7
◆223807XX	350	S	0.866 22	1.496 38	1.504 38.20	0.276 7	◆224235	480	S	1.654 42	2.283 58	2.290 58.17	0.354 9
◆223808XX	320	S	0.866 22	1.496 38	1.504 38.20	0.315 8	◆224250→	350	S	1.654 42	2.441 62	2.452 62.28	0.394 10
◆223830	350	N	1.496 38	2.165 55	2.176 55.27	0.354 9	◆224252	320	S	1.654 42	2.441 62	2.452 62.28	0.276 7
◆223831→	320	N	1.496 38	2.165 55	2.176 55.27	0.354 9	◆224254	340	S	1.654 42	2.524 64.10	2.535 64.39	0.236 6
							◆224255	470	N	1.654 42	2.559 65	2.565 65.15	0.394 10

Part Number	Style	Matl	Shaft	Bore	O.D.	Width	Part Number	Style	Matl	Shaft	Bore	O.D.	Width
224266	320	S	1.654	2.598	2.609	0.394	◆225010	470	S	1.969	2.559	2.565	0.354
◆224270	350	S	1.654	2.835	2.845	0.394				50	65	65.15	9
			42	72	72.27	10	◆225020→	320	V	1.969	2.677	2.688	0.354
◆224320	470	S	1.693	2.441	2.448	0.394				50	68	68.28	9
			43	62	62.18	10	◆225030	350	S	1.969	2.835	2.846	0.315
◆224400	250	S	1.693	2.126	2.132	0.256				50	72	72.29	8
			43	54	54.15	6.50	◆225035	320	S	1.969	2.835	2.846	0.354
224450	350	N	1.732	2.323	2.332	0.268				50	72	72.29	9
◆224460→	350	X	1.732	2.362	2.373	0.276	◆225040→	320	S	1.969	2.835	2.846	0.472
			44	60	60.27	7				50	72	72.29	12
◆224462	320	S	1.732	2.441	2.452	0.315	◆225050	350	S	1.969	3.150	3.161	0.315
			44	62	62.28	8				50	80	80.29	8
◆224464←	320	N	1.732	2.441	2.452	0.394	◆225082	#	S	1.969	3.228	3.235	0.315
			44	62	62.28	10				50	82	82.18	8
◆224465→	320	S	1.732	2.559	2.570	0.433	◆225110	470	S	2.008	2.559	2.565	0.276
			44	65	65.28	11				51	65	65.15	7
◆224507XX	350	S	0.866	1.772	1.781	0.276	◆225208	320	S	2.047	2.559	2.570	0.354
			22	45	45.23	7				52	65	65.28	9
◆224520	350	S	1.772	2.362	2.373	0.315	◆225210	350	N	2.047	2.598	2.609	0.354
			45	60	60.27	8				52	66	66.27	9
◆224560	320	S	1.772	2.677	2.688	0.335	◆225220	350	S	2.047	2.677	2.683	0.256
			45	68	68.28	8.50				52	68	68.15	6.50
◆224570	350	S	1.772	2.835	2.846	0.276	◆225225	470	S	2.047	2.756	2.762	0.315
			45	72	72.29	7				52	70	70.16	8
◆224650→	320	N	1.811	2.283	2.294	0.276	◆225227	#	S	2.205	2.835	2.845	0.492
			46	58	58.27	7				56	72	72.27	12.50
◆224660→	320	H	1.811	2.362	2.373	0.276	◆225230	350	S	2.047	2.835	2.846	0.303
			46	60	60.27	7				52	72	72.29	7.70
224662	350	S	1.811	2.441	2.445	0.315	◆225275	660	S	2.047	2.953	2.957	0.295
224663→	350	N	1.811	2.480	2.491	0.300				52	75	75.11	7.50
◆224707XX	350	S	0.866	1.85	1.859	0.276	◆225278	350	N	2.047	3.071	3.082	0.354
			22	47	47.23	7				52	78	78.28	9
◆224772	480	S	1.850	2.835	2.841	0.315	◆225410	#	S	2.126	2.598	2.605	0.295
			47	72	72.16	8				54	66	66.17	7.50
◆224810	320	N	1.890	2.441	2.452	0.276	◆225420	320	S	2.126	2.835	2.844	0.394
			48	62	62.28	7				54	72	72.25	10
224815	400	N	1.890	2.913	2.925	0.394	◆225450	320	S	2.126	3.228	3.240	0.315
◆224820	320	S	1.890	2.441	2.452	0.315				54	82	82.30	8
			48	62	62.28	8	225460	320	S	2.126	3.346	3.356	0.394
◆224835→	320	N	1.890	2.677	2.688	0.433	◆225500	320	S	2.165	2.677	2.688	0.315
			48	68	68.28	11				55	68	68.28	8
◆224840→	320	S	1.890	2.677	2.688	0.433	◆225505	320	S	2.165	2.756	2.761	0.354
			48	68	68.28	11				55	70	70.13	9
◆224850	350	S	1.890	2.835	2.846	0.335	◆225530	350	S	2.165	2.835	2.844	0.315
			48	72	72.29	8.50				55	72	72.24	8
◆224865	320	S	1.890	2.559	2.570	0.354	◆225535	320	S	2.165	2.835	2.846	0.394
			48	65	65.28	9				55	72	72.29	10
◆224870	470	S	1.890	2.874	2.878	0.276	◆225540	320	S	2.047	2.835	2.846	0.295
			48	73	73.10	7				52	72	72.29	7.50
◆224872	320	S	1.890	2.835	2.846	0.335	◆225545	350	S	2.165	2.953	2.962	0.394
			48	72	72.29	8.50				55	75	75.24	10
◆224874	320	S	1.890	2.913	2.924	0.394	◆225650	320	S	2.205	2.835	2.840	0.354
			48	74	74.27	10				56	72	72.14	9
◆224979	470	N	1.929	3.110	3.114	-	◆225673	#	S	2.205	2.874	2.880	0.295
			49	79	79.10	-				56	73	73.15	7.50
◆225005	320	S	1.969	2.441	2.448	0.276	◆225678	#	S	2.205	3.071	3.082	0.295
			50	62	62.18	7				56	78	78.28	7.50
◆225008	470	S	1.969	2.441	2.446	0.354	◆225775	#	S	2.205	2.953	2.966	0.276
			50	62	62.13	9				56	75	75.33	7
◆225010	470	S	1.969	2.559	2.565	0.354	◆225874	1010	N	2.283	2.913	2.918	0.512
			50	65	65.15	9				58	74	74.12	13

Part Number	Style	Matl	Shaft	Bore	O.D.	Width	Part Number	Style	Matl	Shaft	Bore	O.D.	Width
◆225875	320	S	2.283 58	2.953 75	2.964 75.29	0.354 9	◆228020	320	S	3.150 80	4.134 105	4.145 105.28	0.512 13
◆225877	350	N	2.283 58	3.031 77	3.042 77.27	0.335 8.50	◆228030	350	S	3.150 80	4.331 110	4.342 110.29	0.394 10
◆225880	350	S	2.283 58	3.150 80	3.161 80.29	0.315 8	◆228250←	320	H	3.268 83	3.937 100	3.948 100.28	0.354 9
226001←	250	V	2.362	2.913	2.917	0.394	◆228410←	320	V	3.307 84	4.094 104	4.105 104.27	0.433 11
◆226015←	320	N	2.362 60	2.953 75	2.964 75.29	0.354 9	◆228480←	320	H	3.228 82	4.134 105	4.146 105.32	0.512 13
◆226018	350	N	2.362 60	3.071 78	3.082 78.28	0.354 9	◆228520	350	S	3.346 85	4.331 110	4.342 110.29	0.472 12
◆226150	#	S	2.402 61	2.992 76	3.003 76.28	0.276 7	◆228700←	320	H	3.425 87	3.937 100	3.948 100.28	0.315 8
◆226285	410	S	2.441 62	3.346 85	3.353 85.17	0.315 8	229004←	320	H	3.504	4.291	4.299	0.354
◆226480→	330	H	2.520 64	3.150 80	3.158 80.21	0.315 8	◆229005←	320	V	3.543 90	4.331 110	4.342 110.29	0.354 9
◆226510→	320	Y	2.559 65	3.189 81	3.200 81.28	0.276 7	◆229006←	320	H	3.543 90	4.331 110	4.342 110.29	0.354 9
◆226520	350	S	2.559 65	3.346 85	3.355 85.22	0.394 10	◆229010←	320	H	3.543 90	4.331 110	4.342 110.29	0.354 9
◆226530	350	S	2.559 65	3.543 90	3.554 90.27	0.394 10	◆229210←	320	V	3.583 91	4.331 110	4.342 110.29	0.335 8.50
◆226610	410	N	2.598 66	3.150 80	3.154 80.11	0.354 9	229520	350	S	3.740	5.118	5.129	0.472
226820	320	H	2.677	3.386	3.398	0.315	◆231002	350	S	3.937 100	4.724 120	4.730 120.13	0.472 12
226840	#	V	2.677	3.740	3.752	0.512	◆231003	350	S	3.937 100	4.921 125	4.935 125.35	0.472 12
◆227020←	320	H	2.756 70	3.465 88	3.476 88.29	0.472 12	◆231004	320	H	3.937 100	4.724 120	4.735 120.27	0.433 11
◆227040←	350	H	2.756 70	3.543 90	3.556 90.32	0.394 10	231052	320	H	4.134	4.724	4.732	0.433
◆227045←	470	H	2.756 70	3.622 92	3.633 92.28	0.335 8.50	231204	350	S	4.724	5.709	5.720	0.472
◆227235←	320	H	2.835 72	3.780 96	3.791 96.29	0.354 9	◆231250	350	S	4.921 125	5.906 150	5.920 150.37	0.472 12
227409	320	H	2.913	3.543	3.549	0.394	231402	350	S	5.512	6.299	6.310	0.512
◆227410→	320	H	2.913 74	3.858 98	3.869 98.27	0.472 12	239128	#	S	1.496	2.047	2.055	0.354
◆227530	350	S	2.953 75	3.740 95	3.751 95.28	0.394 10	239129	#	S	2.874	3.386	3.397	0.197
◆227540	320	S	2.953 75	3.937 100	3.948 100.28	0.394 10	◆239134	#	S	1.457 37	3.071 78	3.083 78.30	0.472 12
◆227550←	320	H	2.953 75	3.937 100	3.948 100.28	0.512 13	◆239146←	480	S	1.496 38	2.126 54	2.137 54.28	0.315 8
◆227610→	320	H	2.992 76	3.858 98	3.869 98.27	0.472 12	◆239201	320	S	1.575 40	2.047 52	2.058 52.27	0.591 15
◆228005←	320	V	3.150 80	3.780 96	3.791 96.29	0.354 9	240009	240	S	0.625	1.124	1.135	0.175
◆228008←	320	X	3.150 80	3.858 98	3.869 98.27	0.394 10	240023	240	S	0.625	1.375	1.385	0.175
◆228009←	320	H	3.150 80	3.937 100	3.948 100.28	0.394 10	240119	240	S	0.500	0.999	1.010	0.175
◆228010←	320	H	3.150 80	3.937 100	3.948 100.28	0.512 13	240151	240	S	1.125	1.561	1.572	0.187
◆228012	350	S	3.150 80	3.937 100	3.948 100.28	0.394 10	240215	240	S	0.875	1.624	1.634	0.187
◆228015→	320	H	3.150 80	3.937 100	3.948 100.28	0.512 13	240319	240	S	1.500	2.000	2.010	0.187
							240356	240	S	1.250	1.686	1.691	0.188
							240385	240	S	0.375	0.750	0.760	0.175
							240414	240	S	1.000	1.437	1.447	0.187
							240435	240	S	0.250	0.750	0.760	0.175
							240457	240	S	0.984	1.828	1.838	0.187
							240462	240	S	1.000	1.936	1.948	0.187
							240470	240	S	0.437	0.875	0.885	0.175

Part Number	Style	Matl	Shaft	Bore	O.D.	Width	Part Number	Style	Matl	Shaft	Bore	O.D.	Width
240698	240	S	0.312	0.625	0.635	0.175	◆254808XX	320	S	0.984	1.89	1.898	0.315
240716	240	S	1.312	1.752	1.760	0.187				25	48	48.20	8
240731	240	S	1.000	1.250	1.256	0.126	◆255010XX	350	S	0.984	1.969	1.98	0.394
										25	50	50.28	10
240733	240	S	0.874	1.125	1.131	0.125	◆255207XX	350	S	0.984	2.047	2.058	0.276
240735	240	S	0.750	1.000	1.006	0.126				25	52	52.27	7
240736	240	S	1.250	1.499	1.509	0.156	◆255208XX	350	S	0.984	2.047	2.055	0.315
240816	240	S	0.750	1.062	1.071	0.188				25	52	52.20	8
240949	240	S	1.250	1.250	1.838	0.187	◆255210XX	350	S	0.984	2.047	2.055	0.394
										25	52	52.20	10
◆243507XX	350	S	0.945	1.378	1.387	0.276	◆256210XX	320	S	0.984	2.441	2.452	0.394
			24	35	35.23	7				25	62	62.28	10
◆243707XX	350	S	0.945	1.457	1.466	0.276	◆263707XX	320	S	1.024	1.457	1.465	0.276
			24	37	37.23	7				26	37	37.20	7
◆243807XX	320	S	0.945	1.496	1.504	0.276							
			24	38	38.20	7	◆263805XX	320	S	1.024	1.496	1.504	0.197
◆244007XX	350	S	0.945	1.575	1.584	0.276				26	38	38.20	5
			24	40	40.23	7	◆264007XX	320	S	1.024	1.575	1.583	0.276
◆244207XX	320	S	0.945	1.645	1.661	0.276				26	40	40.20	7
			24	42	42.20	7	◆264207XX	320	S	1.024	1.654	1.661	0.276
										26	42	42.20	7
◆244210XX	320	S	0.945	1.654	1.663	0.394	◆264210XX	350	S	1.024	1.654	1.663	0.394
			24	42	42.25	10				26	42	42.23	10
◆244707XX	350	S	0.945	1.85	1.859	0.276	◆264707XX	350	S	1.024	1.85	1.859	0.276
			24	47	47.23	7				26	47	47.23	7
◆245207XX	320	S	0.945	2.047	2.055	0.276							
			24	52	52.20	7	◆264807XX	320	S	1.024	1.89	1.899	0.276
251511	250	S	1.250	1.625	1.634	0.188				26	48	48.23	7
252277	250	S	1.000	1.375	1.381	0.252	◆265208XX	320	S	1.024	2.047	2.055	0.315
										26	52	52.20	8
252450	250	S	0.750	1.311	1.317	0.311	◆273707XX	350	S	1.063	1.457	1.463	0.276
253099	250	S	1.500	1.874	1.879	0.250				27	37	37.15	7
◆253506XX	320	S	0.984	1.378	1.386	0.236	◆274210XX	350	S	1.063	1.654	1.663	0.394
			25	35	35.20	6				27	42	42.23	10
◆253506XX	320	S	0.984	1.378	1.388	0.276	◆274308XX	320	S	1.063	1.693	1.701	0.315
			25	35	35.25	7				27	43	43.20	8
◆253607XX	320	S	0.984	1.417	1.426	0.276							
			25	36	36.23	7	◆274508XX	350	S	1.063	1.772	1.781	0.315
										27	45	45.25	8
◆253608XX	350	S	0.984	1.417	1.426	0.315	◆274710XX	350	S	1.063	1.85	1.859	0.394
			25	36	36.22	8				27	47	47.23	10
◆253707XX	320	S	0.984	1.457	1.465	0.276	◆275208XX	350	S	1.063	2.047	2.055	0.315
			25	37	37.20	7				27	52	52.20	8
253747	250	S	0.625	0.875	0.880	0.125	◆283807XX	350	S	1.102	1.496	1.505	0.276
◆253807XX	350	S	0.984	1.496	1.505	0.276				28	38	38.23	7
			25	38	38.23	7	◆284007XX	350	S	1.102	1.575	1.585	0.276
◆254007XX	350	S	0.984	1.575	1.583	0.276				28	40	40.26	7
			25	40	40.22	7							
◆254206XX	350	S	0.984	1.654	1.661	0.236	◆284008XX	320	S	1.102	1.575	1.583	0.315
			25	42	42.20	6				28	40	40.20	8
◆254208XX	320	S	0.984	1.654	1.661	0.315	◆284208XX	350	S	1.102	1.654	1.663	0.315
			25	42	42.20	8				28	42	42.23	8
◆254210XX	350	S	0.984	1.654	1.665	0.394	◆284406XX	320	N	1.102	1.732	1.741	0.236
			25	42	42.28	10				28	44	44.23	6
254270	250	S	0.750	1.124	1.130	0.189	◆284508XX	320	S	1.102	1.772	1.78	0.315
254287	250	S	0.875	1.250	1.256	0.189				28	45	45.20	8
							◆284707XX	350	S	1.102	1.85	1.859	0.276
										28	47	47.22	7
◆254508XX	350	S	0.984	1.772	1.781	0.315	◆284808XX	320	S	1.102	1.89	1.898	0.315
			25	45	45.23	8				28	48	48.20	8
◆254607XX	320	S	0.984	1.811	1.819	0.276	◆285207XX	350	S	1.102	2.047	2.056	0.276
			25	46	46.20	7				28	52	52.23	7
◆254707XX	350	S	0.984	1.85	1.859	0.276	291099	290	F	1.625	2.562	2.566	0.375
			25	47	47.23	7	291295	290	F	1.840	2.400	2.404	0.235

Part Number	Style	Matl	Shaft	Bore	O.D.	Width	Part Number	Style	Matl	Shaft	Bore	O.D.	Width
292594	290	F	2.000	2.635	2.639	0.235	321460	320	S	1.781	2.258	2.269	0.374
296470	290	F	3.250	4.249	4.254	0.375	321516	320	S	1.000	2.441	2.447	0.375
◆304007XX	350	S	1.181 30	1.575 40	1.584 40.23	0.276 7	322353	320	S	1.250	1.686	1.695	0.252
◆304207XX	350	S	1.181 30	1.654 42	1.661 42.20	0.276 7	322373	320	S	1.500	2.250	2.260	0.312
◆304407XX	250	S	1.181 30	1.732 44	1.743 44.28	0.276 7	323119	320	S	1.750	2.715	2.721	0.437
◆304505XX	320	S	1.181 30	1.772 45	1.78 45.22	0.197 5	323125	320	S	1.375	2.717	2.723	0.375
◆304508XX	320	S	1.181 30	1.772 45	1.78 45.20	0.315 8	323126	320	S	1.250	1.687	1.696	0.313
◆304607XX	320	S	1.181 30	1.811 46	1.819 46.20	0.276 7	323133	320	S	1.125	1.781	1.790	0.409
◆304707XX	350	S	1.181 30	1.85 47	1.86 47.25	0.276 7	323138	320	S	1.375	1.828	1.834	0.250
◆304808XX	350	S	1.181 30	1.89 48	1.901 48.28	0.315 8	324112	320	S	0.500	1.156	1.166	0.250
◆305007XX	350	S	1.181 30	1.969 50	1.978 50.23	0.276 7	324204	320	V	1.535	2.244	2.259	0.380
◆305008XX	480	S	1.181 30	1.969 50	1.976 50.20	0.315 8	◆324207XX	350	S	1.26 32	1.654 42	1.661 42.20	0.276 7
◆305207XX	350	S	1.181 30	2.047 52	2.056 52.23	0.276 7	◆324208XX	320	S	1.26 32	1.654 42	1.661 42.20	0.315 8
◆305510XX	350	S	1.181 30	2.165 55	2.176 55.28	0.394 10	◆324307XX	320	S	1.26 32	1.693 43	1.701 43.20	0.276 7
◆305608XX	350	S	1.181 30	2.205 56	2.213 56.20	0.315 8	◆324507XX	320	S	1.26 32	1.772 45	1.781 45.23	0.276 7
◆306207XX	350	S	1.181 30	2.441 62	2.452 62.28	0.276 7	◆324606XX	320	S	1.26 32	1.811 46	1.82 46.23	0.236 6
◆306207XX	350	S	1.181 30	2.441 62	2.452 62.08	0.276 7	◆324707XX	350	S	1.26 32	1.85 47	1.859 47.23	0.276 7
◆307210XX	350	S	1.181 30	2.835 72	2.845 72.27	0.394 10	◆324808XX	350	S	1.26 32	1.89 48	1.898 48.20	0.315 8
310841	310	S	2.750	3.125	3.130	0.187	324939	320	S	1.625	2.116	2.127	0.312
311189	310	S	0.375	0.687	0.693	0.156	324941	320	S	1.750	2.565	2.571	0.313
312140	310	S	1.125	1.502	1.506	0.250	◆325008XX	350	S	1.26 32	1.969 50	1.978 50.23	0.315 8
312196	310	S	0.500	0.843	0.848	0.250	◆325207XX	350	S	1.26 32	2.047 52	2.058 52.28	0.276 7
312518	310	S	0.750	1.000	1.006	0.126	◆325410XX	320	S	1.26 32	2.126 54	2.135 54.23	0.394 10
313842	310	S	1.125	1.438	1.444	0.215	◆325610XX	350	S	1.26 32	2.205 56	2.216 56.28	0.394 10
314259	310	S	0.563	0.875	0.881	0.188	◆325808XX	320	S	1.26 32	2.283 58	2.291 58.20	0.315 8
314267N	310	N	0.625	1.000	1.006	0.125	◆326008XX	320	S	1.26 32	2.362 60	2.37 60.20	0.315 8
◆314408XX	320	S	1.22 31	1.732 44	1.74 44.20	0.315 8	◆326010XX	480	S	1.26 32	2.362 60	2.37 60.20	0.394 10
320249	320	V	1.378	1.890	1.898	0.299	◆326208XX	320	S	1.26 32	2.441 62	2.449 62.20	0.315 8
320259→	320	V	1.998	2.878	2.884	0.374	◆327208XX	320	S	1.26 32	2.835 72	2.843 72.20	0.315 8
320348	320	V	1.260	1.772	1.780	0.236	327215	320	S	4.000	4.998	5.006	0.468
320457	320	S	0.472	1.000	1.006	0.375	327303	320	S	4.500	5.251	5.259	0.437
◆320564→	320	V	1.772 45	2.677 68	2.688 68.28	0.472 12	327878	320	S	1.312	-	-	0.350
◆320583→	320	S	1.693 43	2.362 60	2.373 60.27	0.354 9	◆327995←	320	V	2.992 76	3.622 92	3.633 92.28	0.394 10
◆320595←	320	S	1.142 29	1.772 45	1.781 45.24	0.315 8	330385	330	S	0.375	0.750	0.756	0.252
320691	320	V	3.228	3.918	3.928	0.500	330414	330	S	1.000	1.437	1.441	0.250
321267	320	S	0.875	1.375	1.381	0.250	330663	330	S	1.375	1.874	1.880	0.311
							330699	330	S	0.500	0.875	0.879	0.187
							330749V	330	V	1.562	2.062	2.066	0.250
							331107N	330	H	2.000	2.742	2.748	0.375

Part Number	Style	Matl	Shaft	Bore	O.D.	Width	Part Number	Style	Matl	Shaft	Bore	O.D.	Width
331173	330	S	0.701	1.160	1.164	0.250	342613	340	S	0.500	0.874	0.883	0.125
331227H	330	H	1.875	2.623	2.629	0.375	342805	340	S	0.500	0.687	0.696	0.094
331228H→	750	N	1.500	2.250	2.256	0.313	343098	340	S	1.000	1.247	1.253	0.187
331301N	330	N	2.000	2.562	2.566	0.528	343099	340	S	1.500	1.874	1.880	0.250
332062→	330	S	1.868	2.518	2.524	0.469	343101	340	S	0.437	0.625	0.634	0.126
332134	330	S	2.062	2.561	2.565	0.312	343104	340	S	0.250	0.500	0.509	0.125
332271N	330	N	2.328	3.000	3.006	0.375	343105	340	S	0.625	0.937	0.943	0.188
◆334111	330	S	1.693	2.126	2.132	0.295	343123	340	S	1.000	1.563	1.569	0.187
			43	54	54.15	7.50	343185	340	S	0.750	1.125	1.131	0.156
◆335012XX	320	S	1.299	1.969	1.978	0.472	343186	340	S	1.250	1.500	1.509	0.125
			33	50	50.25	12	◆344508XX	320	S	1.339	1.772	1.78	0.315
◆335206XX	320	S	1.299	2.047	2.057	0.236				34	45	45.20	8
			33	52	52.25	6	345035	340	S	4.000	4.999	5.008	0.312
335924N	330	N	4.000	4.562	4.568	0.375	345146	340	S	3.500	4.499	4.508	0.250
							◆345208XX	320	S	1.339	2.047	2.058	0.315
										34	52	52.28	8
337426N	330	N	9.250	10.250	10.258	0.500	◆345409XX	350	S	1.339	2.126	2.134	0.354
340009	340	S	0.625	1.124	1.133	0.250				34	54	54.20	9
340009S	340	S	0.625	1.124	1.133	0.250	345448	340	S	5.250	6.250	6.264	0.251
340120	340	S	1.000	1.500	1.509	0.252	◆345509XX	320	S	1.339	2.165	2.173	0.354
340136	340	S	1.500	2.250	2.258	0.250				34	55	55.20	9
							◆346210XX	350	S	1.339	2.441	2.448	0.394
340151	340	S	1.125	1.561	1.567	0.250				34	62	62.18	10
340210	340	S	1.062	1.499	1.507	0.250	350156	350	S	0.375	0.875	0.884	0.311
340356	340	S	1.250	1.685	1.694	0.188							
340385	340	S	0.375	0.750	0.756	0.250	350364	350	S	0.312	0.750	0.759	0.252
340387	340	S	0.625	0.812	0.821	0.094	350394	350	S	1.500	2.125	2.131	0.437
							350414	350	S	1.000	1.437	1.443	0.252
340400	340	S	1.750	2.250	2.258	0.250	350435	350	S	0.250	0.750	0.759	0.244
340413	340	S	0.875	1.308	1.317	0.250	350567	350	S	0.875	1.375	1.384	0.252
340469	340	S	0.656	1.250	1.258	0.250							
340483	340	S	0.874	1.250	1.259	0.251	◆350572	350	V	1.575	2.835	2.844	0.276
340495	340	S	0.750	1.124	1.133	0.189				40	72	72.24	7
							◆350609←	350	N	1.732	2.677	2.688	0.315
340724	340	S	0.614	0.999	1.006	0.250				44	68	68.28	8
340771	340	S	0.490	0.875	0.883	0.250	350679	350	S	0.750	1.250	1.259	0.313
340787	340	S	0.937	1.375	1.383	0.250	350877	350	S	0.875	1.575	1.581	0.250
340797	340	S	0.593	0.935	0.943	0.175	350909	350	S	1.000	1.500	1.509	0.311
340815	340	S	1.125	1.500	1.509	0.250							
							350936	350	S	1.875	2.561	2.567	0.313
340817	340	S	1.187	1.627	1.635	0.250	350954	350	S	0.750	1.250	1.259	0.252
340823	340	S	1.875	2.502	2.511	0.250	350974	350	S	1.125	1.850	1.859	0.311
340826	340	S	0.312	0.500	0.509	0.125	351028	350	S	0.490	1.122	1.132	0.265
340827	340	S	0.375	0.562	0.571	0.125	351255	350	S	0.625	1.374	1.383	0.251
340835	340	S	1.125	1.374	1.383	0.125							
							351267	350	S	0.875	1.375	1.384	0.252
340847	340	S	0.500	0.750	0.759	0.125	351466	350	S	0.625	1.125	1.134	0.252
340849	340	S	0.625	0.875	0.881	0.126	351487	350	S	0.625	1.000	1.009	0.252
340850	340	S	0.875	1.187	1.196	0.188	351646	350	S	0.875	1.624	1.630	0.250
340853	340	S	1.375	1.750	1.756	0.187	352354	350	S	1.375	1.875	1.884	0.250
340872	340	S	0.156	0.500	0.504	0.187							
							352444	350	S	1.436	2.062	2.073	0.250
340900	340	S	2.093	2.716	2.725	0.250	352521	350	S	1.500	2.000	2.011	0.252
340927	340	S	1.562	2.096	2.102	0.250	352541	350	S	2.000	2.502	2.513	0.252
340930	340	S	1.438	2.000	2.011	0.125	352560	350	S	1.125	1.561	1.567	0.250
341022	340	S	2.250	2.625	2.636	0.187	352637	350	S	2.250	3.035	3.046	0.374
342517	340	S	1.000	1.312	1.318	0.126							
							353120	350	S	1.875	2.397	2.408	0.250
342518	340	S	0.750	1.000	1.009	0.125							

Part Number	Style	Matl	Shaft	Bore	O.D.	Width	Part Number	Style	Matl	Shaft	Bore	O.D.	Width
353131	350	S	0.812	1.375	1.381	0.250	◆364707XX	350	S	1.417 36	1.85 47	1.858 47.20	0.276 7
353132	350	S	0.875	1.308	1.317	0.250	◆365007XX	470	S	1.417 36	1.969 50	1.972 50.08	0.276 7
353135	350	S	1.250	1.686	1.692	0.219	365008	360	S	2.687	3.876	3.876	0.250
353137	350	S	1.281	2.000	2.006	0.250	◆365207XX	350	S	1.417 36	2.047 52	2.055 52.20	0.276 7
353141	350	S	1.687	2.279	2.285	0.250	◆365408XX	350	S	1.417 36	2.126 54	2.134 54.20	0.315 8
353890	350	S	2.375	-	3.375	0.510	◆365610XX	350	S	1.417 36	2.205 56	2.215 56.25	0.394 10
354040	350	T	1.750	2.500	2.508	0.375	◆365808XX	470	S	1.417 36	2.283 58	2.293 58.25	0.315 8
354041	350	T	1.771	2.622	2.628	0.500	◆365812XX	350	S	1.417 36	2.283 58	2.293 58.23	0.472 12
◆354507XX	350	S	1.378 35	1.772 45	1.778 45.15	0.276 7	◆366007XX	320	S	1.417 36	2.362 60	2.37 60.20	0.276 7
◆354707XX	350	S	1.378 35	1.85 47	1.859 47.23	0.276 7	◆366207XX	320	S	1.417 36	2.441 62	2.452 62.28	0.276 7
◆354808XX	320	S	1.378 35	1.89 48	1.898 48.20	0.315 8	◆366810XX	350	S	1.417 36	2.677 68	2.688 68.28	0.394 10
◆355007XX	350	S	1.378 35	1.969 50	1.976 50.20	0.276 7	◆375208XX	350	S	1.457 37	2.047 52	2.058 52.28	0.315 8
◆355008XX	350	S	1.378 35	1.969 50	1.9778 50.24	0.315 8	◆385007XX	350	S	1.496 38	1.969 50	1.978 50.25	0.276 7
355200	350	S	4.500	5.500	5.514	0.500	◆385207XX	320	S	1.496 38	2.047 52	2.055 52.20	0.276 7
◆355207XX	350	S	1.378 35	2.047 52	2.055 52.20	0.276 7	◆385308XX	320	S	1.496 38	2.087 53	2.094 53.20	0.315 8
◆355208XX	330	S	1.378 35	2.047 52	2.052 52.13	0.315 8	◆385407XX	480	S	1.496 38	2.126 54	2.133 54.18	0.276 7
◆355408XX	350	S	1.378 35	2.126 54	2.134 54.20	0.315 8	◆385410XX	320	S	1.496 38	2.126 54	2.133 54.18	0.394 10
◆355508XX	470	S	1.378 35	2.165 55	2.174 55.10	0.315 8	◆385507XX	350	N	1.496 38	2.165 55	2.174 55.23	0.276 7
◆355511XX	320	S	1.378 35	2.165 55	2.174 55.23	0.433 11	◆385610XX	350	S	1.496 38	2.205 56	2.216 56.28	0.394 10
355526	350	S	3.000	3.876	3.887	0.500	◆385808XX	470	S	1.496 38	2.283 58	2.288 58.11	0.315 8
◆355608XX	350	S	1.378 35	2.205 56	2.213 56.20	0.315 8	◆386008XX	320	S	1.496 38	2.362 60	2.37 60.20	0.315 8
◆355610XX	320	S	1.378 35	2.205 56	2.215 56.27	0.394 10	◆386010XX	350	S	1.496 38	2.362 60	2.376 60.35	0.394 10
355669	350	S	3.040	3.937	3.946	0.250	◆386207XX	350	S	1.496 38	2.441 62	2.452 62.28	0.276 7
355732	350	S	2.500	4.250	4.260	0.500	◆386508XX	320	S	1.496 38	2.559 65	2.567 65.20	0.315 8
◆355810XX	350	S	1.378 35	2.283 58	2.294 58.28	0.394 10	◆386808XX	320	S	1.496 38	2.677 68	2.685 68.20	0.315 8
◆356010XX	350	S	1.378 35	2.362 60	2.371 60.23	0.394 10	◆386810XX	320	S	1.496 38	2.677 68	2.685 68.20	0.394 10
◆356207XX	350	S	1.378 35	2.441 62	2.452 62.28	0.276 7	◆387010XX	350	S	1.496 38	2.756 70	2.764 70.20	0.394 10
◆356210XX	350	S	1.378 35	2.441 62	2.449 62.20	0.394 10	◆387210XX	350	S	1.496 38	2.835 72	2.843 72.20	0.394 10
◆356408XX	470	N	1.378 35	2.52 64	2.525 64.13	0.315 8	◆387408XX	320	S	1.496 38	2.913 74	2.921 74.20	0.315 8
◆356508XX	320	S	1.378 35	2.559 65	2.567 65.20	0.315 8	◆387411XX	320	N	1.496 38	2.913 74	2.921 74.20	0.433 11
◆356510XX	320	S	1.378 35	2.559 65	2.567 65.20	0.394 10	◆405008XX	350	S	1.575 40	1.969 50	1.976 50.20	0.315 8
◆357008XX	320	S	1.378 35	2.756 70	2.764 70.20	0.315 8							
◆357210XX	350	S	1.378 35	2.835 72	2.846 72.28	0.394 10							
357262H←	350	S	5.250	-	-	0.500							
◆358008XX	320	S	1.378 35	3.15 80	3.15 80.20	0.315 8							

Part Number	Style	Matl	Shaft	Bore	O.D.	Width	Part Number	Style	Matl	Shaft	Bore	O.D.	Width
◆405207XX	350	S	1.575 40	2.047 52	2.057 52.25	0.276 7	410520	410	S	2.250	3.000	3.006	0.374
◆405406XX	470	S	1.575 40	2.126 54	2.134 54.20	0.217 5.50	410524	410	S	1.875	3.371	3.376	0.468
◆405506XX	350	S	1.575 40	2.165 55	2.173 55.20	0.256 6.50	410686N	410	N	2.375	3.483	3.490	0.500
◆405508XX	350	S	1.575 40	2.165 55	2.176 55.28	0.315 8	410694	410	S	2.312	3.350	3.355	0.375
◆405607XX	320	S	1.575 40	2.205 56	2.213 56.20	0.276 7	410708	410	S	2.625	3.371	3.378	0.438
◆405710XX	320	S	1.575 40	2.244 57	2.252 57.20	0.394 10	410737	410	S	2.250	3.189	3.194	0.437
◆405808XX	350	S	1.575 40	2.283 58	2.291 58.20	0.315 8	410752	410	S	2.500	3.251	3.258	0.374
◆405810XX	320	S	1.575 40	2.283 58	2.294 58.28	0.394 10	410791V	410	V	0.625	1.124	1.128	0.312
◆406010XX	350	S	1.575 40	2.362 60	2.37 60.20		410825	410	S	2.375	3.623	3.628	0.375
◆406207XX	350	S	1.575 40	2.441 62	2.449 62.20	0.276 7	410867N	410	N	2.125	2.875	2.881	0.437
◆406208XX	320	S	1.575 40	2.441 62	2.451 62.25	0.315 8	410922N	410	N	2.125	3.371	3.376	0.468
◆406212XX	350	S	1.575 40	2.441 62	2.451 62.25	0.563 11.50	410987	410	S	2.375	3.483	3.490	0.500
◆406510XX	350	S	1.575 40	2.559 65	2.57 65.28	0.394 10	411160V	410	V	2.312	3.000	3.005	0.500
◆406808XX	350	S	1.575 40	2.677 68	2.709 68.80	0.315 8	411245	410	S	2.437	3.500	3.505	0.375
◆406812XX	350	S	1.575 40	2.677 68	2.687 68.25	0.472 12	411253	410	S	2.250	3.350	3.355	0.375
◆407008XX	320	S	1.575 40	2.756 70	2.764 70.20	0.315 8	411275	410	V	3.250	4.249	4.254	0.468
◆407207XX	350	S	1.575 40	2.835 72	2.848 72.35	0.276 7	411330	410	S	2.598	3.481	3.488	0.438
◆407808XX	320	S	1.575 40	3.071 78	3.102 78.80	0.315 8	411330N	410	N	2.598	3.481	3.488	0.438
◆407810XX	350	S	1.575 40	3.071 78	3.079 78.20	0.394 10	411348	410	S	2.812	4.249	4.254	0.468
◆408010XX	350	S	1.575 40	3.15 80	3.161 80.28	0.394 10	411376	410	S	2.250	3.500	3.505	0.375
◆409008XX	350	S	1.575 40	3.543 90	3.551 90.20	0.315 8	411394	410	S	2.312	3.251	3.256	0.375
410059	410	S	1.500	2.374	2.380	0.311	411500	410	S	2.437	3.350	3.355	0.375
410085	410	S	2.000	2.995	3.002	0.500	412015V	410	V	2.125	3.000	3.006	0.374
410085N	410	N	2.000	2.995	3.002	0.500	412027	410	S	2.000	3.251	3.256	0.437
410101N	410	N	2.375	3.350	3.355	0.468	412028	410	S	2.000	3.350	3.355	0.468
410102	410	S	2.000	3.371	3.378	0.469	412038N	410	N	2.375	3.251	3.256	0.437
410119	410	S	0.500	0.999	1.005	0.252	412040	410	S	2.438	3.251	3.258	0.438
410135	410	S	1.375	2.125	2.131	0.311	412119	410	S	2.375	3.350	3.355	0.375
410154	410	S	1.687	2.502	2.508	0.311	412473	410	S	3.374	4.375	4.382	0.374
410163	410	S	1.250	2.000	2.006	0.438	412725	410	S	2.000	3.150	3.155	0.375
410183N	410	N	1.750	2.750	2.756	0.311	412798N	410	N	2.062	3.000	3.005	0.437
410190	410	S	1.500	2.561	2.565	0.500	412861	410	S	2.375	3.543	3.550	0.500
410308	410	S	2.125	3.061	3.067	0.500	412871	410	S	2.625	3.350	3.355	0.375
410312N	410	N	2.125	3.125	3.130	0.500	412920	410	S	2.250	3.371	3.378	0.374
410316	410	S	2.250	3.251	3.258	0.500	412920V	410	V	2.250	3.371	3.378	0.374
410496	410	S	2.500	3.350	3.355	0.468	412943	410	S	2.187	3.350	3.355	0.375
410519	410	S	2.500	3.251	3.258	0.374	413246	410	S	2.375	3.251	3.258	0.374
							413247	410	S	2.375	3.371	3.378	0.375
							413248	410	S	2.625	3.371	3.378	0.438
							413469	410	S	2.125	3.350	3.355	0.375
							413470	410	S	2.125	3.371	3.372	0.375
							413472	410	S	2.187	3.371	3.376	0.375
							413478	410	S	2.437	3.371	3.376	0.375
							413479	410	S	2.562	3.481	3.486	0.375
							◆413818	410	S	1.969 50	2.756 70	2.760 70.10	0.276 7
							414045	410	S	1.875	2.782	2.786	0.500
							414268	410	S	1.625	3.000	3.004	0.312
							415001	410	S	2.500	3.543	3.548	0.500
							415001N	410	N	2.500	3.543	3.548	0.500

Part Number	Style	Matl	Shaft	Bore	O.D.	Width	Part Number	Style	Matl	Shaft	Bore	O.D.	Width
415003	410	S	2.625	3.623	3.630	0.469	415192N	410	N	4.000	5.251	5.256	0.468
415004	410	S	2.750	3.751	3.758	0.374	415196	410	S	4.250	5.375	5.383	0.500
415007	410	S	2.625	3.876	3.881	0.468	415213N	410	N	4.750	5.999	6.007	0.625
415009	410	S	2.750	3.876	3.883	0.438	415219	410	S	9.250	11.250	11.260	0.750
415009N	410	N	2.750	3.876	3.883	0.438	415227	410	S	10.500	12.500	12.508	1.000
415012V	410	V	2.937	4.003	4.008	0.468	415234	410	S	2.250	3.623	3.630	0.469
415013	410	S	3.000	4.003	4.010	0.437	415248N	410	N	2.375	3.543	3.548	0.500
415013N	410	N	3.000	4.003	4.010	0.437	415254	410	S	2.250	4.003	4.010	0.469
415016N	410	N	3.125	4.249	4.254	0.625	415259	410	S	2.250	3.750	3.757	0.500
415021	410	S	3.125	4.999	5.004	0.468	415263	410	S	3.937	5.376	5.384	0.500
415023	410	S	3.250	4.999	5.004	0.468	415272N	410	N	2.750	4.003	4.010	0.438
415025	410	S	3.375	4.999	5.004	0.468	415281N	410	N	3.000	3.751	3.758	0.500
415027H	410	H	3.500	4.999	5.004	0.468	415284	410	S	4.687	5.751	5.756	0.500
415027N	410	N	3.500	4.999	5.004	0.468	415294	410	S	6.500	7.500	7.508	0.562
415034	410	S	3.937	4.999	5.004	0.468	415295	410	S	4.187	4.999	5.004	0.468
415035	410	S	4.000	4.998	5.006	0.468	415302	410	S	2.562	3.500	3.505	0.375
415036	410	S	4.000	5.501	5.506	0.562	415303	410	S	2.875	3.623	3.630	0.374
415041	410	S	4.000	5.751	5.756	0.562	415304	410	S	3.250	4.249	4.256	0.469
415043	410	S	4.125	5.751	5.756	0.562	415317	410	S	7.375	9.000	9.010	0.750
415045	410	S	4.250	5.751	5.756	0.562	415322	410	S	2.750	3.543	3.550	0.438
415047	410	S	4.375	5.751	5.756	0.562	415327	410	S	6.750	8.000	8.009	0.625
415052	410	S	8.000	10.125	10.133	0.750	415349	410	S	2.125	3.543	3.550	0.500
415058	410	S	4.250	6.250	6.256	0.562	415350	410	S	2.187	3.623	3.628	0.468
415060	410	S	4.375	6.250	6.256	0.562	415351	410	S	4.500	6.250	6.256	0.500
415064	410	S	4.625	6.250	6.256	0.562	415371	410	S	4.625	5.751	5.756	0.562
415066	410	S	4.750	6.251	6.259	0.563	415379	410	S	3.750	4.750	4.758	0.500
415072	410	S	6.000	7.500	7.508	0.562	415389	410	S	3.625	4.499	4.504	0.468
415074	410	S	6.125	7.500	7.508	0.562	415389N	410	N	3.625	4.499	4.504	0.468
415076	410	S	11.500	13.500	13.508	0.750	415394	410	S	3.125	5.251	5.256	0.468
415077	410	S	11.500	13.000	13.010	0.750	415425	410	S	4.375	5.376	5.381	0.500
415082	410	S	2.500	3.876	3.881	0.468	415436	410	S	3.625	5.751	5.756	0.562
415082N	410	N	2.500	3.876	3.881	0.468	415437	410	S	3.500	4.750	4.758	0.500
415085	410	S	3.313	4.500	4.507	0.438	415442	410	S	3.375	4.125	4.130	0.375
415086N	410	N	3.000	4.249	4.254	0.468	415447	410	S	5.750	6.624	6.632	0.625
415088	410	S	3.000	4.501	4.508	0.433	415449	410	S	2.500	3.500	3.507	0.374
415090	410	S	9.000	11.000	11.008	0.750	415449V	410	V	2.500	3.500	3.507	0.374
415098N	410	N	2.562	3.500	3.505	0.500	415458	410	S	2.625	3.623	3.630	0.374
415116	410	S	7.250	8.750	8.759	0.750	415458V	410	V	2.625	3.623	3.630	0.374
415124	410	S	8.250	10.250	10.260	0.750	415482	410	S	11.000	13.000	13.010	0.750
415128	410	S	8.750	10.750	10.758	0.750	415483	410	S	2.625	3.500	3.507	0.374
415137	410	S	3.250	4.500	4.507	0.438	415498	410	S	3.562	4.499	4.504	0.468
415138	410	S	4.750	5.750	5.758	0.500	◆415507XX	320	S	1.614 41	2.165 55	2.177 55.29	0.276 7
415142	410	S	4.125	5.251	5.256	0.468	415551	410	S	7.500	9.000	9.010	0.750
415146	410	S	3.500	4.499	4.504	0.468	415551V	410	V	7.500	9.000	9.010	0.750
415147	410	S	2.500	3.500	3.507	0.500	415559	410	S	3.500	5.251	5.256	0.468
415147N	410	N	2.500	3.500	3.507	0.500	415563	410	S	3.250	4.003	4.008	0.468
415150	410	S	3.750	5.251	5.256	0.468	415577	410	S	3.250	4.723	4.729	0.468
415156N	410	N	3.125	4.125	4.130	0.562	◆415607XX	350	S	1.614 41	2.205 56	2.215 56.25	0.276 7
415164N	410	N	3.375	4.376	4.381	0.625							
415187	410	S	4.000	4.876	4.881	0.625							

Part Number	Style	Matl	Shaft	Bore	O.D.	Width	Part Number	Style	Matl	Shaft	Bore	O.D.	Width
415610	410	S	5.500	7.000	7.007	0.625	416112	410	S	5.375	7.874	7.881	0.750
415627	410	S	2.000	3.500	3.505	0.500	416125	410	S	3.625	4.999	5.007	0.500
415645	410	S	5.250	6.500	6.507	0.562	416127	410	S	3.750	5.376	5.381	0.500
415656	410	S	8.000	9.000	9.010	0.750	416130	410	S	4.000	5.375	5.383	0.500
415683	410	S	6.000	7.000	7.008	0.500	416135	410	S	4.250	5.625	5.633	0.500
415697	410	S	3.875	5.125	5.133	0.500	416137	410	S	4.250	5.999	6.005	0.500
415711	410	S	3.562	4.625	4.631	0.500	416144	410	S	4.312	5.999	6.005	0.500
415725	410	S	5.000	6.001	6.009	0.500	416147	410	S	4.375	5.626	5.631	0.500
415832	410	S	3.625	5.375	5.381	0.500	416149	410	S	4.375	5.999	6.005	0.500
415836	410	S	3.000	4.003	4.010	0.437	416153	410	S	4.500	5.625	5.631	0.500
415854	410	S	6.250	7.875	7.884	0.750	416154	410	S	4.500	6.000	6.014	0.500
415857	410	S	2.375	3.601	3.608	0.437	416156	410	S	4.625	5.625	5.631	0.500
415867	410	S	7.500	8.500	8.510	0.625	416158	410	S	4.625	5.999	6.007	0.500
415871	410	S	9.375	11.375	11.385	0.750	416163	410	S	4.812	5.999	6.007	0.500
415876	410	S	7.000	9.313	9.321	0.625	416167	410	S	4.875	5.999	6.007	0.500
415876V	410	V	7.000	9.313	9.321	0.625	416191	410	S	5.500	7.125	7.133	0.625
415894	410	S	3.375	4.376	4.383	0.500	416229	410	S	6.500	8.000	8.009	0.625
415897	410	S	5.000	6.877	6.884	0.625	416257	410	S	9.250	11.000	11.008	0.750
415899N	410	N	3.500	4.375	4.381	0.562	416267	410	S	2.125	3.500	3.505	0.375
415937	410	S	3.625	4.750	4.758	0.500	416268	410	S	2.187	3.500	3.505	0.375
415938	410	S	5.375	6.624	6.632	0.562	416270	410	S	2.250	3.543	3.548	0.500
415953	410	S	4.000	4.999	5.007	0.500	416271	410	S	2.375	3.500	3.507	0.374
415958	410	S	3.875	5.376	5.381	0.500	416271A	410	A	2.375	3.500	3.507	0.374
415960	410	S	2.750	3.876	3.883	0.438	416273	410	S	2.500	3.623	3.630	0.374
415962	410	S	3.000	4.331	4.336	0.500	416278	410	S	2.625	4.249	4.254	0.468
415983	410	S	3.750	4.500	4.507	0.468	416282	410	S	2.750	4.249	4.254	0.468
415983N	410	N	3.750	4.500	4.507	0.468	416285	410	S	2.875	4.249	4.254	0.500
415983V	410	V	3.750	4.500	4.507	0.468	416288	410	S	3.125	4.249	4.256	0.500
415984	410	S	2.750	3.623	3.630	0.374	416292	410	S	3.312	4.248	4.255	0.437
415988	410	S	2.562	3.623	3.625	0.375	416294	410	S	3.375	4.249	4.256	0.500
415991	410	S	3.500	4.501	4.506	0.438	416294V	410	V	3.375	4.249	4.256	0.500
415991N	410	N	3.500	4.501	4.506	0.438	416297	410	S	3.125	4.626	4.633	0.438
415995	410	S	3.000	4.003	4.008	0.375	416313	410	S	3.312	4.751	4.756	0.500
415995A	410	A	3.000	4.003	4.008	0.375	416321	410	S	3.375	4.751	4.756	0.500
415995V	410	V	3.000	4.003	4.008	0.375	416327	410	S	3.375	5.251	5.256	0.468
416008	410	S	6.750	8.500	8.509	0.625	416332	410	S	3.625	4.625	4.631	0.437
416011	410	S	3.125	4.125	4.132	0.500	416339	410	S	3.750	4.999	5.007	0.500
416024	410	S	3.125	4.751	4.756	0.500	416345	410	S	3.875	4.999	5.007	0.500
416029	410	S	5.750	7.874	7.881	0.750	416362	410	S	6.750	8.007	8.017	0.625
416029N	410	N	5.750	7.874	7.881	0.750	416364	410	S	7.000	8.000	8.009	0.625
416039	410	S	5.750	7.500	7.508	0.562	416370	410	S	3.000	4.751	4.756	0.625
416041	410	S	3.750	4.626	4.633	0.500	416380	410	S	4.375	5.500	5.506	0.500
416043	410	S	3.875	5.751	5.756	0.562	416381	410	S	9.625	12.750	12.758	1.250
416044	410	S	7.250	8.250	8.257	0.625	416383	410	S	10.750	13.374	13.381	1.250
416047	410	S	3.625	4.626	4.633	0.500	416394	410	S	8.500	10.625	10.633	0.750
416070	410	S	4.500	6.125	6.131	0.562	416404	410	S	3.125	4.003	4.010	0.438
416071	410	S	2.375	3.751	3.756	0.500	416422	410	S	8.250	11.500	11.507	0.750
416077	410	S	7.125	8.625	8.632	0.562	416444	410	S	2.312	3.500	3.505	0.375
416102	410	S	7.625	8.625	8.632	0.562	416470N	410	N	3.250	4.249	4.254	0.375
416107	410	S	5.500	6.750	6.758	0.575	416476	410	S	5.875	7.125	7.133	0.500

Part Number	Style	Matl	Shaft	Bore	O.D.	Width	Part Number	Style	Matl	Shaft	Bore	O.D.	Width
416500	410	S	2.938	3.938	3.945	0.500	417262	410	S	5.250	6.250	6.256	0.500
416556	410	S	4.250	5.250	5.258	0.500	417262V	410	V	5.250	6.250	6.256	0.500
416557	410	S	5.125	6.125	6.131	0.500	417267	410	S	4.875	6.125	6.131	0.500
416624	410	S	3.500	4.376	4.383	0.500	417269	410	S	4.875	6.250	6.256	0.500
416624N	410	N	3.500	4.376	4.383	0.500	417273	410	S	4.937	6.250	6.256	0.500
416654	410	S	2.937	4.003	4.008	0.375	417278	410	S	5.000	6.375	6.381	0.500
416657	410	S	8.875	10.122	10.130	0.750	417283	410	S	7.500	9.243	9.250	0.625
416664	410	S	2.750	3.500	3.507	0.374	417295	410	S	4.437	5.500	5.506	0.500
416666	410	S	5.750	7.001	7.008	0.562	417298	410	S	6.625	8.125	8.134	0.625
416670	410	S	3.687	5.250	5.256	0.468	417316	410	S	2.750	3.751	3.758	0.374
416674V	410	V	7.000	8.375	8.382	0.750	417343	410	S	2.625	3.751	3.758	0.374
416706	410	S	2.750	4.003	4.008	0.375	417344	410	S	2.875	3.751	3.758	0.374
416738	410	S	2.062	3.190	3.194	0.437	417349	410	S	3.000	3.751	3.758	0.437
416775	410	S	2.937	4.250	4.254	0.468	417350	410	S	3.000	3.876	3.883	0.437
416865	410	S	5.000	6.251	6.250	0.500	417351	410	S	3.000	4.125	4.132	0.437
416888	410	S	4.500	5.500	5.508	0.500	417352	410	S	3.250	4.500	4.507	0.500
416891	410	S	4.250	5.500	5.508	0.500	417353	410	S	3.250	4.626	4.633	0.500
416892	410	S	4.500	5.750	5.758	0.500	417354	410	S	3.375	4.626	4.633	0.500
416919	410	S	3.687	4.501	4.506	0.500	417355	410	S	3.625	4.875	4.883	0.500
416919N	410	N	3.687	4.501	4.506	0.500	417356	410	S	4.000	5.125	5.133	0.500
416921	410	S	2.875	4.003	4.010	0.374	417357	410	S	4.000	5.250	5.258	0.500
416951	410	S	8.250	10.625	10.633	0.750	417358	410	S	5.250	6.375	6.381	0.500
416956	410	S	2.937	3.751	3.756	0.375	417359	410	S	5.250	6.625	6.632	0.562
417016	410	S	7.875	10.000	10.008	0.625	417360	410	S	5.500	6.625	6.632	0.562
417020	410	S	10.000	12.000	12.008	0.625	417361	410	S	5.500	6.875	6.882	0.562
417022	410	S	8.375	10.375	10.385	0.625	417362	410	S	5.750	6.750	6.757	0.575
417040	410	S	5.625	7.125	7.131	0.500	417363	410	S	5.750	6.875	6.882	0.562
417073	410	S	2.437	3.543	3.548	0.375	417364	410	S	5.750	7.125	7.132	0.562
417079	410	S	2.625	3.543	3.548	0.375	417365	410	S	6.000	7.125	7.132	0.562
417082	410	S	2.625	4.003	4.008	0.375	417366	410	S	3.875	5.250	5.258	0.500
417115	410	S	7.750	10.000	10.008	0.750	417433	410	S	3.250	4.003	4.008	0.375
417134	410	S	2.875	4.125	4.130	0.375	417474	410	S	1.937	3.543	3.548	0.375
417158	410	S	2.875	3.876	3.883	0.374	417480	410	S	2.375	3.876	3.881	0.375
417159	410	S	2.937	3.876	3.881	0.375	417481	410	S	2.562	3.750	3.756	0.375
417171	410	S	3.125	4.376	4.383	0.500	417484	410	S	2.750	3.543	3.548	0.375
417172	410	S	3.125	4.500	4.507	0.500	417484N	410	N	2.750	3.543	3.548	0.375
417181	410	S	3.250	4.376	4.383	0.500	417485	410	S	2.813	3.875	3.882	0.438
417191	410	S	3.375	4.500	4.507	0.500	417486	410	S	2.937	4.125	4.130	0.375
417196	410	S	3.500	4.626	4.633	0.500	417487	410	S	3.000	4.249	4.254	0.437
417198	410	S	3.500	4.875	4.881	0.500	417488	410	S	3.000	4.375	4.382	0.625
417205	410	S	3.750	4.875	4.883	0.500	417490	410	S	3.187	4.376	4.381	0.500
417210	410	S	3.875	4.751	4.756	0.375	417491	410	S	3.312	4.376	4.381	0.500
417211	410	S	3.875	4.875	4.883	0.500	417492	410	S	3.437	4.501	4.506	0.375
417223	410	S	4.000	6.250	6.256	0.500	417493	410	S	3.437	4.626	4.631	0.500
417238	410	S	4.312	6.250	6.256	0.500	417494	410	S	3.437	4.876	4.881	0.500
417247	410	S	4.750	6.001	6.009	0.500	417495	410	S	3.500	5.126	5.131	0.500
417252	410	S	4.750	6.125	6.131	0.500	417496	410	S	3.500	5.500	5.505	0.500
417254	410	S	5.500	6.500	6.507	0.562	417497	410	S	3.562	4.751	4.756	0.500
417255	410	S	7.000	8.375	8.382	0.625	417498	410	S	3.562	4.876	4.881	0.500
417258	410	S	5.125	6.250	6.256	0.500	417499	410	S	3.625	5.251	5.256	0.437

Part Number	Style	Matl	Shaft	Bore	O.D.	Width	Part Number	Style	Matl	Shaft	Bore	O.D.	Width
417500	410	S	3.625	5.501	5.506	0.500	417571	410	S	11.000	12.500	12.510	0.625
417501	410	S	3.687	4.750	4.756	0.500	417584	410	S	5.000	6.126	6.131	0.562
417502	410	S	3.687	5.501	5.506	0.500	417596	410	S	6.750	8.250	8.257	0.562
417503	410	S	3.750	5.501	5.506	0.500	417597	410	S	7.000	8.250	8.257	0.625
417504	410	S	3.812	4.876	4.881	0.500	417598	410	S	7.625	9.125	9.133	0.625
417505	410	S	3.875	5.501	5.506	0.500	417598V	410	V	7.625	9.125	9.133	0.625
417507	410	S	4.000	5.626	5.632	0.375	417600	410	S	8.000	9.250	9.258	0.625
417509	410	S	4.000	5.999	6.005	0.500	417601	410	S	8.000	9.500	9.508	0.625
417511	410	S	4.125	5.126	5.132	0.500	417602	410	S	8.000	10.000	10.008	0.625
417512	410	S	4.125	5.501	5.506	0.500	417603	410	S	8.500	10.000	10.008	0.625
417513	410	S	4.187	5.501	5.506	0.500	417604	410	S	8.500	10.500	10.508	0.625
417514	410	S	4.187	5.751	5.756	0.500	417605	410	S	10.000	11.000	11.008	0.625
417515	410	S	4.187	6.000	6.007	0.500	417606	410	S	9.500	11.500	11.508	0.625
417516	410	S	4.187	6.250	6.256	0.500	417608	410	S	12.000	14.000	14.010	0.750
417518	410	S	4.250	6.126	6.133	0.500	417621	410	S	3.125	4.125	4.130	0.375
417520	410	S	4.312	5.751	5.756	0.500	417698	410	S	3.625	4.376	4.381	0.375
417522	410	S	4.375	6.125	6.131	0.500	417780	410	S	5.937	7.502	7.508	0.562
417525	410	S	4.437	5.751	5.756	0.500	417817	410	S	7.937	8.750	8.757	0.565
417526	410	S	4.437	5.999	6.007	0.500	417939	410	S	9.910	10.995	11.005	0.625
417530	410	S	4.500	5.375	5.383	0.438	417940	410	S	9.000	10.088	10.095	0.625
417531	410	S	4.500	5.876	5.881	0.500	417967	410	S	3.937	4.876	4.881	0.500
417532	410	S	4.500	6.374	6.382	0.500	417986N	410	N	2.750	5.500	5.506	0.500
417533	410	S	4.562	5.751	5.756	0.500	417987N	410	N	3.250	5.500	5.506	0.500
417534	410	S	4.562	5.999	6.007	0.500	418027	410	S	2.625	4.437	4.441	0.437
417535	410	S	4.687	5.999	6.007	0.500	418028	410	S	3.250	4.500	4.506	0.375
417536	410	S	4.687	6.250	6.256	0.500	418029	410	S	3.437	4.249	4.254	0.375
417537	410	S	4.687	6.374	6.382	0.500	◆425507XX	320	S	1.654	2.165	2.173	0.276
417538	410	S	4.750	5.876	5.881	0.500				42	55	55.20	7
417539	410	S	4.937	5.999	6.007	0.500	◆425508XX	350	S	1.654	2.165	2.176	0.315
417540	410	S	4.937	6.374	6.382	0.500				42	55	55.28	8
417541	410	S	5.000	6.499	6.507	0.500	◆425607XX	320	S	1.654	2.205	2.21	0.276
417542	410	S	5.000	6.749	6.757	0.500				42	56	56.13	7
417543	410	S	5.000	6.874	6.882	0.500	◆425807XX	480	S	1.654	2.283	2.287	0.276
417544	410	S	5.000	7.000	7.007	0.500				42	58	58.10	7
417545	410	S	5.000	7.500	7.507	0.500	◆426007XX	320	S	1.654	2.362	2.371	0.276
417546	410	S	5.125	6.374	6.382	0.500				42	60	60.22	7
417547	410	S	5.125	6.499	6.507	0.500	◆426208XX	350	S	1.654	2.441	2.452	0.315
417548	410	S	5.187	6.499	6.507	0.500				42	62	62.27	8
417549	410	S	5.250	6.750	6.757	0.500	◆426510XX	470	N	1.654	2.559	2.565	0.394
417550	410	S	5.312	6.500	6.507	0.500				42	65	65.15	10
417551	410	S	5.375	6.374	6.380	0.500	◆426808XX	320	S	1.654	2.677	2.685	0.315
417554	410	S	5.375	6.749	6.757	0.500				42	68	68.20	8
◆417555	410	S	5.625	6.626	6.634	0.516	◆426810XX	320	S	1.654	2.677	2.685	0.394
			143	168.30	168.50	13.10				42	68	62.20	10
417556	410	S	5.625	6.874	6.882	0.500	◆427010XX	320	S	1.654	2.756	2.764	0.394
417562	410	S	6.250	7.750	7.758	0.500				42	70	70.20	10
417563	410	S	6.375	7.875	7.883	0.500	◆427208XX	320	S	1.654	2.835	2.843	0.315
417564	410	S	7.000	8.750	8.759	0.625				42	72	72.20	8
417567	410	S	8.625	10.625	10.635	0.750	◆427210XX	320	S	1.654	2.835	2.845	0.394
417570	410	S	10.250	12.250	12.260	0.750				42	72	72.27	10
							◆428008XX	320	S	1.654	3.15	3.157	0.315
										42	80	80.20	8
							◆428010XX	350	S	1.654	3.15	3.157	0.394
										42	80	80.20	10

Part Number	Style	Matl	Shaft	Bore	O.D.	Width	Part Number	Style	Matl	Shaft	Bore	O.D.	Width
◆435508XX	320	S	1.693 43	2.165 55	2.173 55.20	0.315 8	450065	450	S	1.593	2.437	2.441	0.468
◆436508XX	320	S	1.693 43	2.559 65	2.567 65.20	0.315 8	450066	450	S	1.625	2.438	2.444	0.375
440131	440	S	0.875	1.375	1.379	0.187	450067	450	S	1.500	2.502	2.508	0.500
440265	440	S	1.687	2.623	2.629	0.375	450068	450	S	1.718	2.623	2.627	0.500
440511	440	S	2.625	3.371	3.376	0.250	450069	450	S	1.625	2.623	2.629	0.313
440972	440	S	2.125	3.371	3.376	0.312	450070	450	S	1.750	2.623	2.629	0.313
441130	440	S	1.000	1.375	1.381	0.189	450073	450	S	1.656	2.686	2.690	0.500
441319	440	S	1.218	1.979	1.983	0.250	450076	450	S	1.750	2.686	2.692	0.438
441853	440	S	1.875	2.561	2.567	0.313	450078	450	S	1.625	2.875	2.881	0.313
442109	440	S	2.250	3.371	3.378	0.374	450082	450	S	1.875	2.875	2.881	0.311
442251	440	S	1.718	2.561	2.567	0.500	450083	450	S	2.000	2.875	2.881	0.469
442380	440	S	2.500	3.252	3.259	0.250	450084	450	S	1.875	2.996	3.001	0.500
442507	440	S	2.374	3.350	3.357	0.251	450085	450	S	2.000	2.995	3.002	0.500
442874	440	S	2.314	3.000	3.006	0.382	450087	450	S	1.750	3.061	3.067	0.500
443018	440	S	1.500	1.983	1.989	0.189	450089	450	S	1.781	3.189	3.194	0.437
444042	440	S	2.500	3.500	3.507	0.250	450090	450	S	1.812	3.189	3.194	0.437
444116	440	S	1.812	2.327	2.332	0.437	450094N	450	N	1.937	3.189	3.194	0.437
444258	440	S	0.375	0.836	0.841	0.187	450094	450	S	1.937	3.189	3.194	0.437
◆446007XX	320	S	1.732 44	2.362 60	2.37 60.20	0.276 7	450095	450	S	2.000	3.189	3.194	0.437
◆446010XX	350	S	1.732 44	2.362 60	2.37 60.20	0.394 10	450096	450	S	2.062	3.189	3.194	0.437
◆446208XX↔	320	S	1.732 44	2.441 62	2.451 62.26	0.315 8	450099	450	S	2.250	3.350	3.357	0.469
◆446510XX	350	S	1.732 44	2.559 65	2.57 65.28	0.394 10	450101	450	S	2.375	3.350	3.357	0.469
446927	440	S	3.500	4.125	4.130	0.250	450103	450	S	2.375	3.483	3.490	0.500
◆447008XX	320	S	1.732 44	2.756 70	2.764 70.20	0.315 8	450104	450	S	2.437	3.481	3.486	0.500
447060	440	S	5.250	6.250	6.256	0.250	450111	450	S	1.968	3.350	3.355	0.468
◆447210XX	350	S	1.732 44	2.835 72	2.839 72.11	0.394 10	450115	450	S	2.125	2.996	3.002	0.438
447793	440	S	6.000	6.751	6.757	0.375	450116	450	S	1.812	2.875	2.879	0.468
450005	450	S	0.500	1.124	1.130	0.250	450117	450	S	1.875	2.750	2.756	0.311
450009	450	S	0.625	1.124	1.130	0.250	450118	450	S	1.812	2.750	2.756	0.313
450025	450	S	0.687	1.374	1.380	0.311	450119	450	S	0.500	1.000	1.009	0.252
450027	450	S	0.750	1.375	1.381	0.252	450120	450	S	1.000	1.499	1.503	0.390
450030	450	S	0.813	1.499	1.505	0.250	450121	450	S	2.125	3.189	3.194	0.437
450032	450	S	0.875	1.500	1.506	0.313	450132	450	S	2.250	3.371	3.378	0.438
450034	450	N	0.781	1.828	1.834	0.250	450133	450	S	2.312	3.371	3.376	0.468
450038	450	S	0.906	1.828	1.832	0.437	450135	450	S	1.375	2.125	2.131	0.438
450039	450	S	0.938	1.828	1.834	0.438	450141	450	S	0.750	1.250	1.256	0.374
450040	450	S	0.987	1.282	1.288	0.438	450143	450	S	1.562	2.561	2.565	0.500
450043	450	S	1.063	1.828	1.834	0.250	450147	450	S	1.312	2.996	3.001	0.500
450044	450	S	1.093	1.828	1.832	0.437	450154	450	S	1.687	2.502	2.508	0.311
450045	450	S	1.125	1.828	1.834	0.311	450159	450	S	1.093	2.000	2.004	0.437
450048	450	S	1.218	1.983	1.987	0.437	450161	450	S	1.156	2.000	2.006	0.311
450049	450	S	1.250	1.983	1.989	0.252	450162	450	S	1.187	2.000	2.006	0.252
450054	450	S	1.343	2.374	2.378	0.500	450163	450	S	1.250	2.000	2.006	0.252
450059	450	S	1.500	2.374	2.380	0.313	450173	450	S	1.218	2.000	2.004	0.437
							450177	450	S	1.250	2.106	2.110	0.468
							450183	450	S	1.750	2.750	2.756	0.500
							450185	450	S	1.563	2.502	2.508	0.311
							450188	450	S	1.063	1.561	1.567	0.250
							450189	450	S	1.125	1.752	1.758	0.313
							450194	450	S	1.625	2.502	2.508	0.311

Part Number	Style	Matl	Shaft	Bore	O.D.	Width	Part Number	Style	Matl	Shaft	Bore	O.D.	Width
450204	450	S	0.813	1.375	1.381	0.252	450441	450	S	2.248	2.996	3.002	0.500
450219	450	S	1.000	1.624	1.630	0.375	450446	450	S	2.000	2.713	2.717	0.468
450236	450	S	1.125	1.874	1.880	0.250	450452	450	S	1.375	2.835	2.841	0.469
450241	450	S	1.125	2.063	2.069	0.313	450456	450	S	1.375	2.716	2.720	0.468
450244	450	S	1.250	2.062	2.066	0.437	450457	450	S	0.984	1.828	1.832	0.437
450260	450	S	1.656	2.502	2.506	0.500	450461	450	S	1.500	2.750	2.754	0.500
450269	450	S	1.781	2.686	2.690	0.500	450463	450	S	1.375	2.750	2.754	0.500
450273	450	S	1.562	2.758	2.762	0.500	450467	450	S	1.625	3.251	3.256	0.500
450274	450	S	1.593	2.758	2.762	0.500	450472	450	S	1.968	2.686	2.690	0.500
450275	450	S	1.625	2.758	2.762	0.500	◆450474	450	S	1.969	2.874	2.880	0.472
450279	450	S	1.937	2.758	2.762	0.500				50	73	73.15	12
450280	450	S	1.781	2.758	2.762	0.500	450482	450	S	1.156	1.828	1.832	0.437
450285	450	S	1.781	2.750	2.754	0.500	450489	450	S	2.187	2.875	2.881	0.374
450291	450	S	1.750	2.875	2.881	0.252	450492	450	S	1.375	3.350	3.357	0.469
450291N	450	N	1.750	2.875	2.881	0.252	450494	450	S	1.750	2.502	2.508	0.311
450298	450	S	1.875	3.000	3.006	0.313	450496	450	S	2.500	3.350	3.357	0.437
450301	450	S	2.000	3.000	3.006	0.500	450502	450	S	1.156	1.686	1.690	0.375
450303	450	S	2.125	3.000	3.006	0.500	450516	450	S	1.375	3.125	3.130	0.500
450307	450	S	2.062	3.061	3.066	0.500	450519	450	S	2.500	3.251	3.258	0.437
450308	450	S	2.125	3.061	3.067	0.500	450523	450	S	1.500	2.875	2.879	0.468
450311	450	S	2.062	3.125	3.130	0.500	450533	450	S	1.687	3.189	3.194	0.437
450312	450	S	2.125	3.125	3.131	0.374	450535	450	S	0.625	1.250	1.256	0.311
450313	450	S	2.062	3.251	3.256	0.500	450536	450	S	0.562	1.246	1.250	0.375
450316	450	S	2.250	3.251	3.258	0.500	450539	450	S	1.625	2.999	3.005	0.313
450317	450	S	2.313	3.251	3.258	0.500	450540	450	S	1.500	3.189	3.194	0.437
450326	450	S	1.500	2.996	3.001	0.500	450545	450	S	0.968	1.575	1.579	0.375
450329	450	S	2.625	3.350	3.356	0.468	450548	450	S	1.500	2.250	2.256	0.375
450332	450	S	1.125	2.437	2.441	0.468	450553	450	S	1.000	1.500	1.506	0.311
450335	450	S	1.625	3.062	3.066	0.500	450588	450	S	0.812	1.575	1.579	0.375
450339	450	S	0.968	2.062	2.066	0.437	450593	450	S	1.000	1.828	1.834	0.295
450340	450	S	0.750	1.561	1.565	0.375	450604	450	S	1.125	2.250	2.254	0.500
450341	450	S	1.250	2.713	2.717	0.468	450621	450	S	2.156	3.189	3.196	0.437
450342	450	S	1.062	1.983	1.987	0.437	450626	450	S	2.625	3.371	3.378	0.438
450343	450	S	2.062	3.371	3.376	0.468	450639	450	S	2.125	2.835	2.839	0.468
450350	450	S	2.375	3.371	3.378	0.469	450645	450	S	0.875	2.000	2.004	0.437
450351	450	S	1.750	2.437	2.443	0.313	450680	450	S	0.875	1.500	1.506	0.313
450352	450	S	1.750	2.502	2.513	0.500	450686	450	S	2.375	3.483	3.490	0.500
450358	450	S	1.625	2.374	2.380	0.311	450693	450	S	0.984	2.062	2.066	0.437
450361	450	S	1.750	2.561	2.567	0.500	450737	450	S	2.250	3.188	3.195	0.438
450362	450	S	1.156	2.125	2.129	0.437	450765	450	S	1.687	2.716	2.720	0.468
450365	450	S	2.125	2.875	2.881	0.375	450776	450	S	1.375	2.686	2.690	0.500
450365N	450	N	2.125	2.875	2.881	0.375	450803	450	S	1.562	2.716	2.720	0.468
450375	450	S	1.765	2.412	2.416	0.468	450819	450	S	1.625	2.835	2.839	0.468
450389	450	S	2.000	2.750	2.756	0.375	450867	450	S	2.125	2.875	2.881	0.375
450400	450	S	1.750	2.250	2.261	0.311	450869	450	S	2.156	3.251	3.256	0.500
450403	450	S	1.375	2.062	2.073	0.375	450911	450	S	1.968	2.742	2.746	0.500
450412	450	S	2.625	3.481	3.486	0.500	450911N	450	N	1.968	2.742	2.746	0.500
450415	450	S	1.625	2.996	3.001	0.500	450965	450	S	1.937	3.350	3.355	0.468
450430	450	S	1.125	2.875	2.879	0.468	450984	450	S	1.500	2.716	2.720	0.468
450431	450	S	0.813	1.250	1.256	0.189	451078	450	S	1.875	3.251	3.258	0.500

Part Number	Style	Matl	Shaft	Bore	O.D.	Width	Part Number	Style	Matl	Shaft	Bore	O.D.	Width
451082	450	S	0.968	1.874	1.878	0.437	455037	450	S	4.062	5.501	5.506	0.562
451147H	450	H	1.750	2.502	2.506	0.406	455056	450	S	4.125	6.250	6.256	0.562
451469	450	S	1.593	2.623	2.627	0.340	455060	450	S	4.375	6.250	6.256	0.562
451583	450	S	0.968	1.499	1.503	0.312	455068	450	S	4.874	6.250	6.258	0.500
451709	450	S	1.250	1.752	1.758	0.252	455070	450	S	5.000	6.250	6.258	0.500
451817	450	S	1.812	2.437	2.441	0.468	455073	450	S	5.500	6.749	6.757	0.625
451845	450	S	1.250	2.561	2.565	0.500	455075	450	S	5.875	7.125	7.135	0.625
451857	450	S	1.500	2.623	2.627	0.500	455079	450	S	2.500	3.750	3.757	0.500
452086	450	S	1.670	2.686	2.690	0.500	455080	450	S	2.125	3.623	3.628	0.468
452222	450	S	1.531	2.374	2.378	0.375	455086	450	S	3.000	4.249	4.256	0.468
452261H	450	H	2.000	2.500	2.504	0.437	455088	450	S	3.000	4.500	4.507	0.469
452554	450	S	1.500	1.983	1.989	0.252	455088V	450	V	3.000	4.500	4.507	0.469
452554N	450	N	1.500	1.983	1.989	0.252	455091	450	S	4.874	6.001	6.009	0.500
453059	450	S	0.437	1.124	1.128	0.406	455093	450	S	2.250	3.500	3.505	0.500
453063	450	S	1.187	2.047	2.051	0.437	455096	450	S	2.437	3.500	3.505	0.500
453065	450	S	1.500	2.250	2.256	0.313	455104	450	S	5.250	6.500	6.508	0.625
453066	450	S	2.125	2.878	2.882	0.375	455117	450	S	7.375	8.875	8.882	0.750
453165	450	S	1.000	2.062	2.066	0.375	455121V	450	V	7.875	9.375	9.383	0.750
453182	450	S	3.000	3.999	4.004	0.437	455123	450	S	8.125	10.125	10.130	0.750
453279	450	S	1.250	3.155	3.160	0.500	455129	450	S	8.875	10.875	10.885	0.750
453341	450	S	1.625	2.374	2.380	0.311	455134	450	S	4.125	4.998	5.006	0.437
454136N	450	N	2.250	3.350	3.355	0.312	455136	450	S	2.250	3.481	3.486	0.500
455001	450	S	2.500	3.542	3.549	0.500	455137	450	S	3.250	4.500	4.507	0.438
455001S	450	S	2.500	3.542	3.549	0.500	455144	450	S	2.875	4.499	4.504	0.468
455003	450	S	2.625	3.623	3.630	0.438	455146	450	S	3.500	4.499	4.504	0.468
455004	450	S	2.750	3.751	3.758	0.375	455147	450	S	2.500	3.500	3.507	0.500
455005	450	S	2.813	3.751	3.758	0.438	455151	450	S	2.687	3.751	3.756	0.500
455006	450	S	2.875	3.750	3.757	0.500	455154	450	S	3.000	4.125	4.132	0.438
455006N	450	N	2.875	3.750	3.757	0.500	455165	450	S	3.375	4.499	4.504	0.468
455009	450	S	2.750	3.876	3.883	0.437	455173	450	S	3.500	4.750	4.758	0.500
455011	450	S	2.874	4.003	4.010	0.437	455186	450	S	3.938	4.876	4.884	0.438
455012	450	S	2.937	4.003	4.010	0.438	455188	450	S	4.000	5.125	5.133	0.500
455013	450	S	3.000	4.003	4.010	0.437	455189	450	S	3.812	5.251	5.256	0.468
455014	450	S	3.000	4.249	4.256	0.468	455191	450	S	3.937	5.251	5.256	0.468
455015	450	S	3.062	4.249	4.254	0.625	455192	450	S	4.000	5.251	5.256	0.468
455018	450	S	3.250	4.249	4.256	0.500	455194	450	S	4.187	5.251	5.256	0.468
455018N	450	N	3.250	4.249	4.256	0.500	455195	450	S	4.250	5.251	5.256	0.468
455019	450	S	3.000	4.999	5.007	0.438	455197	450	S	4.312	5.501	5.506	0.562
455020	450	S	3.062	4.999	5.004	0.468	455197N	450	N	4.312	5.501	5.506	0.562
455022	450	S	3.187	4.999	5.004	0.468	455198	450	S	4.375	5.500	5.508	0.563
455024	450	S	3.312	4.999	5.004	0.468	455200	450	S	4.500	5.500	5.508	0.500
455026	450	S	3.437	4.999	5.004	0.468	455200N	450	N	4.500	5.500	5.508	0.500
455027	450	S	3.500	4.999	5.004	0.468	455203	450	S	4.125	6.000	6.007	0.625
455027N	450	N	3.500	4.999	5.004	0.468	455251H	450	H	4.812	5.751	5.756	0.562
455031	450	S	3.750	4.999	5.004	0.468	455253	450	S	2.000	3.543	3.548	0.500
455032	450	S	3.812	4.999	5.004	0.468	455260	450	S	2.062	3.623	3.628	0.468
455033	450	S	3.875	4.999	5.004	0.468	455272	450	S	2.750	4.003	4.010	0.438
455034	450	S	3.937	4.999	5.004	0.468	455280	450	S	2.562	3.876	3.881	0.468
455035	450	S	4.000	4.998	5.006	0.468	455290	450	S	5.062	6.374	6.382	0.625
455035N	450	N	4.000	4.998	5.006	0.468	455294	450	S	6.500	7.500	7.508	0.562

Part Number	Style	Matl	Shaft	Bore	O.D.	Width	Part Number	Style	Matl	Shaft	Bore	O.D.	Width
455297	450	S	5.875	7.500	7.508	0.562	455828V	450	V	8.500	9.500	9.509	0.625
455301	450	S	9.000	10.000	10.010	0.750	455858	450	S	3.438	4.756	4.764	0.563
455301S	450	S	9.000	10.000	10.010	0.750	455860	450	S	2.375	3.876	3.883	0.468
455308	450	S	1.500	3.543	3.550	0.375	455867V	450	V	7.500	8.500	8.509	0.625
455310	450	S	2.875	4.335	4.340	0.437	455948	450	S	6.875	7.875	7.883	0.625
455311	450	S	2.562	3.543	3.548	0.500	455956H	450	H	5.187	6.500	6.507	0.625
455321	450	S	2.312	3.751	3.756	0.500	455958	450	S	3.875	5.375	5.383	0.438
455322	450	S	2.750	3.543	3.550	0.438	455958S	450	S	3.875	5.375	5.383	0.438
455322N	450	N	2.750	3.543	3.550	0.438	455966	450	S	8.750	10.500	10.510	0.750
455322V	450	V	2.750	3.543	3.550	0.438	455995N	450	N	3.000	4.003	4.010	0.469
455328	450	S	3.250	5.251	5.256	0.468	◆456007XX	350	S	1.772	2.362	2.37	0.276
455330	450	S	6.125	7.125	7.135	0.626				45	60	60.20	7
455336	450	S	3.187	4.501	4.508	0.500	◆456008XX	350	S	1.772	2.362	2.37	0.315
455355	450	S	2.875	3.876	3.883	0.438				45	60	60.20	8
455356	450	S	2.937	4.499	4.504	0.468	◆456010XX	350	S	1.772	2.362	2.372	0.394
455364	450	S	2.750	3.500	3.507	0.374				45	60	60.25	10
455368	450	S	2.625	3.500	3.507	0.374	456052	450	S	5.875	7.999	8.007	0.750
455369	450	S	2.500	3.623	3.630	0.374	456055	450	V	6.000	7.001	7.008	0.625
455378H	450	H	4.687	5.751	5.756	0.562	456057	450	S	1.937	3.751	3.756	0.500
455379	450	S	3.750	4.750	4.758	0.500	456105	450	S	3.188	4.250	4.257	0.469
455379V	450	V	3.750	4.750	4.758	0.500	456141	450	S	4.312	5.376	5.381	0.500
455396	450	S	3.500	5.751	5.756	0.562	456153	450	S	4.500	5.625	5.631	0.500
455406	450	S	7.750	9.250	9.260	0.625	456192	450	S	5.500	7.500	7.507	0.562
455434	450	S	2.687	3.500	3.507	0.374	◆456208XX	350	S	1.772	2.441	2.453	0.315
455437N	450	N	3.500	4.751	4.756	0.500				45	62	62.30	8
455448	450	S	5.250	6.250	6.256	0.562	456305	450	S	3.250	4.751	4.756	0.484
455462	450	S	9.000	10.500	10.510	0.625	456462	450	S	9.000	10.375	10.384	0.625
455471	450	S	3.437	5.250	5.256	0.468	456464	450	S	9.910	10.997	11.005	0.625
455475	450	S	8.250	9.250	9.258	0.625	456472N	450	N	2.375	3.623	3.628	0.500
455476	450	S	9.000	10.250	10.260	0.750	◆456508XX	350	S	1.772	2.559	2.57	0.315
455479	450	S	3.000	3.876	3.883	0.437				45	65	65.28	8
455479V	450	V	3.000	3.876	3.883	0.437	456557	450	V	5.125	6.125	6.131	0.500
455480	450	S	6.250	7.500	7.508	0.562	456585	450	S	3.375	4.501	4.506	0.468
455480V	450	V	6.250	7.500	7.508	0.562	456641	450	H	4.625	5.500	5.506	0.562
455499	450	S	3.438	4.249	4.256	0.375	456648	450	S	3.313	4.500	4.507	0.438
455500	450	S	3.298	4.125	4.130	0.562	456744N	450	N	3.625	4.375	4.382	0.374
455509	450	S	3.000	3.936	3.941	0.500	◆456807XX	320	S	1.772	2.677	2.688	0.276
455513	450	S	4.000	5.625	5.633	0.437				45	68	68.28	7
455536	450	S	1.750	3.543	3.548	0.500	456837V	450	V	2.843	4.003	4.008	0.500
455547	450	S	3.875	5.125	5.133	0.500	456865N	450	N	5.000	6.250	6.256	0.500
455556	450	S	2.875	4.376	4.381	0.625	456890	450	S	4.812	6.250	6.256	0.500
455566	450	S	3.250	4.125	4.130	0.562	456967V	450	V	4.000	5.000	5.005	0.312
455576	450	S	5.375	6.499	6.507	0.562	◆457010XX	320	S	1.772	2.756	2.763	0.394
455583N	450	N	6.187	7.500	7.507	0.562				45	70	70.18	10
455584	450	S	6.875	8.375	8.382	0.625	457034	450	V	3.125	4.003	4.008	0.500
455655	450	S	2.500	4.003	4.008	0.468	457096V	450	V	10.000	11.500	11.508	0.750
455685	450	S	4.625	5.875	5.881	0.625	◆457207XX	350	S	1.772	2.835	2.846	0.276
◆455807XX	350	S	1.772	2.283	2.294	0.276				45	72	72.28	7
			45	58	58.28	7	◆457210XX	350	S	1.772	2.835	2.843	0.394
455820	450	S	3.000	4.875	4.881	0.625				45	72	72.20	10
							◆457212XX	350	S	1.772	2.835	2.846	0.472
										45	72	72.28	12
							457291	450	S	2.750	3.538	3.543	0.437

Part Number	Style	Matl	Shaft	Bore	O.D.	Width	Part Number	Style	Matl	Shaft	Bore	O.D.	Width
457294	450	S	4.000	4.750	4.756	0.562	470138V→	470	V	1.937	2.686	2.690	0.500
◆457295XX	320	S	1.772	2.835	2.844	0.394	470140N	470	N	1.250	1.751	1.757	0.251
			45	72	72.25	10	470141	470	S	0.750	1.250	1.256	0.252
457295	250	S	4.437	5.501	5.509	0.563	470162	470	S	1.187	2.000	2.006	0.252
457299	450	S	7.750	9.000	9.010	0.625	470163	470	S	1.250	2.000	2.006	0.437
◆457507XX	320	S	1.772	2.953	2.961	0.276							
			45	75	75.20	7	470165	470	S	1.250	2.250	2.254	0.500
457585	450	S	4.562	6.250	6.256	0.500	470169	470	S	1.375	2.250	2.256	0.500
457734	450	S	4.720	6.312	6.318	0.473	470189	470	S	1.125	1.752	1.758	0.313
457874	450	S	6.125	7.627	7.633	0.625	470189H	470	H	1.125	1.752	1.758	0.313
457997	450	S	10.500	12.000	12.008	0.625	470190	470	S	1.500	2.561	2.565	0.500
458009V	450	V	8.250	9.500	9.509	0.625							
◆458010XX	350	S	1.772	3.15	3.161	0.394	470195	470	S	0.312	0.999	1.003	0.375
			45	80	80.28	10	470199	470	S	0.437	0.999	1.003	0.375
◆458510XX	350	S	1.772	3.346	3.354	0.394	470204	470	S	0.812	1.375	1.379	0.406
			45	85	85.20	10	470207	470	S	0.906	1.499	1.503	0.390
◆458513XX	450	S	1.772	3.346	3.356	0.512	470211	470	S	0.750	1.624	1.630	0.252
			45	85	85.25	13							
◆466507XX	320	S	1.811	2.559	2.567	0.276	470215	470	S	0.875	1.624	1.630	0.252
			46	65	65.20	7	470219	470	S	1.000	1.624	1.630	0.311
◆467008XX	320	S	1.811	2.756	2.764	0.315	470230	470	S	1.000	1.752	1.758	0.252
			46	70	70.20	8	470236	470	S	1.125	1.874	1.880	0.311
							470241	470	S	1.125	2.062	2.066	0.437
470004	470	S	0.468	1.124	1.126	0.375	470244	470	S	1.250	2.062	2.066	0.437
470005	470	S	0.500	1.124	1.130	0.252	470245	470	S	1.250	2.125	2.131	0.250
470009	470	S	0.625	1.124	1.130	0.252	470286	470	S	1.625	2.750	2.754	0.500
470014	470	S	0.500	1.250	1.256	0.250	470308N	470	N	2.125	3.061	3.067	0.500
470018	470	S	0.625	1.250	1.256	0.252	470328	470	S	1.187	1.686	1.690	0.375
470023	470	S	0.625	1.375	1.381	0.252	470331N	470	N	1.843	2.750	2.756	0.500
470025	470	S	0.687	1.375	1.379	0.406	470334	470	S	1.750	2.686	2.690	0.375
470027	470	S	0.750	1.375	1.381	0.252	470336	470	S	1.187	2.250	2.254	0.500
470032	470	S	0.875	1.500	1.506	0.311	470340	470	S	0.750	1.561	1.565	0.375
470034	470	S	0.781	1.828	1.832	0.437	470342	470	S	1.062	1.983	1.987	0.437
470039	470	S	0.937	1.828	1.832	0.437	470347	470	S	1.187	2.437	2.441	0.468
470041	470	S	1.000	1.828	1.832	0.437	470351	470	S	1.750	2.437	2.443	0.313
470045	470	S	1.125	1.828	1.832	0.437	470354	470	S	2.187	3.189	3.194	0.437
470049	470	S	1.250	1.983	1.989	0.252	470358	470	S	1.625	2.374	2.380	0.311
470050	470	S	1.281	1.983	1.987	0.437	470358N	470	N	1.625	2.374	2.380	0.311
470055N	470	N	1.375	2.374	2.378	0.500	470361	470	S	1.750	2.561	2.567	0.500
470059	470	S	1.500	2.374	2.380	0.313	470362	470	S	1.156	2.125	2.129	0.437
470062	470	S	1.437	2.374	2.380	0.311	470380	470	S	1.500	2.374	2.380	0.311
470064	470	S	1.563	2.438	2.444	0.375	470380A	470	A	1.500	2.374	2.380	0.311
470066	470	S	1.625	2.438	2.444	0.375	470380V	470	V	1.500	2.374	2.380	0.311
470074	470	S	1.687	2.686	2.690	0.500	470390	470	S	0.750	1.874	1.880	0.252
470077	470	S	1.500	2.758	2.762	0.500	470394	470	S	1.500	2.125	2.131	0.311
470086	470	S	1.687	3.062	3.066	0.500	470398	470	S	0.875	1.375	1.381	0.252
470088	470	S	1.750	3.189	3.194	0.437	470403	470	S	1.375	2.062	2.068	0.438
470094	470	S	1.937	3.189	3.194	0.437	470409	470	S	1.937	2.412	2.416	0.468
470109N	470	N	1.562	2.750	2.754	0.500	470451	470	S	1.500	2.062	2.068	0.438
470119	470	S	0.500	0.999	1.005	0.252	470460	470	S	1.687	2.561	2.565	0.500
470120	470	S	1.000	1.500	1.506	0.311	470487	470	S	1.500	2.686	2.690	0.500
470129	470	S	1.312	2.062	2.066	0.437	470487N	470	N	1.500	2.686	2.690	0.500
470135	470	S	1.375	2.125	2.131	0.311	470503	470	S	1.312	2.437	2.441	0.468

Part Number	Style	Matl	Shaft	Bore	O.D.	Width	Part Number	Style	Matl	Shaft	Bore	O.D.	Width
470506	470	S	0.718	1.250	1.254	0.375	470989	470	S	1.375	3.000	3.006	0.500
470515	470	S	0.812	1.561	1.565	0.375	471015	470	S	0.937	1.375	1.381	0.252
470530	470	S	2.000	2.996	3.001	0.375	471024	470	S	0.625	1.624	1.628	0.437
470541	470	S	1.000	1.752	1.758	0.252	471076	470	S	1.031	1.575	1.584	0.311
470543	470	S	2.000	2.716	2.720	0.468	471076V	470	V	1.031	1.575	1.584	0.311
470547	470	S	2.881	3.429	3.436	0.291	471100	470	S	1.125	1.624	1.630	0.252
470548	470	S	1.500	2.250	2.256	0.311	471103	470	S	0.375	0.999	1.004	0.250
470553	470	S	1.000	1.500	1.506	0.311	471105	470	S	1.375	2.875	2.879	0.468
470557	470	S	0.625	1.375	1.381	0.252	471137	470	S	0.875	1.828	1.833	0.252
470565	470	S	2.375	3.125	3.131	0.374	471138	470	S	2.250	3.125	3.131	0.374
470567	470	S	0.875	1.375	1.381	0.252	471141	470	S	1.750	2.875	2.879	0.375
470567N	470	N	0.875	1.375	1.381	0.252	471169	470	S	1.750	2.411	2.415	0.380
470574N	470	N	2.375	3.251	3.256	0.500	471192	470	S	1.375	2.125	2.131	0.311
470588	470	S	0.812	1.575	1.579	0.375	471193	470	S	1.301	2.000	2.004	0.437
470590	470	S	0.875	1.752	1.758	0.252	471195	470	S	1.937	2.502	2.506	0.375
470592	470	S	0.813	1.499	1.505	0.250	471224	470	S	1.000	1.499	1.505	0.252
470593	470	S	1.000	1.828	1.832	0.296	471224A	470	A	1.000	1.499	1.505	0.252
470596	470	S	1.687	2.835	2.841	0.469	471224V	470	V	1.000	1.499	1.505	0.252
470596V	470	V	1.687	2.835	2.841	0.469	471231	470	S	0.813	1.375	1.381	0.252
470601	470	S	0.781	1.250	1.254	0.250	471255	470	S	0.625	1.375	1.379	0.252
470604	470	S	1.125	2.250	2.254	0.500	471255A	470	A	0.625	1.375	1.379	0.252
470605	470	S	2.500	3.371	3.378	0.374	471255V	470	V	0.625	1.375	1.379	0.252
470606	470	S	1.063	1.686	1.691	0.313	471264	470	S	0.625	1.250	1.259	0.252
470625	470	S	1.500	2.250	2.256	0.311	◆152807XX	320	S	0.625	1.250	1.259	0.252
470625A	470	A	1.500	2.250	2.256	0.311				15	0.000	1.102	0.276
470625V	470	V	1.500	2.250	2.256	0.311	471267	470	S	0.875	1.375	1.381	0.252
470645	470	S	0.875	2.000	2.004	0.437	471267T	470	T	0.875	1.375	1.381	0.252
470672	470	S	1.399	2.250	2.254	0.250	471267A	470	A	0.875	1.375	1.381	0.252
470680	470	S	0.875	1.500	1.506	0.311	471267V	470	V	0.875	1.375	1.381	0.252
470682	470	S	1.563	2.623	2.629	0.313	471268	470	S	1.375	2.000	2.006	0.311
470687	470	S	1.687	3.125	3.130	0.500	471268N	470	N	1.375	2.000	2.006	0.311
470712	470	S	1.125	1.874	1.880	0.250	471270	470	S	1.000	1.561	1.565	0.250
470712A	470	A	1.125	1.874	1.880	0.250	471271	470	S	2.500	3.251	3.258	0.374
470712V	470	V	1.125	1.874	1.880	0.250	471271A	470	A	2.500	3.251	3.258	0.374
470737	470	S	2.250	3.188	3.195	0.438	471271V	470	V	2.500	3.251	3.258	0.374
470737N	470	N	2.250	3.188	3.195	0.438	471272	470	S	2.250	3.000	3.006	0.374
470764	470	S	2.375	2.996	3.001	0.500	471272N	470	N	2.250	3.000	3.006	0.374
470774	470	S	1.375	2.062	2.073	0.375	471276	470	S	1.375	2.441	2.447	0.375
470774V	470	V	1.375	2.062	2.073	0.375	471276V	470	V	1.375	2.441	2.447	0.375
470806	470	S	1.250	2.835	2.841	0.374	471281	470	S	0.563	1.125	1.131	0.252
470808	470	S	1.437	2.750	2.754	0.500	471291V	470	V	0.625	1.181	1.185	0.350
470895	470	S	0.750	1.375	1.381	0.252	471316	470	S	1.563	2.686	2.692	0.313
470898	470	S	2.125	2.875	2.881	0.374	471337	470	S	0.781	1.752	1.757	0.311
470898A	470	A	2.125	2.875	2.881	0.374	471341	470	S	2.250	2.996	3.001	0.437
470946	470	S	1.187	2.686	2.690	0.500	471341N	470	N	2.250	2.996	3.001	0.437
470950	470	S	1.375	2.437	2.441	0.375	471344	470	S	1.500	2.441	2.447	0.313
470954	470	S	0.750	1.250	1.256	0.252	471354	470	S	1.187	2.062	2.068	0.250
470954A	470	A	0.750	1.250	1.256	0.252	471379	470	S	1.375	3.149	3.155	0.374
470954V	470	V	0.750	1.250	1.256	0.252	471391	470	S	1.937	3.125	3.130	0.375
470987	470	S	2.375	3.481	3.486	0.437	471405	470	S	1.437	3.000	3.005	0.500

Part Number	Style	Matl	Shaft	Bore	O.D.	Width	Part Number	Style	Matl	Shaft	Bore	O.D.	Width
471407	470	S	1.250	2.441	2.445	0.375	471645	470	S	0.812	1.624	1.628	0.250
471413	470	S	1.250	1.752	1.758	0.250	471645V	470	V	0.812	1.624	1.628	0.250
471413A	470	A	1.250	1.752	1.758	0.250	471646	470	S	0.875	1.624	1.630	0.252
471413V	470	V	1.250	1.752	1.758	0.250	471647	470	S	0.937	1.624	1.628	0.250
471419	470	S	1.625	2.438	2.444	0.375	471648	470	S	0.968	1.624	1.628	0.250
471424	470	S	2.000	2.623	2.629	0.311	471649	470	S	1.000	1.624	1.630	0.250
471424A	470	A	2.000	2.623	2.629	0.311	471649A	470	A	1.000	1.624	1.630	0.250
471424V	470	V	2.000	2.623	2.629	0.311	471649V	470	V	1.000	1.624	1.630	0.250
471442	470	S	0.500	0.999	1.005	0.252	471651	470	S	1.062	1.624	1.633	0.251
471442A	470	A	0.500	0.999	1.005	0.252	471652	470	S	1.125	1.624	1.630	0.252
471442V	470	V	0.500	0.999	1.005	0.252	471652A	470	A	1.125	1.624	1.630	0.252
471443	470	S	0.781	1.375	1.381	0.252	471652V	470	V	1.125	1.624	1.630	0.252
471465	470	S	1.000	1.689	1.695	0.252	471653	470	S	0.625	1.624	1.628	0.312
471466	470	S	0.625	1.124	1.128	0.252	471653A	470	S	0.750	1.752	1.756	0.250
471466A	470	A	0.625	1.124	1.128	0.252	471684	470	S	0.812	1.752	1.756	0.250
471466V	470	V	0.625	1.124	1.128	0.252	471686	470	S	0.812	1.752	1.756	0.250
471466V	470	V	0.625	1.124	1.128	0.252	471688	470	S	0.968	1.752	1.756	0.250
471472	470	S	0.500	1.250	1.256	0.250	471689	470	S	1.000	1.752	1.758	0.252
471472V	470	V	0.500	1.250	1.256	0.250	471689A	470	A	1.000	1.752	1.758	0.252
471498	470	S	0.750	1.575	1.584	0.311	471689V	470	V	1.000	1.752	1.758	0.252
471504	470	S	1.750	2.437	2.443	0.313	471692	470	S	1.125	1.752	1.758	0.250
471516	470	S	1.000	2.441	2.445	0.375	471692A	470	A	1.125	1.752	1.758	0.250
471526	470	S	0.500	1.124	1.128	0.252	471698	470	S	0.750	1.752	1.756	0.312
471526A	470	A	0.500	1.124	1.128	0.252	471705	470	S	1.062	1.752	1.756	0.312
471529	470	S	0.687	1.124	1.130	0.252	471707	470	S	1.156	1.752	1.756	0.312
471530	470	S	0.531	1.124	1.128	0.312	471707N	470	N	1.156	1.752	1.756	0.312
471532	470	S	0.593	1.124	1.128	0.312	471709	470	S	1.250	1.752	1.758	0.313
471535	470	S	0.562	1.250	1.254	0.250	471729	470	S	0.812	1.874	1.878	0.250
471538	470	S	0.687	1.250	1.256	0.250	471730	470	S	0.875	1.875	1.881	0.252
471539	470	S	0.813	1.250	1.256	0.232	471733	470	S	1.000	1.874	1.880	0.252
471540V	470	V	0.781	1.250	1.254	0.375	471735	470	S	1.062	1.874	1.878	0.250
471549	470	S	0.500	1.375	1.379	0.250	471736	470	S	1.156	1.874	1.878	0.250
471551	470	S	0.563	1.378	1.384	0.252	471737	470	S	1.250	1.874	1.880	0.252
471553	470	S	0.687	1.375	1.379	0.250	471744	470	S	1.000	1.983	1.987	0.250
471554	470	S	0.750	1.375	1.381	0.252	471747	470	S	1.125	1.983	1.989	0.250
471554A	470	A	0.750	1.375	1.381	0.252	471750	470	S	1.250	1.983	1.989	0.252
471554V	470	V	0.750	1.375	1.381	0.252	471750A	470	A	1.250	1.983	1.989	0.252
471555	470	S	0.500	1.375	1.379	0.312	471750V	470	V	1.250	1.983	1.989	0.252
471558	470	S	0.593	1.375	1.379	0.312	471760	470	S	1.000	2.000	2.006	0.252
471564	470	S	0.625	1.499	1.505	0.252	471760A	470	A	1.000	2.000	2.006	0.252
471567	470	S	0.750	1.499	1.505	0.252	471760V	470	V	1.000	2.000	2.006	0.252
471570	470	S	0.875	1.499	1.503	0.250	471762	470	S	1.063	2.000	2.006	0.250
471570V	470	V	0.875	1.499	1.503	0.250	471763	470	S	1.125	2.000	2.006	0.252
471571	470	S	0.937	1.499	1.503	0.250	471763A	470	A	1.125	2.000	2.006	0.252
471571V	470	V	0.937	1.499	1.503	0.250	471763V	470	V	1.125	2.000	2.006	0.252
471579	470	S	0.687	1.499	1.503	0.312	471765	470	S	1.187	2.000	2.006	0.252
471612	470	S	0.625	1.574	1.580	0.311	471766	470	S	1.250	2.000	2.006	0.252
471619	470	S	1.000	2.062	2.066	0.250	471766A	470	A	1.250	2.000	2.006	0.252
471633	470	S	0.875	1.577	1.581	0.250	471766V	470	V	1.250	2.000	2.006	0.252
471642	470	S	0.687	1.624	1.628	0.250	471772	470	S	1.062	2.000	2.004	0.375
471643	470	S	0.750	1.624	1.630	0.252	471785	470	S	1.125	2.062	2.066	0.250

Part Number	Style	Matl	Shaft	Bore	O.D.	Width	Part Number	Style	Matl	Shaft	Bore	O.D.	Width
471787	470	S	1.250	2.062	2.066	0.250	472164V	470	V	1.750	2.502	2.508	0.311
471787A	470	A	1.250	2.062	2.066	0.250	472179	470	S	1.750	2.750	2.756	0.311
471795	470	S	1.250	2.125	2.131	0.250	472179A	470	A	1.750	2.750	2.756	0.311
471795N	470	N	1.250	2.125	2.131	0.250	472185	470	S	1.750	2.623	2.629	0.311
471801	470	S	1.250	2.252	2.256	0.375	472189A←	470	S	1.500	2.377	2.629	0.311
471808	470	S	1.250	2.374	2.380	0.311	472193	470	S	1.750	2.561	2.566	0.312
471817	470	S	1.812	2.437	2.441	0.468	472213	470	S	1.563	2.250	2.256	0.311
471818	470	S	1.250	2.437	2.443	0.311	472222	470	S	1.531	2.374	2.379	0.375
471820	470	S	1.500	2.437	2.441	0.375	472234	470	S	2.187	2.996	3.001	0.375
471821	470	S	1.563	2.438	2.444	0.375	472238	470	S	0.968	2.440	2.445	0.375
471827	470	S	1.562	2.441	2.445	0.375	472239	470	S	1.156	2.834	2.839	0.375
471829	470	S	1.625	2.438	2.444	0.375	472258	470	S	1.375	2.000	2.006	0.311
471829V	470	V	1.625	2.438	2.444	0.375	472258A	470	A	1.375	2.000	2.006	0.311
471831	470	S	1.750	2.441	2.447	0.374	472258V	470	V	1.375	2.000	2.006	0.311
471833	470	S	1.250	2.502	2.506	0.375	472287	470	S	1.375	2.106	2.110	0.312
471835	470	S	1.375	2.500	2.506	0.313	472299V	470	V	1.563	2.374	2.380	0.311
471841	470	S	1.843	2.502	2.506	0.375	472299	470	S	1.563	2.374	2.380	0.311
471845N	470	N	1.250	2.561	2.565	0.500	472311	470	S	1.000	1.437	1.441	0.250
471847N	470	N	1.375	2.561	2.567	0.374	472311V	470	V	1.000	1.437	1.441	0.250
471854	470	S	1.937	2.561	2.565	0.500	472319	470	S	1.937	2.623	2.629	0.313
471866	470	S	1.812	2.686	2.690	0.375	472324	470	S	0.980	1.500	1.506	0.252
471868	470	S	1.875	2.686	2.692	0.313	472324A	470	A	0.980	1.500	1.506	0.252
471869	470	S	1.937	2.686	2.692	0.311	472324V	470	V	0.980	1.500	1.506	0.252
471870	470	S	2.000	2.686	2.692	0.374	472341	470	S	2.000	2.742	2.748	0.375
471883	470	S	2.000	2.686	2.690	0.437	472350	470	S	1.187	2.165	2.169	0.250
471887	470	S	2.437	3.125	3.130	0.375	472354	470	S	1.375	1.874	1.880	0.313
471904	470	S	1.313	2.835	2.841	0.375	472394	470	S	1.937	3.000	3.006	0.311
471915	470	S	1.500	2.835	2.839	0.468	472397	470	S	2.000	3.000	3.006	0.311
471923N	470	N	1.625	2.875	2.879	0.437	472419	470	S	1.625	2.116	2.120	0.312
471950	470	S	2.125	2.758	2.762	0.437	472432	470	S	1.188	2.440	2.446	0.251
471952	470	S	2.187	2.835	2.839	0.468	472439	470	S	1.875	2.623	2.629	0.313
471958	470	S	1.500	3.000	3.006	0.374	472439A	470	A	1.875	2.623	2.629	0.313
471981	470	S	1.687	3.000	3.006	0.375	472439V	470	V	1.875	2.623	2.629	0.313
471984	470	S	1.750	3.000	3.006	0.374	472446	470	S	1.500	3.149	3.155	0.438
472012	470	S	2.062	3.000	3.006	0.311	472452	470	S	0.843	1.374	1.378	0.312
472015	470	S	2.125	3.000	3.005	0.375	472466	470	S	1.500	2.048	2.052	0.375
472015V	470	V	2.125	3.000	3.005	0.375	472467	470	S	0.500	1.378	1.382	0.406
472016	470	S	2.125	3.125	3.131	0.374	472475	470	S	1.187	1.874	1.880	0.252
472018	470	S	2.187	3.000	3.006	0.374	472492	470	S	2.000	2.750	2.756	0.311
472020	470	S	2.187	3.125	3.131	0.375	472492A	470	A	2.000	2.750	2.756	0.311
472029	470	S	2.500	3.189	3.194	0.375	472535	470	S	1.125	2.533	2.537	0.250
472041	470	S	1.875	2.502	2.506	0.375	472536	470	S	1.250	2.877	2.881	0.250
472070	470	S	1.812	2.623	2.627	0.375	472538	470	S	0.750	2.127	2.131	0.250
472082	470	S	2.000	2.884	2.890	0.311	472539	470	S	1.000	2.533	2.537	0.250
472138	470	S	1.000	2.047	2.051	0.312	472554	470	S	1.500	1.983	1.989	0.252
472144	470	S	1.937	2.875	2.881	0.313	472560N	470	N	1.125	1.561	1.567	0.250
472150	470	S	2.313	3.125	3.131	0.375	472572	470	S	1.875	2.750	2.756	0.311
472157	470	S	4.250	5.251	5.256	0.375	472591	470	S	1.500	2.328	2.332	0.437
472164	470	S	1.750	2.502	2.508	0.311	472635	470	S	1.552	2.502	2.506	0.500
472164A	470	A	1.750	2.502	2.508	0.311	472636	470	S	2.250	3.251	3.258	0.374

Part Number	Style	Matl	Shaft	Bore	O.D.	Width	Part Number	Style	Matl	Shaft	Bore	O.D.	Width
472642	470	S	1.375	2.047	2.053	0.311	473215	470	S	1.375	2.374	2.380	0.311
472642V	470	V	1.375	2.047	2.053	0.311	473224	470	S	1.437	2.125	2.131	0.313
472644	470	S	1.125	2.047	2.053	0.311	473225	470	S	1.437	2.374	2.380	0.311
472644V	470	V	1.125	2.047	2.053	0.311	473226	470	S	1.437	2.502	2.508	0.311
472649	470	S	0.750	2.047	2.053	0.311	473227	470	S	1.500	2.125	2.131	0.311
472651V	470	V	1.250	3.150	3.155	0.375	473227V	470	V	1.500	2.125	2.131	0.311
472653	470	S	2.000	2.835	2.839	0.375	473228	470	S	1.500	2.502	2.508	0.311
472653V	470	V	2.000	2.835	2.839	0.375	473229	470	S	1.563	2.502	2.508	0.311
472655	470	S	1.437	2.312	2.318	0.374	473230	470	S	1.625	2.250	2.256	0.311
472658	470	S	1.375	2.835	2.841	0.374	473231	470	S	1.625	2.374	2.380	0.311
472660	470	S	1.656	2.938	2.944	0.374	473231A	470	A	1.625	2.374	2.380	0.311
472674	470	S	1.125	1.983	1.987	0.375	473232	470	S	1.625	2.623	2.629	0.311
472681	470	S	1.125	2.441	2.445	0.375	473233	470	S	1.687	2.374	2.380	0.311
472681V	470	V	1.125	2.441	2.445	0.375	473234	470	S	1.687	2.502	2.508	0.311
472705	470	S	0.562	0.999	1.005	0.250	473235	470	S	1.687	2.623	2.629	0.311
472747	470	S	1.875	2.470	2.475	0.437	473236	470	S	1.687	2.750	2.756	0.311
472758V	470	V	1.625	2.502	2.506	0.250	473237	470	S	1.750	2.374	2.380	0.311
472810	470	S	0.437	0.875	0.881	0.252	473237V	470	V	1.750	2.374	2.380	0.311
472826	470	S	1.312	2.062	2.066	0.312	473238	470	S	1.875	2.875	2.881	0.311
472843	470	S	1.375	2.623	2.627	0.375	473239	470	S	1.875	3.000	3.006	0.313
472856	470	S	2.375	3.350	3.355	0.438	473240	470	S	1.872	3.125	3.131	0.313
472878	470	S	0.735	1.248	1.252	0.250	473241	470	S	1.937	2.750	2.756	0.313
472924	470	S	2.000	2.875	2.881	0.311	473242	470	S	2.000	3.125	3.131	0.311
472950	470	S	0.813	2.441	2.447	0.313	473243	470	S	2.125	3.251	3.258	0.374
472951	470	S	0.937	1.750	1.756	0.311	473244	470	S	2.187	2.875	2.881	0.374
472953V	470	V	1.063	2.835	2.841	0.374	473245	470	S	2.187	3.251	3.258	0.374
472953	470	S	1.063	2.835	2.841	0.374	473258	470	S	1.375	2.561	2.567	0.374
472954	470	S	1.125	2.835	2.841	0.374	473259	470	S	1.125	2.441	2.445	0.250
472954V	470	V	1.125	2.835	2.841	0.374	473274	470	S	2.500	3.428	3.435	0.375
473010	470	S	1.625	2.502	2.508	0.311	473274N	470	N	2.500	3.428	3.435	0.375
473010A	470	A	1.625	2.502	2.508	0.311	473313	470	S	1.750	3.061	3.066	0.375
473010N	470	N	1.625	2.502	2.508	0.311	473317	470	S	1.688	2.328	2.334	0.313
473016	470	S	1.437	2.250	2.256	0.311	473336	470	S	1.719	2.561	2.567	0.500
473096	470	S	0.375	0.875	0.880	0.250	473367	470	S	1.625	2.437	2.441	0.312
473117	470	S	1.625	2.328	2.332	0.437	473380	470	S	1.000	1.575	1.579	0.250
473135V	470	V	1.250	1.686	1.691	0.250	473405	470	S	0.593	1.250	1.254	0.312
473157	470	S	1.750	2.449	2.453	0.312	473406	470	S	0.750	1.828	1.832	0.375
473179	470	S	1.875	2.758	2.764	0.313	473407	470	S	0.750	1.983	1.987	0.250
473197	470	S	1.375	2.835	2.841	0.311	473412	470	S	0.812	1.828	1.832	0.375
473197V	470	V	1.375	2.835	2.841	0.311	473413	470	S	0.843	1.499	1.503	0.250
473203	470	S	1.187	1.752	1.758	0.252	473414	470	S	0.843	1.624	1.628	0.250
473204	470	S	2.125	2.750	2.756	0.374	473415	470	S	0.843	1.828	1.832	0.312
473205	470	S	1.187	2.125	2.131	0.250	473416	470	S	0.737	1.375	1.379	0.343
473210	470	S	1.313	2.000	2.006	0.313	473419	470	S	1.062	1.828	1.832	0.375
473211	470	S	1.313	2.125	2.131	0.311	473420	470	S	1.062	2.062	2.066	0.375
473212A	470	A	1.313	2.250	2.256	0.311	473421	470	S	1.312	2.106	2.110	0.375
473212	470	S	1.313	2.250	2.256	0.311	473422	470	S	1.312	1.983	1.987	0.375
473213	470	S	1.313	2.374	2.380	0.313	473423	470	S	1.312	1.874	1.878	0.375
473214	470	S	1.375	2.250	2.256	0.311	473424	470	S	1.281	2.000	2.011	0.374
473214A	470	A	1.375	2.250	2.256	0.311	473425	470	S	1.187	1.828	1.832	0.375

Part Number	Style	Matl	Shaft	Bore	O.D.	Width	Part Number	Style	Matl	Shaft	Bore	O.D.	Width
473426	470	S	1.187	1.983	1.987	0.375	473814	470	S	1.968	2.623	2.627	0.312
473427	470	S	1.156	2.062	2.068	0.374	◆473823	470	S	1.378	2.165	2.172	0.315
473428	470	S	1.156	1.984	1.988	0.250				35	55	55.17	8
473435	470	S	1.343	2.106	2.110	0.375	474069	470	S	2.125	2.561	2.565	0.492
473436	470	S	1.343	2.125	2.129	0.375	474127	470	S	1.417	2.250	2.254	0.250
473437	470	S	1.437	2.623	2.627	0.375	474131	470	S	0.750	1.302	1.306	0.250
473438	470	S	1.468	2.375	2.379	0.375	◆474133	470	S	1.575	2.913	2.918	0.394
473439	470	S	1.468	2.437	2.441	0.375				40	74	74.12	10
473440	470	S	1.500	2.750	2.754	0.312	◆474134	470	S	1.969	0.103	2.618	0.512
473441	470	S	1.563	2.750	2.756	0.375				50	2.62	66.50	13
473443	470	S	1.625	2.750	2.754	0.375	◆474161	470	S	1.575	0.101	2.559	0.374
473444	470	S	1.625	2.875	2.881	0.313				40	2.56	65.00	9.50
473444V	470	V	1.625	2.875	2.881	0.313	474216	470	S	1.625	2.562	2.565	0.375
473445	470	S	1.687	2.437	2.441	0.312	474230	470	S	2.875	3.540	3.548	0.315
473446	470	S	1.687	2.875	2.879	0.375	474241V→	470	V	1.654	2.283	2.290	0.276
473447	470	S	1.750	2.758	2.762	0.375	474250	470	S	1.000	1.686	1.692	0.250
473448	470	S	1.750	2.996	3.001	0.375	474252	470	S	0.937	1.752	1.756	0.250
473449	470	S	1.812	2.750	2.754	0.375	474253	470	S	0.812	1.499	1.503	0.250
473450V	470	V	1.812	2.875	2.879	0.375	474254	470	S	1.187	2.437	2.441	0.250
473451	470	S	1.843	2.623	2.627	0.375	474255	470	S	1.187	2.250	2.254	0.250
473452	470	S	1.843	2.750	2.754	0.375	474256	470	S	1.187	2.441	2.445	0.250
473453	470	S	1.843	2.875	2.879	0.375	474260	470	S	1.156	1.686	1.690	0.250
473454	470	S	1.875	2.502	2.506	0.315	474261	470	S	0.687	1.187	1.191	0.187
473455	470	S	1.875	2.835	2.839	0.375	474264	470	S	1.437	2.437	2.441	0.312
473458	470	S	1.875	3.189	3.194	0.375	474265	470	S	1.687	2.686	2.691	0.312
473459	470	S	1.937	2.686	2.690	0.312	474269	470	S	1.937	2.437	2.441	0.250
473460	470	S	1.938	2.996	3.002	0.313	474272	470	S	2.000	2.716	2.721	0.375
473461	470	S	1.937	3.061	3.066	0.375	474273	470	S	0.781	1.828	1.833	0.250
473462	470	S	1.937	3.189	3.194	0.375	474274	470	S	1.625	2.750	2.754	0.312
473463	470	S	2.000	3.061	3.067	0.375	474276	470	S	1.500	1.983	1.989	0.252
473464	470	S	2.000	3.189	3.194	0.375	474277	470	S	0.437	1.124	1.128	0.250
473466	470	S	2.062	2.996	3.001	0.375	474278	470	S	1.250	1.688	1.694	0.252
473467	470	S	2.125	2.996	3.001	0.750	474279N	470	N	0.375	0.836	0.841	0.187
473468	470	S	2.125	3.061	3.067	0.500	474281	470	S	1.500	2.758	2.763	0.312
473471	470	S	2.187	3.062	3.066	0.375	475001	470	S	2.500	3.543	3.548	0.500
473473	470	S	2.250	3.061	3.067	0.375	475003N	470	N	2.625	3.623	3.630	0.469
473474	470	S	2.375	3.061	3.067	0.375	475004H	470	H	2.750	3.751	3.756	0.500
473475	470	S	2.375	3.189	3.194	0.375	475009N	470	N	2.750	3.876	3.883	0.374
473476	470	N	2.500	3.150	3.155	0.315	475012N	470	N	2.937	4.003	4.008	0.468
473490	470	S	1.562	3.150	3.155	0.312	475095	470	S	2.375	3.500	3.505	0.375
473517	470	S	1.562	2.125	2.129	0.375	475095N	470	N	2.375	3.500	3.505	0.375
473546	470	S	0.551	1.000	1.004	0.312	475234N	470	N	2.250	3.623	3.628	0.468
473551	470	S	1.250	2.047	2.058	0.297	475322N	470	N	2.750	3.543	3.550	0.438
473560N→	470	N	1.654	56.000	2.206	0.275	475368N	470	N	2.625	3.500	3.505	0.500
473573	470	S	2.375	3.000	3.005	0.375	475380N	470	N	2.375	3.623	3.628	0.468
◆473677	470	S	1.575	2.165	2.176	0.315	475384	470	S	2.812	4.003	4.008	0.468
			40	55	55.27	8	475458	470	S	2.625	3.623	3.630	0.374
473694	470	S	1.625	2.000	2.004	0.250	475500	470	S	3.298	4.125	4.130	0.562
473796	470	S	1.750	2.565	2.571	0.313	475845	470	S	4.000	4.999	5.004	0.375
473812	470	S	1.312	2.166	2.172	0.375	475960	470	S	2.750	3.876	3.883	0.374

Part Number	Style	Matl	Shaft	Bore	O.D.	Width	Part Number	Style	Matl	Shaft	Bore	O.D.	Width
476023N	470	N	3.000	3.751	3.756	0.375	481181	480	S	1.625	2.125	2.131	0.252
◆476208XX	320	S	1.85 47	2.441 62	2.449 62.20	0.315 8	481181N	480	N	1.625	2.125	2.131	0.252
476281	470	S	2.750	4.125	4.132	0.563	481195	480	S	1.937	2.502	2.506	0.375
476283N	470	N	2.750	4.249	4.254	0.500	481213	480	S	1.190	1.687	1.693	0.252
476424N	470	N	3.500	4.750	4.758	0.500	481224V	480	V	1.000	1.499	1.503	0.250
476470	470	S	3.250	4.249	4.256	0.375	481397	480	S	0.656	1.575	1.579	0.250
476500N	470	N	2.938	3.938	3.945	0.500	481443	480	S	0.781	1.375	1.381	0.252
◆476508XX	320	S	1.85 47	2.559 65	2.567 65.20	0.315 8	481481	480	S	0.668	1.187	1.191	0.185
476512	470	S	1.969	4.331	4.336	0.374	481528	480	S	0.656	1.124	1.128	0.250
476514	470	S	2.556	3.937	3.942	0.375	481537	480	S	0.656	1.250	1.254	0.250
476517	470	S	3.934	5.905	5.911	0.500	481538	480	S	0.687	1.250	1.256	0.250
476518	470	S	4.331	6.693	6.700	0.500	481538V	480	V	0.687	1.250	1.256	0.250
476535	470	S	2.125	3.149	3.154	0.375	481568	480	S	0.781	1.499	1.503	0.250
476574N	470	N	2.750	3.937	3.942	0.500	481571V	480	V	0.937	1.499	1.503	0.250
◆476810XX	320	S	1.85 47	2.677 68	2.688 68.27	0.394 10	481644	480	S	0.781	1.624	1.628	0.250
476820	470	S	1.750	3.937	3.942	0.312	481650	480	S	1.031	1.624	1.628	0.250
476838	470	S	1.125	1.828	1.832	0.312	481652V	480	V	1.125	1.624	1.628	0.250
476842	470	S	5.500	6.250	6.257	0.500	481792	480	S	1.125	2.125	2.129	0.250
◆477010XX	320	S	1.85 47	2.756 70	2.764 70.20	0.394 10	481826	480	S	1.437	2.441	2.445	0.375
477055	470	S	3.330	4.125	4.130	0.562	481834	480	S	1.312	2.502	2.506	0.375
477069	470	S	2.598	4.000	4.005	0.500	481837	480	S	1.500	2.502	2.508	0.375
477163N	470	N	3.000	4.501	4.506	0.468	481859	480	S	1.250	2.686	2.690	0.375
477872	470	S	2.750	-	-	0.315	481864	480	S	1.625	2.686	2.692	0.313
480055	480	S	1.375	2.374	2.380	0.500	481992	480	S	1.812	3.125	3.130	0.375
480067	480	S	1.500	2.502	2.506	0.437	482069N	480	N	0.860	1.437	1.441	0.250
480210	480	S	1.055	1.499	1.500	0.268	482126	480	S	1.750	2.328	2.334	0.438
480281	480	S	1.812	2.758	2.762	0.500	482163	480	S	1.374	1.983	1.989	0.311
480303	480	S	2.125	3.000	3.006	0.500	482163N	480	N	1.374	1.983	1.989	0.311
480356	480	S	1.250	1.687	1.693	0.313	482164N	480	N	1.750	2.502	2.508	0.311
480479H	480	H	1.687	2.437	2.441	0.468	482208	480	S	1.125	1.624	1.630	0.252
480491	480	S	2.750	3.481	3.486	0.500	482230N	480	N	1.250	2.125	2.131	0.251
480519	480	S	2.500	3.251	3.256	0.500	482253	480	S	1.593	2.502	2.506	0.250
480570	480	S	1.375	2.000	2.006	0.311	482258V	480	V	1.375	2.000	2.004	0.312
480574H	480	H	2.375	3.252	3.256	0.500	482267	480	S	1.750	3.153	3.159	0.312
480581	480	S	1.594	2.125	2.129	0.250	482309	480	S	0.968	1.850	1.854	0.375
480625V	480	V	1.500	2.250	2.524	0.312	482310	480	S	0.968	2.048	2.052	0.375
480630	480	S	1.500	2.062	2.066	0.250	482415	480	S	1.496	2.058	2.063	0.250
480821	480	S	0.750	1.312	1.316	0.250	482576N	480	N	1.375	2.125	2.131	0.311
480844	480	S	1.500	2.222	2.226	0.312	483054N	480	N	1.175	1.828	1.832	0.312
480889	480	S	0.812	1.312	1.316	0.250	483230V	480	V	1.625	2.250	2.254	0.312
480954	480	S	0.750	1.250	1.256	0.250	483238V	480	V	1.875	2.875	2.879	0.312
480954V	480	V	0.750	1.250	1.256	0.250	483246N	480	N	2.375	3.251	3.256	0.375
480988H	480	H	2.375	3.061	3.066	0.500	483323V	480	V	2.250	3.000	3.005	0.438
480991	480	S	1.500	2.062	2.066	0.375	483367V	480	V	1.625	2.437	2.441	0.312
481073	480	S	0.656	1.376	1.382	0.250	483488→	480	S	1.175	1.771	1.775	0.275
481163	480	S	1.500	2.000	2.006	0.313	483793	480	S	1.343	2.441	2.445	0.375
							484054	480	S	1.326	2.061	2.065	0.375
							484058	480	S	1.322	2.227	2.231	0.375
							484064V	480	V	2.062	2.561	2.565	0.313
							484156V	480	V	1.375	1.874	1.879	0.250

Part Number	Style	Matl	Shaft	Bore	O.D.	Width	Part Number	Style	Matl	Shaft	Bore	O.D.	Width
484206	480	S	1.618	2.000	2.004	0.235	◆508008XX	350	S	1.969	3.15	3.161	0.315
485027	480	N	3.500	4.999	5.004	0.468	50	80	80.28	8			
485195H	480	H	4.250	5.251	5.256	0.468	◆508508XX	320	S	1.969	3.346	3.354	0.315
485364N	480	N	2.750	3.500	3.505	0.500	50	85	85.20	8			
485497	480	S	3.625	4.875	4.883	0.500	◆509008XX	320	S	1.969	3.543	3.551	0.315
							50	90	90.20	8			
◆486208XX	350	S	1.89	2.441	2.445	0.315	◆509010XX	350	S	1.969	3.543	3.554	0.394
			48	62	62.10	8	50	90	90.28	10			
◆486309XX	470	S	1.89	2.48	2.484	0.354	◆516507XX	470	S	2.008	2.559	2.563	0.276
			48	63	63.09	9	51	65	65.10	7			
◆486510XX	320	S	1.89	2.559	2.571	0.394	◆526509XX	350	S	2.047	2.559	2.571	0.354
			48	65	65.30	10	52	65	65.30	9			
◆486810XX	320	N	1.89	2.677	2.688	0.394	◆526808XX	350	S	2.047	2.677	2.688	0.315
			48	68	68.27	10	52	68	68.28	8			
486857	480	S	2.648	3.812	3.817	0.500	◆526910XX	350	S	2.047	2.717	2.728	0.394
							52	69	69.28	10			
◆487008XX	350	S	1.89	2.756	2.764	0.315	◆527008XX	320	S	2.047	2.756	2.764	0.315
			48	70	70.20	8	52	70	70.20	8			
◆487009XX	350	S	1.89	2.756	2.767	0.354	◆527208XX	350	S	2.047	2.835	2.843	0.315
			48	70	70.28	9	52	72	72.20	8			
◆487207XX	320	S	1.89	2.835	2.847	0.276	◆527512XX	350	S	2.047	2.953	2.964	0.472
			48	72	72.31	7	52	75	75.28	12			
487344V	480	V	2.875	3.751	3.756	0.375	◆528010XX↔	320	S	2.047	3.15	3.161	0.394
487397V→	480	V	3.625	4.624	4.630	0.500	52	80	80.28	10			
							◆528208XX	320	S	2.047	3.228	3.236	0.315
◆487510XX	320	S	1.89	2.953	2.961	0.394	52	82	82.20	8			
			48	75	75.20	10	◆528507XX	320	S	2.047	3.346	3.354	0.315
487945	480	S	2.000	3.623	3.628	0.375	52	85	85.20	8			
◆488008XX	320	S	1.89	3.15	3.157	0.315	◆546508XX	320	S	2.126	2.559	2.567	0.315
			48	80	80.20	8	54	65	65.20	8			
◆489010XX	350	S	1.89	3.543	3.551	0.394	◆547210XX	320	S	2.126	2.835	2.844	0.394
			48	90	90.20	10	54	72	72.25	10			
490936	#	S	1.875	2.567	2.561	0.312	◆547308XX	320	S	2.126	2.874	2.882	0.315
							54	73	73.20	8			
492702	490	S	2.000	2.624	2.630	0.250	◆548210XX	320	S	2.126	3.228	3.242	0.394
493291	490	S	2.281	3.154	3.161	0.375	54	82	82.35	10			
493524	490	S	2.000	2.846	2.850	0.375	◆548510XX	320	S	2.126	3.346	3.357	0.394
493629	490	S	2.321	3.000	3.004	0.313	54	85	85.28	10			
493637	490	S	2.328	3.000	3.006	0.375	◆556808XX	320	S	2.165	2.6767	2.688	0.315
							55	68	68.28	8			
◆494117	490	S	1.654	2.213	2.224	0.236	◆557008XX	350	S	2.1665	2.756	2.767	0.315
			42	56.20	56.49	6	55	70	70.27	8			
◆494122	490	S	1.772	2.441	2.447	0.236	◆557208XX	350	S	2.165	2.835	2.844	0.315
			45	62	62.15	6	55	72	72.25	8			
◆494123	490	S	2.008	2.480	2.487	0.236	◆557508XX	350	S	2.165	2.953	2.961	0.315
			51	63	63.17	6	55	75	75.20	8			
◆506207XX	350	S	1.969	2.441	2.452	0.276	◆557510XX	350	S	2.165	2.953	2.967	0.394
			50	62	62.28	7	55	75	75.35	10			
◆506508XX	320	S	1.969	2.559	2.57	0.315	◆557810XX	350	S	2.165	3.071	3.082	0.394
			50	65	65.28	8	55	78	78.28	10			
◆506808XX	350	S	1.969	2.677	2.688	0.315	◆558008XX	350	S	2.165	3.15	3.161	0.315
			50	68	68.28	8	55	80	80.28	8			
◆507008XX	320	S	1.969	2.756	2.764	0.315	◆558212XX	350	S	2.165	3.228	3.24	0.472
			50	70	70.20	8	55	82	82.30	12			
◆507009XX	320	S	1.969	2.756	2.764	0.354	◆558510XX	350	S	2.165	3.346	3.359	0.394
			50	70	70.20	9	55	85	85.31	10			
◆507208XX	350	S	1.969	2.835	2.846	0.315	◆558808XX↔	320	S	2.165	3.465	3.472	0.315
			50	72	72.28	8	55	88	88.20	8			
◆507507XX	320	S	1.969	2.953	2.961	0.276	◆559013XX	350	S	2.165	3.543	3.554	0.512
			50	75	75.20	7	55	90	90.28	13			
◆507512XX	320	S	1.969	2.953	2.964	0.472							
			50	75	75.28	12							

Part Number	Style	Matl	Shaft	Bore	O.D.	Width	Part Number	Style	Matl	Shaft	Bore	O.D.	Width
◆566810XX	480	N	2.205 56	2.677 68	2.682 68.12	0.394 10	◆638510XX	320	S	2.48 63	3.346 85	3.357 85.28	0.394 10
◆567008XX	350	S	2.205 56	2.756 70	2.764 70.20	0.315 8	◆639010XX	320	S	2.48 63	3.543 90	3.549 90.14	0.394 10
◆567207XX	320	S	2.205 56	2.835 72	2.843 72.20	0.276 7	◆648008XX	320	S	2.52 64	3.15 80	3.161 80.28	0.315 8
◆567507XX	320	S	2.205 56	2.953 75	2.961 75.20	0.276 7	◆658008XX	320	S	2.559 65	3.15 80	3.161 80.28	0.315 8
◆568008XX	320	S	2.205 56	3.15 80	3.161 80.28	0.315 8	◆658508XX	350	S	2.559 65	3.346 85	3.354 85.20	0.315 8
◆568208XX	320	S	2.205 56	3.228 82	3.236 82.20	0.315 8	◆658510XX	350	S	2.559 65	3.346 85	3.357 85.27	0.394 10
◆568508XX	350	S	2.205 56	3.346 85	3.357 85.28	0.315 8	◆658808XX	350	S	2.559 65	3.465 88	3.472 88.20	0.315 8
◆568808XX	320	S	2.205 56	3.465 88	3.472 88.20	0.315 8	◆658810XX	320	S	2.559 65	3.465 88	3.472 88.20	0.394 10
◆569008XX	320	S	2.205 56	3.543 90	3.551 90.20	0.315 8	◆659007XX	320	S	2.559 65	3.543 90	3.551 90.20	0.276 7
◆578513XX	320	S	2.244 57	3.346 85	3.354 85.20	0.512 13	◆659010XX	350	S	2.559 65	3.543 90	3.554 90.28	0.394 10
◆587208XX	350	S	2.283 58	2.835 72	2.846 72.28	0.315 8	◆659013XX	350	S	2.559 65	3.543 90	3.551 90.20	0.512 13
◆587511XX	350	S	2.283 58	2.953 75	2.964 75.28	0.433 11	◆688207XX	350	S	2.677 68	3.228 82	3.236 82.20	0.276 7
◆588008XX	350	S	2.283 58	3.15 80	3.161 80.28	0.315 8	◆688508XX	350	S	2.677 68	3.346 85	3.354 85.20	0.315 8
◆588513XX	320	S	2.283 58	3.346 85	3.356 85.25	0.512 13	◆689007XX	320	S	2.677 68	3.543 90	3.551 90.20	0.276 7
◆588808XX	320	S	2.283 58	3.465 88	3.472 88.20	0.315 8	◆689010XX	350	S	2.677 68	3.543 90	3.556 90.32	0.394 10
◆589010XX	350	S	2.283 58	3.543 90	3.554 90.28	0.394 10	◆689510XX	350	S	2.677 68	3.74 95	3.748 95.20	0.394 10
◆607208XX	350	S	2.362 60	2.835 72	2.846 72.28	0.315 8	◆708508XX	350	S	2.756 70	3.346 85	3.357 85.28	0.315 8
◆607508XX	350	S	2.362 60	2.953 75	2.964 75.28	0.315 8	◆708808XX	480	S	2.756 70	3.465 88	3.474 88.25	0.315 8
◆608008XX	350	S	2.362 60	3.15 80	3.157 80.20	0.315 8	◆708812XX	320	S	2.756 70	3.465 88	3.474 88.25	0.472 12
◆608207XX	320	S	2.362 60	3.228 82	3.236 82.20	0.276 7	◆709007XX	320	S	2.756 70	3.543 90	3.551 90.20	0.276 7
◆608212XX	350	S	2.362 60	3.228 82	3.24 82.30	0.472 12	◆709010XX	350	S	2.756 70	3.543 90	3.556 90.32	0.394 10
◆608508XX	350	S	2.362 60	3.346 85	3.357 85.28	0.315 8	◆709212XX	320	S	2.756 70	3.622 92	3.63 92.20	0.472 12
◆608512XX	320	S	2.362 60	3.346 85	3.354 85.20	0.472 12	◆709510XX	350	S	2.756 70	3.74 95	3.751 95.28	0.394 10
◆609008XX	320	S	2.362 60	3.543 90	3.553 90.25	0.315 8	◆709513XX	350	S	2.756 70	3.74 95	3.751 95.28	0.512 13
◆609010XX	350	S	2.362 60	3.543 90	3.554 90.27	0.394 10	710005	860	S	1.750	3.062	3.066	0.485
◆609508XX	320	S	2.362 60	3.74 95	3.748 95.20	0.315 8	710006→	740	N	2.375	4.500	4.504	1.060
◆628009XX	320	S	2.441 62	3.15 80	3.157 80.20	0.315 9	710007	#	S	2.000	3.370	-	1.020
◆628010XX	350	S	2.441 62	3.15 80	3.161 80.28	0.394 10	710008	740	N	3.000	5.750	5.758	0.449
◆628508XX	410	S	2.441 62	3.346 85	3.352 85.13	0.315 8	710009	#	U	3.000	4.000	4.004	0.656
◆629010XX	350	S	2.441 62	3.543 90	3.554 90.28	0.394 10	710010	#	U	2.750	3.750	3.756	0.500
							710011	#	U	3.000	4.000	4.008	0.500
							710012	#	U	1.500	2.250	2.254	0.375
							710013	#	U	1.750	2.438	2.441	0.375
							710014	#	U	1.250	1.750	1.754	0.250

Part Number	Style	Matl	Shaft	Bore	O.D.	Width	Part Number	Style	Matl	Shaft	Bore	O.D.	Width
710015	#	U	3.500	4.500	4.506	0.500	◆710072	#	S	2.244 57	3.110 79	3.120 79.25	0.539 13.70
710016	#	U	3.250	4.250	4.255	0.500							
710017	#	U	2.000	2.688	2.690	0.375	◆710073	#	S	2.126 54	2.972 75.50	2.983 75.78	0.709 18
710018	#	U	2.500	3.250	3.255	0.375	◆710074	#	S	2.244 57	3.110 79	3.120 79.25	0.539 13.70
710019	#	U	1.875	2.875	2.878	0.625	710075←	320	V	2.832	3.622	3.633	0.374
							710076	#	S	1.350	1.620	1.625	0.355
710020	#	U	1.500	2.250	2.253	0.500	710077	320	S	3.375	3.948	3.955	0.375
710022	450	H	4.000	4.998	5.006	0.500	◆710078	470	V	1.772 45	2.441 62	2.447 62.15	0.315 8
710023	#	U	1.500	2.000	2.004	0.250	710080	#	S	3.125	4.450	4.456	0.880
710024	#	U	1.750	2.250	2.254	0.250	710081	#	S	1.937	3.930	3.935	0.320
710025	#	U	2.000	2.500	2.504	0.250	710084	470	S	4.724	5.512	5.520	0.413
							710086	#	S	2.205	4.803	4.813	0.315
710026	#	U	2.250	2.750	2.754	0.250	710087	450	S	2.953	4.409	4.416	0.394
710027	#	U	2.500	3.000	3.004	0.313	710088	#	S	3.330	5.045	5.050	0.800
710028	#	U	3.000	3.500	3.505	0.313	710089	#	S	4.646	6.811	6.843	1.102
710029	#	U	3.500	4.000	4.005	0.313	710090	#	S	3.040	6.412	6.418	0.658
710030	#	U	3.500	4.125	4.130	0.312	710091	2720	S	2.688	3.499	3.504	0.344
							◆710092	410	S	2.598 66	3.346 85	3.353 85.17	0.315 8
710031	#	U	4.000	4.750	4.756	0.313	◆710093	#	S	2.362 60	2.953 75	2.959 75.16	0.228 5.80
710032	#	U	5.000	5.750	5.756	0.313	◆710094	660	S	2.559 65	3.228 82	3.235 82.17	0.276 7
710034	#	U	2.500	3.000	3.015	0.375	710096	740	N	1.378	2.240	2.247	2.540
710035	#	U	3.750	4.375	4.381	0.313	◆710097	#	S	1.654 42	2.205 56	2.216 56.29	0.276 7
710036	#	U	4.000	4.625	4.631	0.313	◆710098	710	S	1.969 50	2.524 64.10	2.535 64.39	0.256 6.50
							710101↔	#	S	1.250	2.402	2.408	0.228
710037	#	A	4.750	5.375	5.381	0.313	710102	#	S	1.625	2.410	2.440	0.361
710038	#	U	2.750	3.250	3.255	0.313	710105↔	#	S	1.705	3.084	3.090	0.461
710039	#	U	2.735	3.415	-	0.340	710106	#	S	3.133	3.547	3.551	0.366
710040	#	U	2.000	2.500	2.501	0.375	◆710107	#	S	2.047 52	3.087 78.40	3.090 78.49	0.386 9.80
710041	#	U	2.375	2.875	2.879	0.375	◆710108	660	S	2.205 56	2.992 76	2.998 76.15	0.193 4.90
							◆710109↔	400	N	1.339 34	2.480 63	2.491 63.27	0.354 9
710042	#	U	2.485	3.165	2.488	0.188	◆710110↔	400	N	1.339 34	2.126 54	2.137 54.28	0.354 9
710043	#	S	1.301	2.620	2.625	0.315	◆710111←	#	N	1.378 35	1.969 50	1.980 50.29	0.453 11.50
710044	#	S	1.500	1.875	-	0.188	◆710112↔	#	N	1.969 50	3.150 80	3.161 80.30	0.650 16.50
710045	VS1	S	2.250	-	2.840	0.500	710113	#	S	1.575	2.953	2.965	0.472
710046→	860	S	1.552	2.447	2.452	0.500	◆710114→	980	N	1.614 41	2.323 59	2.334 59.28	0.394 10
◆710051	860	S	1.378 35	1.890 48	1.895 48.13	0.512 13	◆710115↔	980	S	1.732 44	3.150 80	3.161 80.29	0.343 8.70
710053	480	S	1.047	1.811	1.815	0.285	◆710116	320	N	0.551 14	0.984 25	0.993 25.22	0.276 7
◆710056←	470	V	3.583 91	4.370 111	4.381 111.28	0.394 10	◆710117	400	N	1.969 50	3.386 86	3.398 86.30	0.512 13
◆710057	480	S	1.417 36	2.559 65	2.567 65.20	0.315 8							
710058	480	S	1.938	2.562	2.566	0.317							
◆710060←	320	H	3.740 95	4.646 118	4.657 118.29	0.394 10							
710062	#	S	1.750	2.374	2.378	0.484							
710063	#	N	1.625	2.441	2.444	0.500							
◆710064	#	S	2.047 52	2.677 68	2.683 68.15	0.295 7.50							
710066	830	S	1.400	2.478	2.486	0.521							
710067↔	690	S	1.705	3.034	3.040	0.500							
710068	#	S	1.192	2.122	2.128	0.350							
◆710069	#	S	2.205 56	2.835 72	2.841 72.16	0.429 10.90							
◆710070	470	S	1.299 33	1.732 44	1.738 44.15	0.315 8							

Part Number	Style	Matl	Shaft	Bore	O.D.	Width	Part Number	Style	Matl	Shaft	Bore	O.D.	Width
◆710118	400	S	1.535 39	2.323 59	2.334 59.28	0.669 17	◆710154	320	S	0.748 19	1.496 38	1.505 38.23	0.276 7
710119	320	N	1.102	1.693	1.702	0.315							
710120	#	N	1.535	1.969	1.980	0.433	◆710156	320	S	0.709 18	1.260 32	1.269 32.23	0.276 7
◆710121	#	N	2.323 59	3.937 100	3.948 100.28	0.394 10	◆710157→	320	S	1.063 27	1.693 43	1.702 43.23	0.276 7
◆710122	400	N	1.535 39	2.244 57	2.255 57.28	0.610 15.50	◆710159	#	S	1.693 43	2.302 58.47	2.308 58.62	0.295 7.50
◆710123	400	N	1.535 39	2.244 57	2.255 57.28	0.433 11	710160	#	S	1.772	2.598	2.608	0.295
◆710124	400	N	1.299 33	2.323 59	2.334 59.28	0.433 11	◆710161	2810	S	1.811 46	2.697 68.50	2.702 68.63	0.295 7.50
◆710125	#	S	2.205 56	2.921 74.20	2.928 74.37	0.256 6.50	◆710162	480	V	1.260 32	1.969 50	1.974 50.14	0.315 8
◆710126	#	S	1.811 46	0.108 2.73	2.732 69.40	0.433 11	710163	#	S	1.875	-	2.650	0.350
◆710127	#	S	2.165 55	2.677 68	2.683 68.15	0.256 6.50	◆710164	480	V	1.260 32	1.969 50	1.974 50.14	0.315 8
710128	#	S	1.811	2.732	2.740	0.394	710166↔	740	S	1.399	2.292	2.298	0.500
◆710129	#	S	2.244 57	3.031 77	3.039 77.20	0.315 8	◆710167	#	S	1.890 48	2.520 64	2.528 64.20	0.394 10
◆710130	#	S	2.520 64	3.031 77	3.039 77.20	0.315 8	◆710168	470	S	2.323 59	2.953 75	2.957 75.11	0.394 10
◆710131	#	S	1.575 40	2.441 62	2.449 62.20	0.354 9	710171	#	N	2.200	2.804	-	0.300
◆710132	400	N	1.299 33	2.205 56	2.216 56.29	0.512 13	710172	350	V	1.220	1.654	1.661	0.315
◆710133	#	N	1.654 42	3.543 90	3.554 90.27	0.374 9.50	◆710173	#	N	1.969 50	2.756 70	2.764 70.20	0.394 10
◆710135	#	S	1.969 50	2.756 70	2.764 70.20	0.551 14	710174	470	S	2.748	3.881	3.885	0.464
710136	#	S	2.283	2.953	2.961	0.276	◆710175	320	S	2.087 53	0.106 2.69	2.685 68.20	0.276 7
710137	#	S	1.969	2.913	2.921	0.354	◆710176	870	S	2.205 56	2.913 74	2.920 74.17	0.335 8.50
710138	400	S	1.378	2.480	2.488	0.354	◆710178	#	S	1.378 35	1.929 49	1.941 49.30	0.315 8
◆710139	#	N	1.496 38	2.283 58	2.294 58.27	0.394 10	710179→	320	S	1.654	2.551	2.555	0.531
710140	320	S	1.594	2.283	2.293	0.315	710180	470	V	3.250	3.879	3.881	0.375
710141	#	N	1.614	2.402	2.409	0.394	◆710182	660	S	2.362 60	3.386 86	3.393 86.18	0.276 7
◆710142	#	S	1.693 43	2.756 70	2.762 70.16	0.354 9	710183	660	S	2.240	2.992	2.998	0.255
◆710143	#	S	1.850 47	3.307 84	3.318 84.28	0.374 9.50	710186	#	S	1.654	2.216	2.222	0.315
◆710144←	#	S	2.283 58	3.071 78	3.082 78.28	0.394 10	◆710187→	320	N	2.047 52	2.756 70	2.767 70.28	0.335 8.50
◆710147	#	S	1.575 40	2.362 60	2.368 60.15	0.315 8	◆710188←	320	V	3.465 88	4.173 106	4.184 106.27	0.335 8.50
◆710148	970	S	1.929 49	2.843 72.20	2.854 72.49	0.236 6	◆710189←	470	V	3.504 89	4.134 105	4.145 105.28	0.394 10
◆710149	#	S	1.457 37	2.047 52	2.053 52.15	0.236 6	◆710190	480	V	2.047 52	2.677 68	2.683 68.15	0.315 8
◆710150	#	S	1.850 47	3.150 80	3.156 80.16	0.500 12.70	710191	250	S	1.850	2.520	2.523	0.276
◆710151	470	S	1.339 34	2.559 65	2.563 65.10	0.472 12	◆710192	320	S	1.969 50	2.362 60	2.373 60.27	0.236 6
◆710152	#	S	1.417 36	2.520 64	2.526 64.16	0.433 11	◆710193	320	S	1.772 45	2.323 59	2.334 59.28	0.315 8
710153	#	S	1.024	1.732	1.740	0.315	◆710194	320	S	1.969 50	2.677 68	2.681 68.10	0.256 6.50
							710195	400	S	1.654	2.992	3.003	0.472
							710196	320	V	1.575	2.441	2.452	0.394
							710197	400	N	1.417	2.126	2.137	0.276

Part Number	Style	Matl	Shaft	Bore	O.D.	Width	Part Number	Style	Matl	Shaft	Bore	O.D.	Width
710198	#	S	1.565	2.372	2.383	0.394	◆710240	#	S	2.953 75	3.268 83	3.425 87.00	0.157 4
◆710199↔	#	N	1.378 35	2.126 54	2.132 54.15	0.354 9	710241	680	S	1.627	2.277	2.283	0.342
◆710201	470	S	1.378 35	2.362 60	2.368 60.15	0.472 12	◆710242→	320	N	2.047 52	2.835 72	2.846 72.29	0.315 8
710202	680	S	1.627	2.125	2.131	0.342	710243	250	S	0.630	1.024	1.028	0.276
710204	480	S	1.625	2.282	2.286	0.313	710244	#	S	1.654	2.224	2.232	0.315
710205	320	V	3.780	4.606	4.617	0.472	◆710245→	#	N	1.654 42	2.992 76	2.998 76.15	0.472 12
710207	400	S	1.654	2.835	2.846	0.394	◆710246	#	N	1.654 42	3.543 90	3.554 90.27	0.469 11.90
◆710208	#	S	1.693 43	3.622 92	3.633 92.28	0.492 12.50	710247←	#	N	1.504	1.937	1.950	0.475
710209	#	N	1.496	2.441	2.450	0.512	◆710248→	660	N	1.772 45	3.071 78	3.077 78.16	0.433 11
710210	740	V	2.375	3.251	3.256	0.625	◆710249	970	S	0.787 20	1.024 26	1.033 26.24	0.157 4
710211→	740	N	1.875	2.677	2.683	0.374	◆710251	470	N	0.669 17	1.339 34	1.344 34.14	0.311 7.90
◆710213	2810	S	2.441 62	3.071 78	3.077 78.16	0.374 9.50	◆710252	320	S	1.417 36	1.732 44	1.741 44.22	0.197 5
710214	400	N	1.535	2.323	2.334	0.433	◆710253	#	S	2.047 52	2.441 62	2.452 62.28	0.217 5.50
◆710215	660	S	1.850 47	2.598 66	2.602 66.10	0.236 6	◆710254	340	S	0.906 23	1.252 31.80	1.261 32.03	0.217 5.50
710216	350	S	1.102	1.673	1.682	0.315	◆710255	#	S	1.890 48	2.756 70	2.764 70.20	0.354 9
◆710217	#	S	1.378 35	2.126 54	2.132 54.15	0.315 8	710256	#	S	2.520	2.992	3.000	0.276
◆710218	#	V	1.378 35	2.205 56	2.216 56.29	0.394 10	◆710258←	320	V	4.528 115	5.315 135	5.329 135.36	0.394 10
710219←	320	N	3.543	4.252	4.261	0.394	◆710259↔	320	V	1.457 37	2.205 56	2.216 56.29	0.354 9
◆710220→	320	N	1.614 41	2.441 62	2.450 62.23	0.354 9	◆710260←	320	S	1.772 45	2.402 61	2.413 61.29	0.315 8
710221	#	N	1.654	2.205	2.209	0.551	710262	320	V	3.780	4.567	4.577	0.354
710222	980	S	0.709	1.024	1.028	0.157	710263	320	V	2.000	2.623	2.627	0.256
710223	#	S	1.732	2.598	2.602	0.236	◆710264→	320	Y	1.693 43	2.165 55	2.176 55.27	0.236 6
710224	490	S	1.496	2.441	2.445	0.236	◆710266	#	S	3.661 93	6.063 154	6.071 154.20	0.315 8
710225	#	S	2.244	3.150	3.154	0.315	710267	320	S	1.181	2.126	2.134	0.354
◆710226	320	S	1.969 50	0.101 65.30	2.638 67.00	0.217 5.50	710268	400	N	2.283	4.055	4.063	0.433
◆710228	400	S	1.457 37	2.441 62	2.450 62.23	0.394 10	710270	320	N	1.772	2.835	2.843	0.472
710229	400	S	2.323	3.083	3.093	0.315	◆710271←	320	S	2.283 58	2.913 74	2.924 74.27	0.394 10
◆710230	#	S	2.283 58	2.992 76	3.001 76.23	0.307 7.80	710272	320	N	0.736	1.378	1.386	0.276
710231	320	S	2.323	3.083	3.093	0.315	◆710273	350	S	0.748 19	1.378 35	1.387 35.23	0.394 10
◆710232	320	V	3.386 86	4.094 104	4.109 104.37	0.433 11	710274	680	V	0.610	1.102	1.108	0.598
710233→	320	N	1.516	2.087	2.096	0.315	710275	400	N	2.677	4.882	4.886	0.472
◆710234←	320	N	2.677 68	3.307 84	3.318 84.28	0.335 8.50	◆710276	400	N	2.362 60	4.055 103	4.062 103.18	0.472 12
◆710235←	320	V	3.386 86	4.055 103	4.066 103.28	0.394 10	710277	#	N	2.520	5.197	5.201	0.512
◆710236→	320	N	1.299 33	1.929 49	1.938 49.23	0.315 8	710278	#	N	3.937	5.709	5.713	1.024
◆710237←	320	V	3.543 90	4.094 104	4.105 104.27	0.433 11	710281	740	S	1.940	2.900	2.910	0.400
◆710238→	320	S	1.811 46	2.756 70	2.760 70.10	0.315 8	◆710282	320	S	1.260 32	1.654 42	1.661 42.20	0.315 8
◆710239	400	N	2.126 54	2.717 69	2.726 69.23	0.295 7.50	710283	#	N	1.732	3.543	3.547	0.354

Part Number	Style	Matl	Shaft	Bore	O.D.	Width	Part Number	Style	Matl	Shaft	Bore	O.D.	Width
◆710284	#	N	1.575 40	2.874 73	2.878 73.10	0.492 12.50	710318	320	N	1.516	2.283	2.291	0.335
710285	#	S	1.125	1.630	1.634	0.313	◆710320	480	S	1.890 48	2.441 62	2.445 62.10	0.354 9
◆710286	320	N	1.654 42	2.638 67	2.646 67.20	0.394 10	710321	470	S	1.772	2.441	2.445	0.354
710287	320	N	1.575	2.126	2.134	0.394	◆710322	340	S	1.890 48	2.441 62	2.452 62.28	0.236 6
◆710288←	320	S	3.661 93	4.488 114	4.500 114.30	0.512 13	◆710323	490	S	2.008 51	2.480 63	2.487 63.17	0.236 6
◆710289→	320	S	1.772 45	2.638 67	2.644 67.16	0.315 8	◆710324←	320	S	1.378 35	1.969 50	1.978 50.24	0.433 11
710290	320	V	3.937	4.882	4.890	0.512	◆710325→	320	S	1.102 28	1.575 40	1.584 40.23	0.315 8
◆710291←	400	N	1.614 41	2.480 63	2.488 63.20	0.354 9	◆710326	660	S	1.575 40	2.520 64	2.526 64.16	0.472 12
◆710292	#	S	2.047 52	2.677 68	2.683 68.15	0.256 6.50	◆710327→	320	S	1.260 32	1.890 48	1.899 48.24	0.276 7
710293	#	S	3.209	3.535	-	0.091	◆710328	350	S	1.299 33	1.969 50	1.978 50.24	0.276 7
710294	470	S	3.307	3.937	3.941	0.394	◆710329←	320	H	1.378 35	1.969 50	1.980 50.29	0.315 8
710295	470	S	4.173	4.843	4.846	0.433	710330	#	N	3.346	4.449	4.457	0.413
710296	#	S	1.890	4.272	4.280	0.512	◆710331←	320	V	1.378 35	2.126 54	2.134 54.20	0.315 8
◆710297	340	S	0.709 18	0.906 23	0.915 23.24	0.157 4	◆710332←	320	N	1.220 31	1.811 46	1.820 46.23	0.315 8
◆710298→	400	N	1.654 42	2.480 63	2.491 63.27	0.354 9	710333	320	S	2.362	3.150	3.157	0.315
◆710299	660	N	0.689 18	1.083 27.50	1.092 27.74	0.276 7	◆710334←	320	N	2.677 68	3.386 86	3.397 86.28	0.315 8
◆710300	#	S	1.575 40	2.185 55.50	2.191 55.65	0.354 9	◆710335	320	S	1.378 35	2.559 65	2.570 65.28	0.472 12
710301	970	S	1.654 1.654	2.441 -	2.449 42.29	0.276 8.00	◆710336←	400	N	1.378 35	2.677 68	2.685 68.20	0.354 9
710303	350	S	1.004	1.516	1.525	0.335	◆710337	340	S	1.850 47	2.843 72.20	2.854 72.49	0.236 6
710304	#	S	1.479	2.563	2.567	0.470	◆710338	660	S	1.535 39	2.047 52	2.053 52.15	0.248 6.30
◆710305	320	S	1.929 49	2.756 70	2.767 70.28	0.433 11	◆710339	250	S	2.756 70	4.409 112	4.416 112.17	0.551 14
◆710305S	320	S	1.929 49	2.756 70	2.767 70.28	0.433 11	710340	440	V	1.189	1.654	1.657	0.236
710306	320	S	1.260	2.047	2.055	0.394	◆710341←	320	S	1.417 36	1.969 50	1.980 50.29	0.315 8
710307	320	N	0.984	1.575	1.583	0.276	◆710342→	320	S	0.787 20	1.850 47	1.859 47.22	0.335 8.50
◆710308→	320	S	1.575 40	2.047 52	2.058 52.27	0.236 6	◆710343	330	S	1.417 36	1.811 46	1.817 46.15	0.354 9
◆710309	#	S	1.496 38	2.047 52	2.053 52.15	0.248 6.30	◆710344	320	S	0.685 17	1.181 30	1.190 30.23	0.276 7
◆710310→	320	N	1.260 32	1.850 47	1.859 47.22	0.236 6	◆710345	320	S	1.772 45	2.677 68	2.685 68.20	0.472 12
◆710311	250	S	1.575 40	2.126 54	2.132 54.15	0.236 6	◆710346	490	S	0.591 15	0.787 20	0.791 20.10	0.197 5
◆710312	320	S	2.047 52	2.677 68	2.685 68.20	0.512 13	◆710347←	320	S	1.102 28	1.496 38	1.505 38.23	0.394 10
◆710313→	320	S	1.890 48	2.756 70	2.767 70.28	0.472 12	◆710348	320	S	0.512 13	0.866 22	0.874 22.20	0.236 6
◆710314←	400	N	1.378 35	2.205 56	2.216 56.29	0.315 8	710349	#	V	4.134	5.315	5.323	0.571
◆710315→	400	S	1.378 35	2.205 56	2.216 56.29	0.315 8	710350	#	V	2.362	3.228	3.236	0.472
◆710316→	320	S	0.984 25	1.575 40	1.584 40.23	0.315 8							
◆710317←	320	S	1.260 32	1.890 48	1.899 48.24	0.394 10							

Part Number	Style	Matl	Shaft	Bore	O.D.	Width	Part Number	Style	Matl	Shaft	Bore	O.D.	Width
◆710351←	320	H	3.937 100	5.315 135	5.329 135.36	0.394 10	◆710383	470	S	1.378 35	1.732 44	1.738 44.15	0.276 7
◆710352	470	V	3.740 95	4.449 113	4.453 113.10	0.394 10	◆710384	250	S	2.953 75	3.937 100	3.944 100.18	0.512 13
◆710353→	660	S	1.457 37	2.283 58	2.287 58.10	0.394 10	710385	#	S	1.675	2.000	2.175	0.200
◆710354→	320	N	1.969 50	2.559 65	2.570 65.28	0.315 8	710386→	320	H	1.650	2.205	2.216	0.276
◆710355→	320	N	1.457 37	1.988 50.50	1.996 50.70	0.236 6	710387	470	S	1.693	2.531	2.565	0.374
◆710356→	470	S	1.890 48	2.362 60	2.368 60.15	0.354 9	710388↔	320	S	1.875	2.716	2.727	0.394
◆710357	470	S	1.969 50	2.638 67	2.646 67.20	0.354 9	710389	70S	S	1.750	2.500	2.503	0.484
710358	450	N	1.625	2.374	2.380	0.311	◆710390→	320	N	2.362 60	3.228 82	3.236 82.20	0.472 12
710358N	480	S	1.625	2.374	2.380	0.311	710391←	940	H	3.937	5.315	5.323	0.591
◆710359	#	S	1.181 30	1.772 45	1.780 45.20	0.315 8	710393	#	S	2.205	2.835	2.843	0.315
◆710360	350	S	1.378 35	2.835 72	2.846 72.29	0.394 10	710394	#	S	1.811	2.441	2.449	0.807
710361	440	S	0.669	0.819	0.823	0.122	710395	Unitized	S	2.750	3.779	3.784	0.762
◆710362	490	S	0.669 17	0.984 25	0.990 25.15	0.197 5	◆710396↔	400	S	1.378 35	2.205 56	2.213 56.20	0.354 9
710363←	#	V	3.307	4.646	4.650	0.276	710397	#	N	1.831	3.543	3.551	0.472
◆710364↔	#	N	1.772 45	3.858 98	3.865 98.17	0.413 10.50	◆710398	#	S	1.969 50	2.835 72	2.843 72.20	0.394 10
710365	#	S	2.000	2.720	-	0.210	710399→	320	S	1.024	1.654	1.661	0.315
◆710366←	320	H	4.173 106	4.961 126	4.975 126.37	0.472 12	◆710400	470	S	2.283 58	2.953 75	2.959 75.16	0.354 9
◆710367→	400	S	2.559 65	3.465 88	3.472 88.20	0.472 12	710401	#	S	1.181	1.457	1.461	0.138
◆710368	470	S	5.433 138	5.984 152	5.992 152.20	0.472 12	710402	#	S	1.614	2.677	2.685	0.512
◆710369	470	S	5.709 145	6.457 164	10.398 264.10	0.551 14	◆710403	#	S	1.654 42	2.441 62	2.445 62.10	0.472 12
◆710370	320	S	1.260 32	1.693 43	1.702 43.23	0.276 7	710405	470	S	4.882	5.748	5.752	0.551
◆710371	250	S	3.976 101	4.488 114	4.492 114.10	0.394 10	◆710406	470	S	5.512 140	6.693 170	6.701 170.21	0.551 14
◆710372	#	S	4.528 115	6.142 156	6.146 156.10	0.610 15.50	◆710407	330	S	2.008 51	2.441 62	2.446 62.13	0.276 7
◆710373	470	S	2.559 65	3.346 85	3.353 85.17	0.394 10	◆710408	320	N	1.654 42	2.441 62	2.452 62.28	0.276 7
◆710374	#	S	1.929 49	3.937 100	3.945 100.20	0.315 8	710409	#	S	1.813	2.408	-	0.300
◆710375	#	S	2.992 76	4.016 102	4.024 102.20	0.374 9.50	◆710410	470	S	3.937 100	4.488 114	4.496 114.20	0.472 12
710376	#	S	2.953	4.409	4.413	0.394	710411	470	S	5.039	5.748	5.752	0.394
710377	#	S	1.811	3.720	3.728	0.315	◆710412	320	S	0.709 18	1.339 34	1.348 34.24	0.276 7
710378	350	S	2.677	3.228	3.236	0.276	710413	#	N	2.172	3.125	3.130	0.675
◆710379	470	S	2.362 60	2.835 72	2.841 72.16	0.295 7.50	710414	#	T	1.500	2.500	2.500	0.375
◆710380	470	S	5.118 130	5.906 150	5.914 150.22	0.394 10	◆710415→	320	S	1.260 32	1.969 50	1.978 50.24	0.315 8
◆710381	#	S	4.882 124	6.693 170	-	0.571 14.50	◆710416	350	S	1.339 34	1.890 48	1.899 48.24	0.295 7.50
◆710382	#	S	2.205 56	2.598 66	2.606 66.20	0.669 17	◆710418	320	N	1.339 34	2.087 53	2.098 53.29	0.315 8
							710419	#	S	1.378	2.480	2.491	0.394
							◆710420→	320	S	1.969 50	2.677 68	2.688 68.28	0.354 9
							◆710422	350	S	1.339 34	2.441 62	2.452 62.28	0.394 10
							◆710424	350	S	1.378 35	2.362 60	2.373 60.27	0.315 8
							710425	2300	S	5.428	6.500	6.505	0.420

Part Number	Style	Matl	Shaft	Bore	O.D.	Width	Part Number	Style	Matl	Shaft	Bore	O.D.	Width
710426	#	S	1.465	2.372	2.374	0.433	712017	#	S	0.625	1.124	1.128	0.375
710428	870	V	1.750	2.621	2.625	0.937							
710429	870	V	1.380	2.288	2.291	0.750							
710430	#	S	2.325	3.125	3.130	0.313	712018	#	S	0.984	1.596	1.600	0.250
710431	#	S	1.693	2.480	2.488	0.394	712019	#	S	0.500	0.875	0.879	0.313
710432	320	S	1.575	2.244	2.252	0.394	◆712020←	320	N	1.575 40	2.953 75	2.964 75.29	0.472 12
710433	#	S	1.102	2.087	2.091	0.378	712021	#	S	0.312	0.749	0.753	0.250
710435	320	S	1.496	2.559	2.567	0.315	712022	#	S	0.312	0.689	0.690	0.313
710436	350	N	1.594	2.067	2.075	0.236	712023	#	V	1.500	2.311	2.315	0.500
710437	470	S	1.969	2.953	2.957	0.354	712024	#	S	0.625	1.124	1.128	0.375
710438	#	S	2.126	2.992	3.000	0.551	712025	470	S	1.250	1.752	1.758	0.252
710439	#	S	2.283	2.874	2.878	0.335	712026	#	S	1.000	1.375	1.379	0.250
◆710440	470	S	2.677 68	3.543 90	3.550 90.17	0.472 12	712027	#	S	0.750	1.250	1.254	0.250
710441	#	N	1.500	2.377	2.388	0.433	712028	#	S	0.562	0.750	0.754	0.094
◆710442→	480	N	1.654 42	2.323 59	2.329 59.16	0.303 7.70	712100←	TPDW	T	3.125	3.750	3.768	0.437
710443	#	N	1.575	2.161	2.165	0.512	712101→	TFW-H	T	2.325	3.375	3.390	0.375
◆710444←	320	S	1.575 40	2.126 54	2.137 54.28	0.236 6	712102→	TFW-H	T	1.875	2.625	2.640	0.433
◆710445	350	S	0.748 19	1.378 35	1.387 35.23	0.315 8	712103→	TPDW	T	2.625	3.516	3.533	0.394
◆710446→	350	S	2.677 68	3.465 88	3.476 88.29	0.315 8	712104→	TPDW	T	1.102	1.496	1.506	0.276
710562	2300	S	6.775	7.875	7.880	0.360	712105←	TW	T	3.937	4.724	4.734	0.433
710800	2300	S	9.466	10.875	10.891	0.375	712106	320	T	4.724	5.512	5.520	0.512
710925	2300	S	11.006	12.875	12.891	0.625	712107→	TFW-H	T	4.134	5.118	5.124	0.433
711000	2300	S	11.586	13.687	13.703	0.562	712108→	TFW-H	T	2.677	3.543	3.549	0.394
711200	2300	S	13.797	15.500	15.513	0.437	712109←	TFW-H	T	5.000	6.000	6.016	0.591
711552	470	N	1.562	2.502	2.506	0.312	712110←	TW	T	6.142	7.087	7.094	0.591
711553	740	N	2.375	3.875	3.881	1.060	712111→	TFW-H	T	3.150	3.937	3.953	0.394
712000	#	N	3.000	5.750	5.764	0.413	712112←	TW	T	4.331	5.118	5.134	0.512
◆712001→	320	N	1.181 30	1.811 46	1.820 46.23	0.315 8	712113→	TFW-H	T	2.362	2.953	2.972	0.394
712003←	320	V	4.724	5.512	5.524	0.512	712114←	TFW-H	T	5.118	5.906	5.921	0.512
712004←	320	V	4.134	5.118	5.128	0.472	712115→	TFW-H	T	3.150	3.937	3.953	0.512
◆712005→	320	H	2.559 65	3.307 84	3.318 84.28	0.354 9	712116→	TFW-H	T	3.500	4.331	4.346	0.472
◆712006←	320	H	2.362 60	3.228 82	3.239 82.27	0.472 12	712118←	TFW-H	T	6.299	7.480	7.496	0.512
◆712007	480	V	0.984 25	1.378 35	1.388 35.25	0.276 7	712119→	TFW-H	T	3.736	4.724	4.740	0.512
◆712008←	320	H	1.102 28	1.654 42	1.663 42.24	0.315 8	712120→	TFW-H	T	3.150	3.937	3.953	0.512
712009	320	V	1.063	1.575	1.583	0.315	712122←	TFW-H	T	6.142	7.087	7.102	0.591
◆712010→	320	H	1.890 48	2.756 70	2.767 70.28	0.354 9	712123→	TFW-H	T	3.150	3.937	3.953	0.512
◆712011	320	S	1.575 40	2.953 75	2.961 75.20	0.472 12	712124→	TFW-H	T	3.543	4.331	4.346	0.472
712012	#	V	0.984	1.752	1.756	0.313	712125→	TFW-H	T	2.126	2.874	2.890	0.502
712013	#	S	1.000	1.752	1.756	0.313	712126←	TFW-H	T	3.110	3.898	3.913	0.378
712014	#	S	0.750	1.250	1.254	0.375	712146	250	S	1.688	2.551	2.562	0.470
712015	#	V	0.875	1.375	1.379	0.250	712250	470	V	2.250	3.000	3.005	0.375
712016	#	S	1.000	1.499	1.503	0.250	712260	470	S	1.750	2.810	2.814	0.315
							712270	480	S	0.875	1.436	1.441	0.256
							712375	900	N	2.375	4.064	4.069	1.092
							712449←	320	V	4.812	5.543	5.551	0.472
							712511→	320	V	2.677	3.504	3.512	0.433
							712512←	#	N	2.250	3.252	3.260	0.551
							712516→	#	N	1.875	2.677	2.689	0.551
							◆712551	320	S	1.575 40	2.205 56	2.216 56.29	0.315 8
							712598	470	S	2.598	3.999	4.004	0.780

Part Number	Style	Matl	Shaft	Bore	O.D.	Width	Part Number	Style	Matl	Shaft	Bore	O.D.	Width
712598S	470	S	2.598	3.999	4.004	0.780	◆759008XX	320	S	2.953	3.543	3.551	0.315
712625	900	N	2.625	4.064	4.069	0.960				75	90	90.20	8
712750	410	V	3.500	4.501	4.506	0.468							
712937	900	N	2.937	4.939	4.944	1.250	◆759010XX	320	S	2.953	3.543	3.553	0.394
713103→	690	V	2.180	3.190	3.194	0.620				75	90	90.25	10
◆713655	320	N	1.378	2.047	2.061	0.315	◆759510XX	350	S	2.953	3.74	3.751	0.394
			35	52	52.35	8				75	95	95.28	10
713750	690	V	3.750	4.500	4.506	0.468	◆10X012010XX	350	S	3.937	4.724	4.736	0.394
◆713771→	350	V	1.378	1.969	1.982	0.315				100	120	120.30	10
			35	50	50.34	8	◆10X012012XX	350	S	3.937	4.724	4.735	0.472
										100	120	120.28	12
							◆10X012512XX	350	S	3.937	4.921	4.932	0.472
										100	125	125.28	12
714075	#	H	1.771	2.500	2.504	0.359	◆10X013012XX	350	S	3.937	5.118	5.129	0.472
◆714436	320	S	1.378	1.890	1.899	0.315				100	130	130.28	12
			35	48	48.24	8	◆10X213013XX	350	S	4.016	5.118	5.129	0.512
714470	480	V	3.125	4.003	4.008	0.500				102	130	130.28	13
714503↔	320	N	1.886	2.750	2.761	0.469	◆10X512513XX	320	S	4.134	4.921	4.932	0.512
714512	870	N	2.375	4.498	4.504	0.391				105	125	125.28	13
							◆10X513012XX	350	S	4.134	5.118	5.129	0.472
										105	130	130.28	12
714569	#	V	1.574	2.410	2.415	0.540	◆10X514012XX	350	S	4.134	5.512	5.523	0.472
714616	#	V	0.630	1.762	1.770	0.354				105	140	140.28	12
◆714619	350	S	1.181	1.890	1.899	0.315				105	140	140.28	12
			30	48	48.24	8							
714654	470	N	2.000	2.995	3.002	0.500	◆11X013012XX	350	S	4.331	5.118	5.129	0.472
714655	480	N	1.375	1.981	1.989	0.252				110	130	130.28	12
							◆11X013513XX	320	S	4.331	5.315	5.327	0.512
										110	135	135.30	13
714662	470	V	0.630	1.072	1.076	0.354	◆11X014012XX	320	S	4.331	5.512	5.523	0.472
714670	470	N	2.500	3.500	3.504	0.450				110	140	140.28	12
714675	#	V	1.842	2.748	2.751	0.425	◆11X014013XX	450	S	4.331	5.512	5.521	0.512
714713↔	960	V	4.000	4.999	5.004	0.469				110	140	140.23	13
714750	480	V	4.750	5.751	5.756	0.500	◆11X014513XX	350	S	4.331	5.709	5.72	0.512
										110	145	145.30	13
714810←	#	V	3.003	3.751	3.761	0.570	◆11X015015XX	350	S	4.331	5.906	5.917	0.591
715100	#	S	1.875	3.150	3.155	0.250				110	150	150.28	15
715101	#	S	1.370	1.375	2.438	0.250	◆11X2140013XX	350	S	4.409	5.512	5.524	0.512
715319	470	N	3.500	5.126	5.131	0.625				112	140	140.32	13
◆716102←	320	H	3.346	4.134	4.145	0.394	◆11X414013XX	350	S	4.488	5.512	5.523	0.512
			85	105	105.28	10				114	140	140.28	13
							◆11X514012XX	350	S	4.528	5.512	5.523	0.472
◆716445	350	V	2.953	3.740	3.751	0.394				115	140	140.28	12
			75	95	95.28	10	◆11X514513XX	350	S	4.528	5.709	5.72	0.512
716484	320	V	1.890	2.559	2.571	0.394				115	145	145.30	13
◆717004	480	S	4.724	5.512	5.520	0.472							
			120	140	140.21	12	◆11X514514XX	320	S	4.528	5.709	5.717	0.551
◆717005←	320	S	3.740	4.331	4.342	0.433				115	145	145.20	14
			95	110	110.29	11	◆11X515012XX	350	S	4.528	5.906	5.917	0.472
717006	450	S	3.740	4.528	4.537	0.394				115	150	150.28	12
							◆12X014013XX	350	S	4.724	5.512	5.523	0.512
										120	140	140.28	13
718610	470	N	0.562	1.004	1.008	0.254	◆12X014512XX	350	S	4.724	5.709	5.72	0.472
719316	720	V	1.875	3.160	3.165	0.720				120	145	145.28	12
722108	VS1	N	1.313	1.625	-	0.156	◆12X015012XX	350	S	4.724	5.906	5.917	0.472
722109	VS1	S	2.250	2.675	2.720	0.539				120	150	150.28	12
722250	900	N	2.250	4.064	4.069	1.092				120	150	150.28	12
							◆12X016012XX	350	S	4.724	6.299	6.31	0.472
722250S	900	N	2.250	4.064	4.069	1.092				120	160	160.28	12
727410	440	S	0.750	1.000	1.006	0.126	◆12X25045XX	320	S	0.472	0.984	0.992	0.177
◆729010XX	350	S	2.835	3.543	3.551	0.394				12	25	25.20	4.50
			72	90	90.20	10	◆12X515012XX	320	S	4.921	5.906	5.917	0.472
◆729510XX	350	S	2.835	3.74	3.751	0.394				125	150	150.28	12
			72	95	95.28	10	◆12X515512XX	320	S	4.921	6.102	6.11	0.472
										125	155	155.20	12

Part Number	Style	Matl	Shaft	Bore	O.D.	Width	Part Number	Style	Matl	Shaft	Bore	O.D.	Width
◆12X516012XX	350	S	4.921 125	6.299 160	6.31 160.28	0.472 12	◆16X020012XX	320	S	6.299 160	7.874 200	7.882 200.20	0.472 12
◆12X517015XX	320	S	4.921 125	6.693 170	6.701 170.20	0.591 15	◆16X020015XX	320	S	6.299 160	7.874 200	7.882 200.20	0.591 15
◆12X815015XX	350	S	5.039 128	5.906 150	5.917 150.28	0.591 15	◆17X020015XX	350	S	6.693 170	7.874 200	7.888 200.35	0.591 15
◆13X015010XX	470	S	5.118 130	5.906 150	5.909 150.10	0.394 10	◆17X021015XX	320	S	6.693 170	8.268 210	8.276 210.20	0.591 15
◆13X016012XX	350	S	5.118 130	6.299 160	6.31 160.28	0.472 12	◆17X520015XX	320	S	6.89 175	7.874 200	7.888 200.35	0.591 15
◆13X016015XX	320	S	5.118 130	6.299 160	6.307 160.20	0.591 15	◆18X021015XX	350	S	7.087 180	8.268 210	8.281 210.35	0.591 15
◆13X017012XX	350	S	5.118 130	6.693 170	6.705 170.30	0.472 12	◆18X512013XX	350	S	7.283 185	8.268 210	8.281 210.35	0.512 13
◆13X017015XX	350	S	5.118 130	6.693 170	6.704 170.28	0.591 15	◆19X022016XX	350	S	7.48 190	8.661 220	8.675 220.35	0.63 16
◆13X516013XX	350	S	5.315 135	6.299 160	6.314 160.38	0.512 13	◆19X023016XX	320	S	7.48 190	8.858 230	8.866 230.20	0.63 16
◆13X517012XX	350	S	6.513 135	6.693 170	6.708 170.38	0.472 12	◆20X023015XX	450	S	7.874 200	9.055 230	9.069 230.35	0.591 15
◆13X815212XX	470	S	5.433 138	5.984 152	5.988 152.10	0.472 12	◆21X024015XX	350	S	8.268 210	9.449 240	9.463 240.35	0.591 15
◆14X016012XX	320	S	5.512 140	6.299 160	6.307 160.20	0.472 12	◆21X025015XX	320	S	8.268 210	9.843 250	9.85 250.20	0.591 15
◆14X016013XX	350	S	5.512 140	6.299 160	6.31 160.27	0.512 13	◆22X025015XX	350	S	8.661 220	9.843 250	9.856 250.35	0.591 15
◆14X017012XX	320	S	5.512 140	6.693 170	6.705 170.30	0.472 12	◆23X026015XX	350	S	9.055 230	10.236 260	10.25 260.35	0.591 15
◆14X017015XX	350	S	5.512 140	6.693 170	6.71 170.43	0.591 15	◆24X027015XX	350	S	9.449 240	10.63 270	10.644 270.35	0.591 15
◆14X018012XX	350	S	5.512 140	7.087 180	7.098 180.30	0.472 12	◆24X028016XX	320	S	9.449 240	11.024 280	11.031 280.20	0.63 16
◆14X018018XX	320	S	5.512 140	7.087 180	7.102 180.38	0.709 18	◆28X032020XX	320	S	11.024 280	12.598 320	12.616 320.45	0.787 20
◆14X416012XX	350	S	5.669 144	6.299 160	6.309 160.25	0.472 12	◆30X034020XX	320	S	11.811 300	13.386 340	13.404 340.45	0.787 20
◆14X516414XX	470	S	5.709 145	6.457 164	6.461 164.10	0.551 14	◆38X52085XX	320	S	1.496 38	2.047 52	2.057 52.25	0.335 8.50
◆14X517012XX	350	S	5.709 145	6.693 170	6.711 170.45	0.472 12	◆55X10013X	450	S	2.165 55	3.937 100	3.949 100.30	0.5 12.70
◆14X517515XX	350	S	5.709 145	6.89 175	6.905 175.38	0.591 15	◆55X1007X	320	S	2.165 55	2.953 75	2.961 75.20	0.276 7
◆14X518012XX	350	S	5.709 145	7.087 180	7.098 180.28	0.472 12	◆56X72115XX	350	S	2.205 56	2.835 72	2.85 72.40	0.453 11.50
◆14X518012XX	350	S	5.709 145	7.087 180	7.098 180.28	0.472 12	◆60X10010XX↔	320	N	2.362 60	3.937 100	3.945 100.20	0.394 10
◆14X817015XX	350	S	5.709 148	6.89 170	6.905 170.28	0.591 15	◆60X11008XX	320	S	2.362 60	4.331 110	4.339 110.20	0.315 8
◆14X817015XX	350	S	5.827 148	6.693 170	6.704 170.28	0.591 15	◆62X10007XX	320	S	2.441 62	3.937 100	3.949 100.30	0.276 7
◆15X018012XX	350	S	5.906 150	7.087 180	7.1 180.35	0.472 12	◆65X10007XX	320	S	2.559 65	3.937 100	3.949 100.30	0.276 7
◆15X018015XX	350	S	5.906 150	7.087 180	7.1 180.35	0.591 15	◆65X10010XX	350	S	2.559 65	3.937 100	3.948 100.28	0.394 10
◆15X518015XX	320	S	6.102 155	7.087 180	7.096 180.23	0.591 15	◆68X10010XX	350	S	2.677 68	3.937 100	3.945 100.20	0.394 10
◆16X018510XX	350	S	6.299 160	7.283 185	7.297 185.35	0.394 10	◆68X10013XX	350	S	2.677 68	3.937 100	3.948 100.28	0.512 13
◆16X019015XX	350	S	6.299 160	7.48 190	7.494 190.35	0.591 15	◆70X10010XX	320	S	2.756 70	3.937 100	3.945 100.20	0.394 10

Part Number	Style	Matl	Shaft	Bore	O.D.	Width	Part Number	Style	Matl	Shaft	Bore	O.D.	Width
◆70X10013XX	350	S	2.756 70	3.937 100	3.948 100.28	0.512 13	◆85X13013XX	480	S	3.346 85	5.118 130	5.124 130.15	0.5 12.70
◆70X10507XX	320	S	2.756 70	4.134 105	4.146 105.30	0.276 7	◆88X11012XX	350	S	3.465 88	4.331 110	4.342 110.28	0.472 12
◆70X10513XX	350	S	2.756 70	4.134 105	4.142 105.20	0.512 13	◆90X11012XX	350	S	3.543 90	4.331 110	4.339 110.20	0.472 12
◆70X11010XX	350	S	2.756 70	4.331 110	4.339 110.20	0.394 10	◆90X11512XX	320	S	3.543 90	4.528 115	4.535 115.20	0.472 12
◆72X10010XX	350	S	2.835 72	3.937 100	3.945 100.20	0.394 10	◆90X12012XX	320	S	3.543 90	4.724 120	4.735 120.28	0.472 12
◆72X10012XX↔	320	S	2.835 72	3.937 100	3.949 100.31	0.472 12	◆90X12507XX	320	S	3.543 90	4.921 125	4.949 125.70	0.276 7
◆75X10010XX	320	S	2.953 75	3.937 100	3.945 100.20	0.394 10	◆90X12513XX	320	S	3.543 90	4.921 125	4.933 125.30	0.512 13
◆75X10012XX	320	S	2.953 75	3.937 100	3.948 100.27	0.472 12	◆90X14514XX	320	S	3.543 90	5.709 145	5.717 145.20	0.551 14
◆75X10513XX	320	S	2.953 75	4.134 105	4.144 105.27	0.512 13	◆92X12013XX	350	S	3.622 92	4.724 120	4.734 120.24	0.512 13
◆75X11012XX	320	S	2.953 75	4.331 110	4.339 110.20	0.472 12	◆95X11010XX	320	S	3.74 95	4.331 110	4.339 110.20	0.394 10
◆75X11512XX	350	S	2.953 75	4.528 115	4.539 115.30	0.472 12	◆95X11512XX	350	S	3.74 95	4.528 115	4.539 115.28	0.472 12
◆75X12010XX	320	S	2.953 75	4.724 120	4.732 120.20	0.394 10	◆95X12012XX	350	S	3.74 95	4.724 120	4.735 120.28	0.472 12
◆78X10010XX	350	S	3.071 78	3.937 100	3.948 100.27	0.394 10	◆95X12512XX	350	S	3.74 95	4.921 125	4.932 125.28	0.472 12
◆78X10510XX	320	S	3.071 78	4.134 105	4.142 105.20	0.394 10	◆95X13012XX	350	S	3.74 95	5.118 130	5.129 130.28	0.472 12
◆78X11510XX	320	S	3.071 78	4.528 115	4.535 115.20	0.394 10	◆98X12013XX	350	S	3.858 98	4.724 120	4.732 120.20	0.512 13
◆80X10010XX	350	S	3.15 80	3.937 100	3.945 100.20	0.394 10							
◆80X10510XX	320	S	3.15 80	4.134 105	4.142 105.20	0.394 10							
◆80X10513XX	480	S	3.15 80	4.134 105	4.144 105.27	0.512 13							
◆80X11010XX	320	S	3.15 80	4.331 110	4.342 110.28	0.394 10							
◆80X11012XX	350	S	3.15 80	4.331 110	4.342 110.28	0.472 12							
◆80X12010XX	320	S	3.15 80	4.724 120	4.732 120.20	0.394 10							
◆80X12013XX	320	S	3.15 80	4.724 120	4.735 120.28	0.512 13							
◆82X10513XX	250	S	3.228 82	4.134 105	4.144 105.25	0.512 13							
◆85X10510XX	320	S	3.346 85	4.134 105	4.145 105.28	0.394 10							
◆85X10513XX	320	S	3.346 85	4.134 105	4.145 105.28	0.512 13							
◆85X11010XX	350	S	3.346 85	4.331 110	4.339 110.20	0.394 10							
◆85X11012XX	350	S	3.346 85	4.331 110	4.342 110.28	0.472 12							
◆85X11513XX	350	S	3.346 85	4.528 115	4.528 115.00	0.512 13							
◆85X12012XX	320	S	3.346 85	4.724 120	4.735 120.28	0.472 12							
◆85X12512XX	320	S	3.346 85	4.921 125	4.929 125.20	0.472 12							

Part Number	Style	Matl	Shaft	Bore	O.D.	Width	Part Number	Style	Matl	Shaft	Bore	O.D.	Width
61607XX	350	S	6	16	16.28	7	152807XX	320	S	15	28	28.20	7
62207XX	350	S	6	22	22.28	7	153007XX	350	S	15	30	30.23	7
71607XX	320	S	7	16	16.28	7	153207XX	350	S	15	32	32.20	7
72207XX	350	S	7	22	22.28	7	*153207XX	350	V	15	32	32.20	7
81404XX	350	S	8	14	14.20	4	153208XX	350	S	15	32	32.22	8
81607XX	350	S	8	16	16.23	7	153507XX	350	S	15	35	35.23	7
81805XX	350	S	8	18	18.20	5	153706XX	320	S	15	37	37.20	6
81807XX	320	S	8	18	18.20	7	154007XX	320	S	15	40	40.20	7
82207XX	320	S	8	22	22.28	7	162204XX	320	S	16	22	22.20	4
*82207XX	320	V	8	22	22.20	7	162406XX	320	S	16	24	24.20	6
82407XX	350	S	8	24	24.28	7	162407XX	320	S	16	24	24.20	7
91807XX	350	S	9	18	18.20	7	162405XX	350	S	16	25	25.20	5
92207XX	350	S	9	22	22.20	7	162607XX	320	S	16	26	26.20	7
92407XX	350	S	9	24	24.28	7	162807XX	350	S	16	28	28.23	7
92607XX	350	S	9	26	26.28	7	*162807XX	320	V	16	28	28.20	7
101907XX	350	S	10	19	19.20	7	163007XX	350	S	16	30	30.23	7
102207XX	320	S	10	22	22.28	7	163207XX	320	S	16	32	32.28	7
102407XX	350	S	10	24	24.23	7	163507XX	350	S	16	35	35.23	7
102507XX	320	S	10	25	25.28	7	163807XX	320	S	16	38	38.20	7
102607XX	320	S	10	26	26.23	7	164007XX	320	S	16	40	40.20	7
111704XX	320	S	11	17	17.25	4	172707XX	320	S	17	27	27.20	7
112207XX	350	S	11	22	22.28	7	172807XX	350	S	17	28	28.23	7
112607XX	350	S	11	26	26.28	7	173007XX	350	S	17	30	30.23	7
121905XX	320	S	12	19	19.20	5	173207XX	350	S	17	32	32.22	7
122005XX	320	S	12	20	20.28	5	173507XX	350	S	17	35	35.18	7
122207XX	350	S	12	22	22.25	7	173508XX	350	S	17	35	35.20	8
122407XX	320	S	12	24	24.23	7	173707XX	320	S	17	37	37.20	7
12X25045XX	320	S	12	25	25.20	4.50	173807XX	320	S	17	38	38.20	7
122507XX	480	S	12	25	25.25	7	174007XX	350	S	17	40	40.23	7
122607XX	320	S	12	26	26.20	7	174707XX	350	S	17	47	47.20	7
122807XX	350	S	12	28	28.20	7	174708XX	320	S	17	47	47.20	8
123007XX	350	S	12	30	30.20	7	182806XX	350	S	18	28	28.28	6
123207XX	350	S	12	32	32.20	7	183007XX	350	S	18	30	30.23	7
123507XX	320	S	12	35	35.20	7	183207XX	350	S	18	32	32.20	7
132206XX	320	S	13	22	22.20	6	183208XX	350	S	18	32	32.22	8
132607XX	320	S	13	26	26.20	7	183507XX	320	S	18	35	35.18	7
132807XX	320	S	13	28	28.20	7	183708XX	320	S	18	37	37.20	8
133007XX	320	S	13	30	30.20	7	183807XX	320	S	18	38	38.20	7
142407XX	350	S	14	24	24.23	7	184007XX	350	S	18	40	40.22	7
142505XX	320	S	14	25	25.23	5	192706XX	350	S	19	27	27.20	6
142607XX	320	S	14	26	26.23	7	193007XX	320	S	19	30	30.20	7
142707XX	320	S	14	27	27.20	7	193207XX	350	S	19	32	32.20	7
142806XX	350	S	14	28	28.23	6	193208XX	320	S	19	32	32.20	8
143007XX	320	S	14	30	30.20	7	193510XX	350	S	19	35	35.23	10
143207XX	320	S	14	32	32.20	7	194010XX	350	S	19	40	40.23	10
143507XX	350	S	14	35	35.22	7	194707XX	320	S	19	47	47.20	7
152407XX	350	S	15	24	24.23	7	202806XX	320	S	20	28	28.20	6
152505XX	320	S	15	25	25.20	5	203007XX	350	S	20	30	30.28	7
152507XX	350	S	15	25	25.20	7	203207XX	350	S	20	32	32.23	7
152607XX	350	S	15	26	26.23	7	203507XX	350	S	20	35	35.23	7

Part Number	Style	Matl	Shaft	Bore	O.D.	Width	Part Number	Style	Matl	Shaft	Bore	O.D.	Width
203607XX	320	S	20	36	36.20	7	256210XX	320	S	25	62	62.28	10
203707XX	320	S	20	37	37.20	7	263707XX	320	S	26	37	37.20	7
203708XX	320	S	20	37	37.20	8	263805XX	320	S	26	38	38.20	5
203807XX	320	S	20	38	38.20	7	264007XX	320	S	26	40	40.20	7
204007XX	350	S	20	40	40.23	7	264207XX	320	S	26	42	42.20	7
204010XX	350	S	20	40	40.23	10	264210XX	350	S	26	42	42.23	10
204207XX	350	S	20	42	42.25	7	264707XX	350	S	26	47	47.23	7
204210XX	320	S	20	42	42.15	10	264807XX	320	S	26	48	48.23	7
204707XX	350	S	20	47	47.22	7	265208XX	320	S	26	52	52.20	8
205207XX	350	S	20	52	52.20	7	273707XX	350	S	27	37	37.15	7
213507XX	320	S	21	35	35.20	7	274210XX	350	S	27	42	42.23	10
213508XX	320	S	21	35	35.20	8	274308XX	320	S	27	43	43.20	8
223207XX	350	S	22	32	32.23	7	274508XX	350	S	27	45	45.25	8
223507XX	350	S	22	35	35.23	7	274710XX	350	S	27	47	47.23	10
223607XX	320	S	22	36	36.20	7	275208XX	350	S	27	52	52.20	8
223707XX	350	S	22	37	37.23	7	283807XX	350	S	28	38	38.23	7
223807XX	350	S	22	38	38.20	7	284007XX	350	S	28	40	40.26	7
223808XX	320	S	22	38	38.20	8	284008XX	320	S	28	40	40.20	8
224007XX	350	S	22	40	40.23	7	284208XX	350	S	28	42	42.23	8
224008XX	350	S	22	40	40.20	8	284406XX	320	N	28	44	44.23	6
224207XX	320	S	22	42	42.20	7	284508XX	320	S	28	45	45.20	8
224210XX	350	S	22	42	42.20	10	284707XX	350	S	28	47	47.22	7
224507XX	350	S	22	45	45.23	7	284808XX	320	S	28	48	48.20	8
224707XX	350	S	22	47	47.23	7	285207XX	350	S	28	52	52.23	7
243507XX	350	S	24	35	35.23	7	304007XX	350	S	30	40	40.23	7
243707XX	350	S	24	37	37.23	7	304207XX	350	S	30	42	42.20	7
243807XX	320	S	24	38	38.20	7	304407XX	250	S	30	44	44.28	7
244007XX	350	S	24	40	40.23	7	304505XX	320	S	30	45	45.22	5
244207XX	320	S	24	42	42.20	7	304508XX	320	S	30	45	45.20	8
244210XX	320	S	24	42	42.25	10	304607XX	320	S	30	46	46.20	7
244707XX	350	S	24	47	47.23	7	304707XX	350	S	30	47	47.25	7
245207XX	320	S	24	52	52.20	7	304808XX	350	S	30	48	48.28	8
253506XX	320	S	25	35	35.20	6	305007XX	350	S	30	50	50.23	7
253506XX	350	S	25	35	35.25	7	305008XX	480	S	30	50	50.20	8
253607XX	320	S	25	36	36.23	7	305207XX	350	S	30	52	52.23	7
253608XX	350	S	25	36	36.22	8	305510XX	350	S	30	55	55.28	10
253707XX	320	S	25	37	37.20	7	305608XX	350	S	30	56	56.20	8
253807XX	350	S	25	38	38.23	7	306207XX	350	S	30	62	62.28	7
254007XX	350	S	25	40	40.22	7	307210XX	350	S	30	72	72.27	10
254206XX	350	S	25	42	42.20	6	314408XX	320	S	31	44	44.20	8
254208XX	320	S	25	42	42.20	8	324207XX	350	S	32	42	42.20	7
254210XX	350	S	25	42	42.28	10	324208XX	320	S	32	42	42.20	8
254508XX	350	S	25	45	45.23	8	324307XX	320	S	32	43	43.20	7
254607XX	320	S	25	46	46.20	7	324507XX	320	S	32	45	45.23	7
254707XX	350	S	25	47	47.23	7	324606XX	320	S	32	46	46.23	6
254808XX	320	S	25	48	48.20	8	324707XX	350	S	32	47	47.23	7
255010XX	350	S	25	50	50.28	10	324808XX	350	S	32	48	48.20	8
255207XX	350	S	25	52	52.27	7	325008XX	350	S	32	50	50.23	8
255208XX	350	S	25	52	52.20	8	325207XX	350	S	32	52	52.28	7
255210XX	350	S	25	52	52.20	10	325410XX	320	S	32	54	54.23	10

Part Number	Style	Matl	Shaft	Bore	O.D.	Width	Part Number	Style	Matl	Shaft	Bore	O.D.	Width
325610XX	350	S	32	56	56.28	10	385407XX	480	S	38	54	54.18	7
325808XX	320	S	32	58	58.20	8	385410XX	320	S	38	54	54.18	10
326008XX	320	S	32	60	60.20	8	385507XX	350	N	38	55	55.23	7
326010XX	480	S	32	60	60.20	10	385610XX	350	S	38	56	56.28	10
326208XX	320	S	32	62	62.20	8	385808XX	470	S	38	58	58.11	8
327208XX	320	S	32	72	72.20	8	386008XX	320	S	38	60	60.20	8
335012XX	320	S	33	50	50.25	12	386010XX	350	S	38	60	60.35	10
335206XX	320	S	33	52	52.25	6	386207XX	350	S	38	62	62.28	7
344508XX	320	S	34	45	45.20	8	386508XX	320	S	38	65	65.20	8
345208XX	320	S	34	52	52.28	8	386808XX	320	S	38	68	68.20	8
345409XX	350	S	34	54	54.20	9	386810XX	320	S	38	68	68.20	10
345509XX	320	S	34	55	55.20	9	387010XX	350	S	38	70	70.20	10
346210XX	350	S	34	62	62.18	10	387210XX	350	S	38	72	72.20	10
354507XX	350	S	35	45	45.15	7	387408XX	320	S	38	74	74.20	8
354707XX	350	S	35	47	47.23	7	387411XX	320	N	38	74	74.20	11
354808XX	320	S	35	48	48.20	8	405008XX	350	S	40	50	50.20	8
355007XX	350	S	35	50	50.20	7	405207XX	350	S	40	52	52.25	7
355008XX	350	S	35	50	50.24	8	405406XX	470	S	40	54	54.20	5.50
355207XX	350	S	35	52	52.20	7	405506XX	350	S	40	55	55.20	6.50
355208XX	330	S	35	52	52.13	8	405508XX	350	S	40	55	55.28	8
355408XX	350	S	35	54	54.20	8	405607XX	320	S	40	56	56.20	7
355508XX	470	S	35	55	55.10	8	405710XX	320	S	40	57	57.20	10
355511XX	320	S	35	55	55.23	11	405808XX	350	S	40	58	58.20	8
355608XX	350	S	35	56	56.20	8	405810XX	320	S	40	58	58.28	10
355610XX	320	S	35	56	56.27	10	406010XX	350	S	40	60	60.20	10
355810XX	350	S	35	58	58.28	10	406207XX	350	S	40	62	62.20	7
356010XX	350	S	35	60	60.23	10	406208XX	320	S	40	62	62.25	8
356207XX	350	S	35	62	62.28	7	406212XX	350	S	40	62	62.25	11.50
356210XX	350	S	35	62	62.20	10	406510XX	350	S	40	65	65.28	10
356408XX	470	N	35	64	64.13	8	406808XX	350	S	40	68	68.80	8
356508XX	320	S	35	65	65.20	8	406812XX	350	S	40	68	68.25	12
356510XX	320	S	35	65	65.20	10	407008XX	320	S	40	70	70.20	8
357008XX	320	S	35	70	70.20	8	407207XX	350	S	40	72	72.35	7
357210XX	350	S	35	72	72.28	10	407808XX	320	S	40	78	78.80	8
358008XX	320	S	35	80	80.20	8	407810XX	350	S	40	78	78.20	10
364707XX	350	S	36	47	47.20	7	408010XX	350	S	40	80	80.28	10
365007XX	470	S	36	50	50.08	7	409008XX	350	S	40	90	90.20	8
365207XX	350	S	36	52	52.20	7	415507XX	320	S	41	55	55.29	7
365408XX	350	S	36	54	54.20	8	415607XX	350	S	41	56	56.25	7
365610XX	350	S	36	56	56.25	10	425507XX	320	S	42	55	55.20	7
365808XX	470	S	36	58	58.25	8	425508XX	350	S	42	55	55.28	8
365812XX	350	S	36	58	58.23	12	425607XX	320	S	42	56	56.13	7
366007XX	320	S	36	60	60.20	7	425807XX	480	S	42	58	58.10	7
366207XX	320	S	36	62	62.28	7	426007XX	320	S	42	60	60.22	7
366810XX	350	S	36	68	68.28	10	426208XX	350	S	42	62	62.27	8
375208XX	350	S	37	52	52.28	8	426510XX	470	N	42	65	65.15	10
385007XX	350	S	38	50	50.25	7	426808XX	320	S	42	68	68.20	8
385207XX	320	S	38	52	52.20	7	426810XX	320	S	42	68	62.20	10
38X52085XX	320	S	38	52	52.25	8.50	427010XX	320	S	42	70	70.20	10
385308XX	320	S	38	53	53.20	8	427208XX	320	S	42	72	72.20	8

Part Number	Style	Matl	Shaft	Bore	O.D.	Width	Part Number	Style	Matl	Shaft	Bore	O.D.	Width
427210XX	320	S	42	72	72.27	10	507512XX	320	S	50	75	75.28	12
428008XX	320	S	42	80	80.20	8	508008XX	350	S	50	80	80.28	8
428010XX	350	S	42	80	80.20	10	508508XX	320	S	50	85	85.20	8
435508XX	320	S	43	55	55.20	8	509008XX	320	S	50	90	90.20	8
436508XX	320	S	43	65	65.20	8	509010XX	350	S	50	90	90.28	10
446007XX	320	S	44	60	60.20	7	516507XX	470	S	51	65	65.10	7
446010XX	350	S	44	60	60.20	10	526509XX	350	S	52	65	65.30	9
446208XX↔	320	S	44	62	62.26	8	526808XX	350	S	52	68	68.28	8
446510XX	350	S	44	65	65.28	10	526910XX	350	S	52	69	69.28	10
447008XX	320	S	44	70	70.20	8	527008XX	320	S	52	70	70.20	8
447210XX	350	S	44	72	72.11	10	527208XX	350	S	52	72	72.20	8
455807XX	350	S	45	58	58.28	7	527512XX	350	S	52	75	75.28	12
456007XX	350	S	45	60	60.20	7	528010XX↔	320	S	52	80	80.28	10
456008XX	350	S	45	60	60.20	8	528208XX	320	S	52	82	82.20	8
456010XX	350	S	45	60	60.25	10	528507XX	320	S	52	85	85.20	8
456208XX	350	S	45	62	62.30	8	546508XX	320	S	54	65	65.20	8
456508XX	350	S	45	65	65.28	8	547210XX	320	S	54	72	72.25	10
456807XX	320	S	45	68	68.28	7	547308XX	320	S	54	73	73.20	8
457010XX	320	S	45	70	70.18	10	548210XX	320	S	54	82	82.35	10
457207XX	350	S	45	72	72.28	7	548510XX	320	S	54	85	85.28	10
457210XX	350	S	45	72	72.20	10	556808XX	320	S	55	68	68.28	8
457295XX	320	S	45	72	72.25	10	557008XX	350	S	55	70	70.27	8
457212XX	350	S	45	72	72.28	12	557208XX	350	S	55	72	72.25	8
457507XX	320	S	45	75	75.20	7	55X1007X	320	S	55	75	75.20	7
458010XX	350	S	45	80	80.28	10	557508XX	350	S	55	75	75.20	8
458510XX	350	S	45	85	85.20	10	557510XX	350	S	55	75	75.35	10
458513XX	450	S	45	85	85.25	13	557810XX	350	S	55	78	78.28	10
467008XX	320	S	46	70	70.20	8	558008XX	350	S	55	80	80.28	8
466507XX	320	S	46	65.00	65.20	7	558212XX	350	S	55	82	82.30	12
476208XX	320	S	47	62	62.20	8	558510XX	350	S	55	85	85.31	10
476508XX	320	S	47	65	65.20	8	558808XX↔	320	S	55	88	88.20	8
476810XX	320	S	47	68	68.27	10	559013XX	350	S	55	90	90.28	13
477010XX	320	S	47	70	70.20	10	55X10013X	450	S	55	100	100.30	13
486208XX	350	S	48	62	62.10	8	566810XX	480	N	56	68	68.12	10
486309XX	470	S	48	63	63.09	9	567008XX	350	S	56	70	70.20	8
486510XX	320	S	48	65	65.30	10	567207XX	320	S	56	72	72.20	7
486810XX	320	N	48	68	68.27	10	56X72115XX	350	S	56	72	72.40	11.50
487008XX	350	S	48	70	70.20	8	567507XX	320	S	56	75	75.20	7
487009XX	350	S	48	70	70.28	9	568008XX	320	S	56	80	80.28	8
487207XX	320	S	48	72	72.31	7	568208XX	320	S	56	82	82.20	8
487510XX	320	S	48	75	75.20	10	568508XX	350	S	56	85	85.28	8
488008XX	320	S	48	80	80.20	8	568808XX	320	S	56	88	88.20	8
489010XX	350	S	48	90	90.20	10	569008XX	320	S	56	90	90.20	8
506207XX	350	S	50	62	62.28	7	578513XX	320	S	57	85	85.20	13
506508XX	320	S	50	65	65.28	8	587208XX	350	S	58	72	72.28	8
506808XX	350	S	50	68	68.28	8	587511XX	350	S	58	75	75.28	11
507008XX	320	S	50	70	70.20	8	588008XX	350	S	58	80	80.28	8
507009XX	320	S	50	70	70.20	9	588513XX	320	S	58	85	85.25	13
507208XX	350	S	50	72	72.28	8	588808XX	320	S	58	88	88.20	8
507507XX	320	S	50	75	75.20	7	589010XX	350	S	58	90	90.28	10

Part Number	Style	Matl	Shaft	Bore	O.D.	Width	Part Number	Style	Matl	Shaft	Bore	O.D.	Width
607208XX	350	S	60	72	72.28	8	729010XX	350	S	72	90	90.20	10
607508XX	350	S	60	75	75.28	8	729510XX	350	S	72	95	95.28	10
608008XX	350	S	60	80	80.20	8	72X10010XX	350	S	72	100	100.20	10
608207XX	320	S	60	82	82.20	7	72X10012XX↔	320	S	72	100	100.31	12
608212XX	350	S	60	82	82.30	12	759008XX	320	S	75	90	90.20	8
608508XX	350	S	60	85	85.28	8	759010XX	320	S	75	90	90.25	10
608512XX	320	S	60	85	85.20	12	759510XX	350	S	75	95	95.28	10
609008XX	320	S	60	90	90.25	8	75X10010XX	320	S	75	100	100.20	10
609010XX	350	S	60	90	90.27	10	75X10012XX	320	S	75	100	100.27	12
609508XX	320	S	60	95	95.20	8	75X10513XX	320	S	75	105	105.27	13
60X10010XX↔	320	N	60	100	100.20	10	75X11012XX	320	S	75	110	110.20	12
60X11008XX	320	S	60	110	110.20	8	75X11512XX	350	S	75	115	115.30	12
628009XX	320	S	62	80	80.20	9	75X12010XX	320	S	75	120	120.20	10
628010XX	350	S	62	80	80.28	10	78X10010XX	350	S	78	100	100.27	10
628508XX	410	S	62	85	85.13	8	78X10510XX	320	S	78	105	105.20	10
629010XX	350	S	62	90	90.28	10	78X11510XX	320	S	78	115	115.20	10
62X10007XX	320	S	62	100	100.30	7	80X10010XX	350	S	80	100	100.20	10
638510XX	320	S	63	85	85.28	10	80X10510XX	320	S	80	105	105.20	10
639010XX	320	S	63	90	90.14	10	80X10513XX	480	S	80	105	105.27	13
648008XX	320	S	64	80	80.28	8	80X11010XX	320	S	80	110	110.28	10
658008XX	320	S	65	80	80.28	8	80X11012XX	350	S	80	110	110.28	12
658508XX	350	S	65	85	85.20	8	80X12010XX	320	S	80	120	120.20	10
658510XX	350	S	65	85	85.27	10	80X12013XX	320	S	80	120	120.28	13
658808XX	350	S	65	88	88.20	8	80X12013XX	320	S	80	120	120.28	13
658810XX	320	S	65	88	88.20	10	82X10513XX	250	S	82	105	105.25	13
659007XX	320	S	65	90	90.20	7	85X10510XX	320	S	85	105	105.28	10
659010XX	350	S	65	90	90.28	10	85X10513XX	320	S	85	105	105.28	13
659013XX	350	S	65	90	90.20	13	85X11010XX	350	S	85	110	110.20	10
65X10007XX	320	S	65	100	100.30	7	85X11012XX	350	S	85	110	110.28	12
65X10010XX	350	S	65	100	100.28	10	85X11513XX	350	S	85	115	115.00	13
688207XX	350	S	68	82	82.20	7	85X12012XX	320	S	85	120	120.28	12
688508XX	350	S	68	85	85.20	8	85X12512XX	320	S	85	125	125.20	12
689007XX	320	S	68	90	90.20	7	85X13013XX	480	S	85	130	130.15	13
689010XX	350	S	68	90	90.32	10	88X11012XX	350	S	88	110	110.28	12
689510XX	350	S	68	95	95.20	10	90X11012XX	350	S	90	110	110.20	12
68X10010XX	350	S	68	100	100.20	10	90X11512XX	320	S	90	115	115.20	12
68X10013XX	350	S	68	100	100.28	13	90X12012XX	320	S	90	120	120.28	12
708508XX	350	S	70	85	85.28	8	90X12507XX	320	S	90	125	125.70	7
708808XX	480	S	70	88	88.25	8	90X12513XX	320	S	90	125	125.30	13
708812XX	320	S	70	88	88.25	12	90X14514XX	320	S	90	145	145.20	14
709007XX	320	S	70	90	90.20	7	92X12013XX	350	S	92	120	120.24	13
709010XX	350	S	70	90	90.32	10	95X11010XX	320	S	95	110	110.20	10
709212XX	320	S	70	92	92.20	12	95X11512XX	350	S	95	115	115.28	12
709510XX	350	S	70	95	95.28	10	95X12012XX	350	S	95	120	120.28	12
709513XX	350	S	70	95	95.28	13	95X12512XX	350	S	95	125	125.28	12
70X10010XX	320	S	70	100	100.20	10	95X13012XX	350	S	95	130	130.28	12
70X10013XX	350	S	70	100	100.28	13	98X12013XX	350	S	98	120	120.20	13
70X10507XX	320	S	70	105	105.30	7	10X012010XX	350	S	100	120	120.30	10
70X10513XX	350	S	70	105	105.20	13	10X012012XX	350	S	100	120	120.28	12
70X11010XX	350	S	70	110	110.20	10	10X012512XX	350	S	100	125	125.28	12
							10X013012XX	350	S	100	130	130.28	12

Part Number	Style	Matl	Shaft	Bore	O.D.	Width	Part Number	Style	Matl	Shaft	Bore	O.D.	Width
10X213013XX	350	S	102	130	130.28	13	16X018510XX	350	S	160	185	185.35	10
10X512513XX	320	S	105	125	125.28	13	16X019015XX	350	S	160	190	190.35	15
10X513012XX	350	S	105	130	130.28	12	16X020012XX	320	S	160	200	200.20	12
10X514012XX	350	S	105	140	140.28	12	16X020015XX	320	S	160	200	200.20	15
11X013012XX	350	S	110	130	130.28	12	17X020015XX	350	S	170	200	200.35	15
11X013513XX	320	S	110	135	135.30	13	17X021015XX	320	S	170	210	210.20	15
11X014012XX	320	S	110	140	140.28	12	17X520015XX	320	S	175	200	200.35	15
11X014013XX	450	S	110	140	140.23	13	18X021015XX	350	S	180	210	210.35	15
11X014513XX	350	S	110	145	145.30	13	18X512013XX	350	S	185	210	210.35	13
11X015015XX	350	S	110	150	150.28	15	19X022016XX	350	S	190	220	220.35	16
11X2140013XX	350	S	112	140	140.32	13	19X023016XX	320	S	190	230	230.20	16
11X414013XX	350	S	114	140	140.28	13	20X023015XX	450	S	200	230	230.35	15
11X514012XX	350	S	115	140	140.28	12	21X024015XX	350	S	210	240	240.35	15
11X514513XX	350	S	115	145	145.30	13	21X025015XX	320	S	210	250	250.20	15
11X514514XX	320	S	115	145	145.20	14	22X025015XX	350	S	220	250	250.35	15
11X515012XX	350	S	115	150	150.28	12	23X026015XX	350	S	230	260	260.35	15
12X014013XX	350	S	120	140	140.28	13	24X027015XX	350	S	240	270	270.35	15
12X014512XX	350	S	120	145	145.28	12	24X028016XX	320	S	240	280	280.20	16
12X015012XX	350	S	120	150	150.28	12	28X032020XX	320	S	280	320	320.45	20
12X016012XX	350	S	120	160	160.28	12	30X034020XX	320	S	300	340	340.45	20
12X515012XX	320	S	125	150	150.28	12							
12X515512XX	320	S	125	155	155.20	12							
12X516012XX	350	S	125	160	160.28	12							
12X517015XX	320	S	125	170	170.20	15							
*12X815015XX	350	S	128	150	150.28	15							
13X015010XX	470	S	130	150	150.10	10							
13X016012XX	350	S	130	160	160.28	12							
13X016015XX	320	S	130	160	160.20	15							
13X017012XX	350	S	130	170	170.30	12							
13X017015XX	350	S	130	170	170.28	15							
13X516013XX	350	S	135	160	160.38	13							
13X517012XX	350	S	135	170	170.38	12							
13X815212XX	470	S	138	152	152.10	12							
14X016012XX	320	S	140	160	160.20	12							
14X016013XX	350	S	140	160	160.27	13							
14X017012XX	320	S	140	170	170.30	12							
14X017015XX	350	S	140	170	170.43	15							
14X018012XX	350	S	140	180	180.30	12							
14X018018XX	320	S	140	180	180.38	18							
14X416012XX	350	S	144	160	160.25	12							
14X516414XX	470	S	145	164	164.10	14							
14X517012XX	350	S	145	170	170.45	12							
14X517515XX	350	S	145	175	175.38	15							
14X518012XX	350	S	145	180	180.28	12							
14X518012XX	350	S	145	180	180.28	12							
14X817015XX	350	S	148	170	170.28	15							
14X817015XX	350	S	148	170	170.28	15							
15X018012XX	350	S	150	180	180.35	12							
15X018015XX	350	S	150	180	180.35	15							
15X518015XX	320	S	155	180	180.23	15							

Styles VS1, VS3, & VS4

Style VS2

Part Number	Style	Matl	Shaft Diameter Range* (d1)		Shaft/mm (d1)	Width on Shaft (A)	Overall Width (B)	Fitted Width (B1)	Width Tolerance (+/-)	Height (C)
800030	VS1	S	0.11	0.14	3	0.08	0.12	0.10	0.012	0.06
800034	VS1	V	0.11	0.14	3	0.08	0.12	0.10	0.012	0.06
800040	VS1	S	0.14	0.18	4	0.09	0.15	0.12	0.016	0.08
800044	VS1	V	0.14	0.18	4	0.09	0.15	0.12	0.016	0.08
800050	VS1	S	0.18	0.21	5	0.09	0.15	0.12	0.016	0.08
800051	VS2	S	0.18	0.21	5	0.15	0.21	0.18	0.016	0.08
800054	VS1	V	0.18	0.21	5	0.09	0.15	0.12	0.016	0.08
800055	VS2	V	0.18	0.21	5	0.15	0.21	0.18	0.016	0.08
800060	VS1	S	0.21	0.26	6	0.09	0.15	0.12	0.016	0.08
800061	VS2	S	0.21	0.26	6	0.15	0.21	0.18	0.016	0.08
800064	VS1	V	0.21	0.26	6	0.09	0.15	0.12	0.016	0.08
800065	VS2	V	0.21	0.26	6	0.15	0.21	0.18	0.016	0.08
800070	VS1	S	0.26	0.31	7	0.09	0.15	0.12	0.016	0.08
800071	VS2	S	0.26	0.31	7	0.15	0.21	0.18	0.016	0.08
800074	VS1	V	0.26	0.31	7	0.09	0.15	0.12	0.016	0.08
800075	VS2	V	0.26	0.31	7	0.15	0.21	0.18	0.016	0.08
800080	VS1	S	0.31	0.37	8	0.09	0.15	0.12	0.016	0.08
800081	VS2	S	0.31	0.37	8	0.15	0.21	0.18	0.016	0.08
800084	VS1	V	0.31	0.37	8	0.09	0.15	0.12	0.016	0.08
800085	VS2	V	0.31	0.37	8	0.15	0.21	0.18	0.016	0.08
800100	VS1	S	0.37	0.45	10	0.13	0.22	0.18	0.020	0.12
800101	VS2	S	0.37	0.45	10	0.22	0.30	0.26	0.020	0.12
800104	VS1	V	0.37	0.45	10	0.13	0.22	0.18	0.020	0.12
800105	VS2	V	0.37	0.45	10	0.22	0.30	0.26	0.020	0.12
800120	VS1	S	0.45	0.49	12	0.13	0.22	0.18	0.020	0.12
800121	VS2	S	0.45	0.49	12	0.22	0.30	0.26	0.020	0.12
800124	VS1	V	0.45	0.49	12	0.13	0.22	0.18	0.020	0.12
800125	VS2	V	0.45	0.49	12	0.22	0.30	0.26	0.020	0.12
800130	VS1	S	0.49	0.53	13	0.13	0.22	0.18	0.020	0.12
800134	VS1	V	0.49	0.53	13	0.13	0.22	0.18	0.020	0.12

* Select the larger V-Seal when the dimension d1 is on the boundary between two sizes of V-Seals

Part Number	Style	Matl	Shaft Diameter Range* (d1)		Shaft/mm (d1)	Width on Shaft (A)	Overall Width (B)	Fitted Width (B1)	Width Tolerance (+/-)	Height (C)
800140	VS1	S	0.53	0.61	14	0.13	0.22	0.18	0.020	0.12
800141	VS2	S	0.53	0.61	14	0.22	0.30	0.26	0.020	0.12
800144	VS1	V	0.53	0.61	14	0.13	0.22	0.18	0.020	0.12
800145	VS2	V	0.53	0.61	14	0.22	0.30	0.26	0.020	0.12
800160	VS1	S	0.61	0.69	16	0.13	0.22	0.18	0.020	0.12
800161	VS2	S	0.61	0.69	16	0.22	0.30	0.26	0.020	0.12
800164	VS1	V	0.61	0.69	16	0.13	0.22	0.18	0.020	0.12
800165	VS2	V	0.61	0.69	16	0.22	0.30	0.26	0.020	0.12
800180	VS1	S	0.69	0.75	18	0.13	0.22	0.18	0.020	0.12
800181	VS2	S	0.69	0.75	18	0.22	0.30	0.26	0.020	0.12
800184	VS1	V	0.69	0.75	18	0.13	0.22	0.18	0.020	0.12
800185	VS2	V	0.69	0.75	18	0.22	0.30	0.26	0.020	0.12
800200	VS1	S	0.75	0.83	20	0.18	0.30	0.24	0.030	0.16
800201	VS2	S	0.75	0.83	20	0.31	0.41	0.35	0.030	0.16
800204	VS1	V	0.75	0.83	20	0.18	0.30	0.24	0.030	0.16
800205	VS2	V	0.75	0.83	20	0.31	0.41	0.35	0.030	0.16
800220	VS1	S	0.83	0.95	22	0.18	0.30	0.24	0.030	0.16
800221	VS2	S	0.83	0.95	22	0.31	0.41	0.35	0.030	0.16
800224	VS1	V	0.83	0.95	22	0.18	0.30	0.24	0.030	0.16
800225	VS2	V	0.93	0.95	22	0.31	0.41	0.35	0.030	0.16
800250	VS1	S	0.95	1.07	25	0.18	0.30	0.24	0.030	0.16
800251	VS2	S	0.96	1.07	25	0.31	0.41	0.35	0.030	0.16
800254	VS1	V	0.95	1.07	25	0.18	0.30	0.24	0.030	0.16
800255	VS2	V	0.95	1.07	25	0.31	0.41	0.35	0.030	0.16
800280	VS1	S	1.07	1.14	28	0.18	0.30	0.24	0.030	0.16
800281	VS2	S	1.07	1.14	28	0.31	0.41	0.35	0.030	0.16
800284	VS1	V	1.07	1.14	28	0.18	0.30	0.24	0.030	0.16
800285	VS2	V	1.07	1.14	28	0.31	0.41	0.35	0.030	0.16
800300	VS1	S	1.14	1.22	30	0.18	0.30	0.24	0.030	0.16
800301	VS2	S	1.14	1.22	30	0.31	0.41	0.35	0.030	0.16
800304	VS1	V	1.14	1.22	30	0.18	0.30	0.24	0.030	0.16
800305	VS2	V	1.14	1.22	30	0.31	0.41	0.35	0.030	0.16
800320	VS1	S	1.22	1.30	32	0.18	0.30	0.24	0.030	0.16
800321	VS2	S	1.22	1.30	32	0.31	0.41	0.35	0.030	0.16
800324	VS1	V	1.22	1.30	32	0.18	0.30	0.24	0.030	0.16
800325	VS2	V	1.22	1.30	32	0.31	0.41	0.35	0.030	0.16
800350	VS1	S	1.30	1.42	35	0.18	0.30	0.24	0.030	0.16
800351	VS2	S	1.30	1.42	35	0.31	0.41	0.35	0.030	0.16
800354	VS1	V	1.30	1.42	35	0.18	0.30	0.24	0.030	0.16
800355	VS2	V	1.30	1.42	36	0.31	0.41	0.35	0.030	0.16
800380	VS1	S	1.42	1.50	38	0.18	0.30	0.24	0.030	0.16
800381	VS2	S	1.42	1.50	38	0.31	0.41	0.35	0.030	0.16
800384	VS1	V	1.42	1.50	38	0.18	0.30	0.24	0.030	0.16
800385	VS2	V	1.42	1.50	38	0.31	0.41	0.35	0.030	0.16
800400	VS1	S	1.50	1.70	40	0.21	0.35	0.28	0.040	0.20
800401	VS2	S	1.50	1.70	40	0.37	0.51	0.43	0.040	0.20
800404	VS1	V	1.50	1.70	40	0.21	0.35	0.28	0.040	0.20
800405	VS2	V	1.50	1.70	40	0.37	0.51	0.43	0.040	0.20
800450	VS1	S	1.70	1.89	45	0.21	0.35	0.28	0.040	0.20
800451	VS2	S	1.70	1.89	45	0.37	0.51	0.43	0.040	0.20

Styles VS1, VS3, & VS4

Style VS2

Part Number	Style	Matl	Shaft Diameter Range* (d1)		Shaft/mm (d1)	Width on Shaft (A)	Overall Width (B)	Fitted Width (B1)	Width Tolerance (+/-)	Height (C)
800454	VS1	V	1.70	1.89	45	0.21	0.35	0.28	0.040	0.20
800455	VS2	V	1.70	1.89	45	0.37	0.51	0.43	0.040	0.20
800500	VS1	S	1.89	2.09	50	0.21	0.35	0.28	0.040	0.20
800501	VS2	S	1.89	2.09	50	0.37	0.51	0.43	0.040	0.20
800504	VS1	V	1.89	2.09	50	0.21	0.35	0.28	0.040	0.20
800505	VS2	V	1.89	2.09	50	0.37	0.51	0.43	0.040	0.20
800550	VS1	S	2.09	2.29	55	0.21	0.35	0.28	0.040	0.20
800551	VS2	S	2.09	2.29	55	0.37	0.51	0.43	0.040	0.20
800554	VS1	V	2.09	2.29	55	0.21	0.35	0.28	0.040	0.20
800555	VS2	V	2.09	2.29	55	0.37	0.51	0.43	0.040	0.20
800600	VS1	S	2.29	2.48	60	0.21	0.35	0.28	0.040	0.20
800601	VS2	S	2.29	2.48	60	0.37	0.51	0.43	0.040	0.20
800604	VS1	V	2.29	2.48	60	0.21	0.35	0.28	0.040	0.20
800605	VS2	V	2.29	2.48	60	0.37	0.51	0.43	0.040	0.20
800650	VS1	S	2.48	2.68	65	0.21	0.35	0.28	0.040	0.20
800651	VS2	S	2.48	2.68	65	0.37	0.51	0.43	0.040	0.20
800654	VS1	V	2.48	2.68	65	0.21	0.35	0.28	0.040	0.20
800655	VS2	V	2.48	2.68	65	0.37	0.51	0.43	0.040	0.20
800700	VS1	S	2.68	2.88	70	0.26	0.43	0.35	0.050	0.24
800701	VS2	S	2.68	2.88	70	0.44	0.61	0.53	0.050	0.24
800704	VS1	V	2.68	2.88	70	0.26	0.43	0.35	0.050	0.24
800705	VS2	V	2.68	2.88	70	0.44	0.61	0.53	0.050	0.24
800750	VS1	S	2.88	3.07	75	0.26	0.43	0.35	0.050	0.24
800751	VS2	S	2.88	3.07	75	0.44	0.61	0.53	0.050	0.24
800754	VS1	V	2.88	3.07	75	0.26	0.43	0.35	0.050	0.24
800755	VS2	V	2.88	3.07	75	0.44	0.61	0.53	0.050	0.24
800800	VS1	S	3.07	3.27	80	0.26	0.43	0.35	0.050	0.24
800801	VS2	S	3.07	3.27	80	0.44	0.61	0.53	0.050	0.24
800804	VS1	V	3.07	3.27	80	0.26	0.43	0.35	0.050	0.24
800805	VS2	V	3.07	3.27	80	0.44	0.61	0.53	0.050	0.24

* Select the larger V-Seal when the dimension d1 is on the boundary between two sizes of V-Seals

Part Number	Style	Matl	Shaft Diameter Range* (d1)		Shaft/mm (d1)	Width on Shaft (A)	Overall Width (B)	Fitted Width (B1)	Width Tolerance (+/-)	Height (C)
800850	VS1	S	3.27	3.47	85	0.26	0.43	0.35	0.050	0.24
800851	VS2	S	3.27	3.47	85	0.44	0.61	0.53	0.050	0.24
800854	VS1	V	3.27	3.47	85	0.26	0.43	0.35	0.050	0.24
800855	VS2	V	3.27	3.47	85	0.44	0.61	0.53	0.050	0.24
800900	VS1	S	3.47	3.66	90	0.26	0.43	0.35	0.050	0.24
800901	VS2	S	3.47	3.66	90	0.44	0.61	0.53	0.050	0.24
800904	VS1	V	3.47	3.66	90	0.26	0.43	0.35	0.050	0.24
800905	VS2	V	3.47	3.66	90	0.44	0.61	0.53	0.050	0.24
800950	VS1	S	3.66	3.86	95	0.26	0.43	0.35	0.050	0.24
800951	VS2	S	3.66	3.86	95	0.44	0.61	0.53	0.050	0.24
800954	VS1	V	3.66	3.86	95	0.26	0.43	0.35	0.050	0.24
800955	VS2	V	3.66	3.86	95	0.44	0.61	0.53	0.050	0.24
801000	VS1	S	3.86	4.14	100	0.26	0.43	0.35	0.050	0.24
801001	VS2	S	3.86	4.14	100	0.44	0.61	0.53	0.050	0.24
801004	VS1	V	3.86	4.14	100	0.26	0.43	0.35	0.050	0.24
801005	VS2	V	3.86	4.14	100	0.44	0.61	0.53	0.050	0.24
801100	VS1	S	4.14	4.53	110	0.31	0.50	0.41	0.060	0.28
801101	VS2	S	4.14	4.53	110	0.52	0.71	0.61	0.060	0.28
801104	VS1	V	4.14	4.53	110	0.31	0.50	0.41	0.060	0.28
801105	VS2	V	4.14	4.53	110	0.52	0.71	0.61	0.060	0.28
801200	VS1	S	4.53	4.92	120	0.31	0.50	0.41	0.060	0.28
801201	VS2	S	4.53	4.92	120	0.52	0.71	0.61	0.060	0.28
801204	VS1	V	4.53	4.92	120	0.31	0.50	0.41	0.060	0.28
801205	VS2	V	4.53	4.92	120	0.52	0.71	0.61	0.060	0.28
801300	VS1	S	4.92	5.32	130	0.31	0.50	0.41	0.060	0.28
801301	VS2	S	4.92	5.32	130	0.52	0.71	0.61	0.060	0.28
801304	VS1	V	4.92	5.32	130	0.31	0.50	0.41	0.060	0.28
801305	VS2	V	4.92	5.32	130	0.52	0.71	0.61	0.060	0.28
801400	VS1	S	5.32	5.71	140	0.31	0.50	0.41	0.060	0.28
801401	VS2	S	5.32	5.71	140	0.52	0.71	0.61	0.060	0.28
801402	VS3	S	5.32	5.71	140	0.24	0.41	0.31	0.060	0.26
801404	VS1	V	5.32	5.71	140	0.31	0.50	0.41	0.060	0.28
801405	VS2	V	5.32	5.71	140	0.52	0.71	0.61	0.060	0.28
801406	VS3	V	5.32	5.71	140	0.24	0.41	0.31	0.060	0.26
801500	VS1	S	5.71	6.10	150	0.31	0.50	0.41	0.060	0.28
801501	VS2	S	5.71	6.10	150	0.52	0.71	0.61	0.060	0.28
801502	VS3	S	5.71	6.10	150	0.24	0.41	0.31	0.060	0.26
801504	VS1	V	5.71	6.10	150	0.31	0.50	0.41	0.060	0.28
801505	VS2	V	5.71	6.10	150	0.52	0.71	0.61	0.060	0.28
801506	VS3	V	5.71	6.10	150	0.24	0.41	0.31	0.060	0.26
801600	VS1	S	6.10	6.50	160	0.35	0.57	0.47	0.070	0.32
801601	VS2	S	6.10	6.50	160	0.59	0.81	0.71	0.070	0.32
801602	VS3	S	6.10	6.50	160	0.24	0.41	0.31	0.060	0.26
801604	VS1	V	6.10	6.50	160	0.35	0.57	0.47	0.070	0.32
801605	VS2	V	6.10	6.50	160	0.59	0.81	0.71	0.070	0.32
801606	VS3	V	6.10	6.50	160	0.24	0.41	0.31	0.060	0.26
801700	VS1	S	6.50	6.89	170	0.35	0.57	0.47	0.070	0.32
801701	VS2	S	6.50	6.89	170	0.59	0.81	0.71	0.070	0.32
801702	VS3	S	6.50	6.89	170	0.24	0.41	0.31	0.060	0.26
801704	VS1	V	6.50	6.89	170	0.35	0.57	0.47	0.070	0.32

Styles VS1, VS3, & VS4

Style VS2

Part Number	Style	Matl	Shaft Diameter Range* (d1)		Shaft/mm (d1)	Width on Shaft (A)	Overall Width (B)	Fitted Width (B1)	Width Tolerance (+/-)	Height (C)
801705	VS2	V	6.50	6.89	170	0.59	0.81	0.71	0.070	0.32
801706	VS3	V	6.50	6.89	170	0.24	0.41	0.31	0.060	0.26
801800	VS1	S	6.89	7.29	180	0.35	0.57	0.47	0.070	0.32
801801	VS2	S	6.89	7.29	180	0.59	0.81	0.71	0.070	0.32
801802	VS3	S	6.89	7.29	180	0.24	0.41	0.31	0.060	0.26
801804	VS1	V	6.89	7.29	180	0.35	0.57	0.47	0.070	0.32
801805	VS2	V	6.89	7.29	180	0.59	0.81	0.71	0.070	0.32
801806	VS3	V	6.89	7.29	180	0.24	0.41	0.31	0.060	0.26
801900	VS1	S	7.29	7.68	190	0.35	0.57	0.47	0.070	0.32
801901	VS2	S	7.29	7.68	190	0.59	0.81	0.71	0.070	0.32
801902	VS3	S	7.29	7.68	190	0.24	0.41	0.31	0.060	0.26
801904	VS1	V	7.29	7.68	190	0.35	0.57	0.47	0.070	0.32
801905	VS2	V	7.29	7.68	190	0.59	0.81	0.71	0.070	0.32
801906	VS3	V	7.29	7.68	190	0.24	0.41	0.31	0.060	0.26
801990	VS1	S	7.68	8.27	199	0.35	0.57	0.47	0.070	0.32
801991	VS2	S	7.68	8.27	199	0.59	0.81	0.71	0.070	0.32
801994	VS1	V	7.68	8.27	199	0.35	0.57	0.47	0.070	0.32
801995	VS2	V	7.68	8.27	199	0.59	0.81	0.71	0.070	0.32
802000	VS1	S	7.48	8.27	200	0.56	0.98	0.79	0.160	0.59
802002	VS3	S	7.48	8.27	200	0.24	0.41	0.31	0.060	0.26
802004	VS1	V	7.48	8.27	200	0.56	0.98	0.79	0.160	0.59
802006	VS3	V	7.48	8.27	200	0.24	0.41	0.31	0.060	0.26
802200	VS1	S	8.27	9.25	220	0.56	0.98	0.79	0.160	0.59
802202	VS3	S	8.27	9.25	220	0.24	0.41	0.31	0.060	0.26
802204	VS1	V	8.27	9.25	220	0.56	0.98	0.79	0.160	0.59
802206	VS3	V	8.27	9.25	220	0.24	0.41	0.31	0.060	0.26
802500	VS1	S	9.25	10.43	250	0.56	0.98	0.79	0.160	0.59
802502	VS3	S	9.25	10.43	250	0.24	0.41	0.31	0.060	0.26
802504	VS1	V	9.25	10.43	250	0.56	0.98	0.79	0.160	0.59
802506	VS3	V	9.25	10.43	250	0.24	0.41	0.31	0.060	0.26

* Select the larger V-Seal when the dimension d1 is on the boundary between two sizes of V-Seals

Part Number	Style	Matl	Shaft Diameter Range* (d1)		Shaft/mm (d1)	Width on Shaft (A)	Overall Width (B)	Fitted Width (B1)	Width Tolerance (+/-)	Height (C)
802750	VS1	S	10.43	11.42	275	0.56	0.98	0.79	0.160	0.59
802752	VS3	S	10.43	11.42	275	0.24	0.41	0.31	0.060	0.26
802754	VS1	V	10.43	11.42	275	0.56	0.98	0.79	0.160	0.59
802756	VS3	V	10.43	11.42	275	0.24	0.41	0.31	0.060	0.26
803000	VS1	S	11.42	12.20	300	0.56	0.98	0.79	0.160	0.59
803002	VS3	S	11.42	12.20	300	0.22	0.41	0.31	0.060	0.26
803004	VS1	V	11.42	12.20	300	0.56	0.98	0.79	0.160	0.59
803006	VS3	V	11.42	12.20	300	0.24	0.41	0.31	0.060	0.26
803250	VS1	S	12.20	13.19	325	0.56	0.98	0.79	0.160	0.59
803252	VS3	S	12.20	13.19	325	0.24	0.41	0.31	0.060	0.26
803254	VS1	V	12.20	13.19	325	0.56	0.98	0.79	0.160	0.59
803256	VS3	V	12.20	13.19	325	0.24	0.41	0.31	0.060	0.26
803500	VS1	S	13.19	14.37	350	0.56	0.98	0.79	0.160	0.59
803502	VS3	S	13.19	14.37	350	0.24	0.41	0.31	0.060	0.26
803504	VS1	V	13.19	14.37	350	0.56	0.98	0.79	0.160	0.59
803506	VS3	V	13.19	14.37	350	0.24	0.41	0.31	0.060	0.26
803750	VS1	S	14.37	15.35	375	0.56	0.98	0.79	0.160	0.59
803752	VS3	S	14.37	15.35	375	0.24	0.41	0.31	0.060	0.26
803754	VS1	V	14.37	15.35	375	0.56	0.98	0.79	0.160	0.59
803756	VS3	V	14.37	15.35	375	0.24	0.41	0.31	0.060	0.26
804000	VS1	S	15.35	16.93	400	0.56	0.98	0.79	0.160	0.59
804002	VS3	S	15.35	16.93	400	0.24	0.41	0.31	0.060	0.26
804004	VS1	V	15.35	16.93	400	0.56	0.98	0.79	0.160	0.59
804006	VS3	V	15.35	16.93	400	0.24	0.41	0.31	0.060	0.26
804500	VS1	S	16.93	18.90	450	0.56	0.98	0.79	0.160	0.59
804502	VS3	S	16.93	18.90	450	0.24	0.41	0.31	0.060	0.26
804503	VS4	S	17.72	17.91	450	0.56	0.98	0.79	0.160	0.59
804504	VS1	V	16.93	18.90	450	0.56	0.98	0.79	0.160	0.59
804506	VS3	V	16.93	18.90	450	0.24	0.41	0.31	0.060	0.26
805000	VS1	S	18.90	20.87	500	0.56	0.98	0.79	0.160	0.59
805002	VS3	S	18.90	20.87	500	0.24	0.41	0.31	0.060	0.26
805003	VS4	S	19.69	19.88	500	0.56	0.98	0.79	0.160	0.59
805004	VS1	V	18.90	20.87	500	0.56	0.98	0.79	0.160	0.59
805103	VS4	S	2.08	20.28	510	0.56	0.98	0.79	0.160	0.59
805203	VS4	S	20.47	20.67	520	0.56	0.98	0.79	0.160	0.59
805303	VS4	S	20.87	21.06	530	0.56	0.98	0.79	0.160	0.59
805403	VS4	S	21.26	21.46	540	0.56	0.98	0.79	0.160	0.59
805500	VS1	S	20.87	22.86	550	0.56	0.98	0.79	0.160	0.59
805502	VS3	S	20.87	22.83	550	0.24	0.41	0.31	0.060	0.26
805503	VS4	S	21.65	21.85	550	0.56	0.98	0.79	0.160	0.59
805504	VS1	V	20.87	22.83	550	0.56	0.98	0.79	0.160	0.59
805603	VS4	S	22.05	22.24	560	0.56	0.98	0.79	0.160	0.59
805703	VS4	S	22.44	22.64	570	0.56	0.98	0.79	0.160	0.59
805803	VS4	S	22.84	23.03	580	0.56	0.98	0.79	0.160	0.59
805903	VS4	S	23.23	23.62	590	0.56	0.98	0.79	0.160	0.59
806000	VS1	S	22.83	24.80	600	0.56	0.98	0.79	0.160	0.59
806002	VS3	S	22.83	24.80	600	0.24	0.41	0.31	0.060	0.26
806003	VS4	S	23.62	24.02	600	0.56	0.98	0.79	0.160	0.59
806004	VS1	V	22.83	24.80	600	0.56	0.98	0.79	0.160	0.59
806103	VS4	S	24.02	24.41	610	0.56	0.98	0.79	0.160	0.59

Styles VS1, VS3, & VS4

Style VS2

Part Number	Style	Matl	Shaft Diameter Range* (d1)		Shaft/mm (d1)	Width on Shaft (A)	Overall Width (B)	Fitted Width (B1)	Width Tolerance (+/-)	Height (C)
806203	VS4	S	24.41	24.80	620	0.56	0.98	0.79	0.160	0.59
806303	VS4	S	24.80	25.20	630	0.56	0.98	0.79	0.160	0.59
806403	VS4	S	25.20	25.59	640	0.56	0.98	0.79	0.160	0.59
806500	VS1	S	24.80	26.18	650	0.56	0.98	0.79	0.160	0.59
806503	VS4	S	25.59	25.98	650	0.56	0.98	0.79	0.160	0.59
806903	VS4	S	27.10	27.50	690	0.56	0.98	0.79	0.160	0.59
807000	VS1	S	26.18	27.76	700	0.56	0.98	0.79	0.160	0.59
807003	VS4	S	27.56	27.95	700	0.56	0.98	0.79	0.160	0.59
807250	VS1	S	27.76	29.33	725	0.56	0.98	0.79	0.160	0.59
807500	VS1	S	29.33	30.91	750	0.56	0.98	0.79	0.160	0.59
807503	VS4	S	29.53	29.84	750	0.56	0.98	0.79	0.160	0.59
807803	VS4	S	30.40	30.80	780	0.56	0.98	0.79	0.160	0.59
808000	VS1	S	30.91	32.68	800	0.56	0.98	0.79	0.160	0.59
808003	VS4	S	31.18	31.54	800	0.56	0.98	0.79	0.160	0.59
808203	VS4	S	31.50	33.26	820	0.56	0.98	0.79	0.160	0.59
808500	VS1	S	32.68	34.45	850	0.56	0.98	0.79	0.160	0.59
808503	VS4	S	33.11	33.50	850	0.56	0.98	0.79	0.160	0.59
809000	VS1	S	34.45	36.22	900	0.56	0.98	0.79	0.160	0.59
809003	VS4	S	35.12	35.91	900	0.56	0.98	0.79	0.160	0.59
809500	VS1	S	36.22	37.99	950	0.56	0.98	0.79	0.160	0.59
809503	VS4	S	37.17	37.60	950	0.56	0.98	0.79	0.160	0.59
810000	VS1	S	37.99	39.96	1000	0.56	0.98	0.79	0.160	0.59
810003	VS4	S	39.33	39.79	1000	0.56	0.98	0.79	0.160	0.59
810500	VS1	S	39.96	41.93	1050	0.56	0.98	0.79	0.160	0.59
810603	VS4	S	41.10	41.90	1060	0.56	0.98	0.79	0.160	0.59
811000	VS1	S	41.93	43.90	1100	0.56	0.98	0.79	0.160	0.59
811003	VS4	S	42.72	43.50	1100	0.56	0.98	0.79	0.160	0.59
811500	VS1	S	43.90	45.87	1150	0.56	0.98	0.79	0.160	0.59
812000	VS1	S	45.87	47.84	1200	0.56	0.98	0.79	0.160	0.59
812003	VS4	S	46.65	47.44	1200	0.56	0.98	0.79	0.160	0.59

* Select the larger V-Seal when the dimension d1 is on the boundary between two sizes of V-Seals

Part Number	Style	Matl	Shaft Diameter Range* (d1)		Shaft/mm (d1)	Width on Shaft (A)	Overall Width (B)	Fitted Width (B1)	Width Tolerance (+/-)	Height (C)
812500	VS1	S	47.84	50.00	1250	0.56	0.98	0.79	0.160	0.59
813000	VS1	S	50.00	51.97	1300	0.56	0.98	0.79	0.160	0.59
813003	VS4	S	50.98	51.77	1300	0.56	0.98	0.79	0.160	0.59
813500	VS1	S	51.97	53.94	1300	0.56	0.98	0.79	0.160	0.59
813503	VS4	S	52.76	53.74	1350	0.56	0.98	0.79	0.160	0.59
814000	VS1	S	53.94	55.91	1400	0.56	0.98	0.79	0.160	0.59
814003	VS4	S	54.72	55.71	1400	0.56	0.98	0.79	0.160	0.59
814500	VS1	S	55.91	57.87	1450	0.56	0.98	0.79	0.160	0.59
814503	VS4	S	56.69	57.68	1450	0.56	0.98	0.79	0.160	0.59
815000	VS1	S	57.87	59.84	1500	0.56	0.98	0.79	0.160	0.59
815003	VS4	S	58.66	59.65	1500	0.56	0.98	0.79	0.160	0.59
815500	VS1	S	59.84	61.81	1550	0.56	0.98	0.79	0.160	0.59
815503	VS4	S	60.63	61.81	1550	0.56	0.98	0.79	0.160	0.59
816000	VS1	S	61.81	63.78	1600	0.56	0.98	0.79	0.160	0.59
816003	VS4	S	62.99	64.57	1600	0.56	0.98	0.79	0.160	0.59
816500	VS1	S	63.78	65.75	1650	0.56	0.98	0.79	0.160	0.59
816503	VS4	S	64.57	66.14	1650	0.56	0.98	0.79	0.160	0.59
817000	VS1	S	65.75	67.72	1700	0.56	0.98	0.79	0.160	0.59
817003	VS4	S	66.15	67.72	1700	0.56	0.98	0.79	0.160	0.59
817500	VS1	S	67.72	69.69	1750	0.56	0.98	0.79	0.160	0.59
817503	VS4	S	67.72	69.49	1750	0.56	0.98	0.79	0.160	0.59
818000	VS1	S	69.69	71.65	1800	0.56	0.98	0.79	0.160	0.59
818003	VS4	S	69.46	71.26	1800	0.56	0.98	0.79	0.160	0.59
818500	VS1	S	71.65	73.62	1850	0.56	0.98	0.79	0.160	0.59
818503	VS4	S	71.26	73.03	1850	0.56	0.98	0.79	0.160	0.59
819000	VS1	S	73.62	75.59	1900	0.56	0.98	0.79	0.160	0.59
819003	VS4	S	73.03	75.00	1900	0.56	0.98	0.79	0.160	0.59
819500	VS1	S	75.59	77.56	1950	0.56	0.98	0.79	0.160	0.59
819503	VS4	S	75.00	76.97	1950	0.56	0.98	0.79	0.160	0.59
819990	VS1	S	77.56	79.53	1999	0.56	0.98	0.79	0.160	0.59
820003	VS4	S	76.90	79.10	2000	0.56	0.98	0.79	0.160	0.59

Part Number	Style	Matl	Shaft	Bore	O.D.	Width
370001A	Unitized	S	3.500	4.842	4.848	0.925
370002A	Unitized	S	3.500	5.000	5.006	1.000
370003A	Unitized	S	4.765	6.311	6.318	1.078
370004A	Unitized	S	4.812	6.500	6.507	0.865
370005A	Unitized	S	4.765	6.251	6.265	0.605
370006A	Unitized	S	4.765	6.999	7.006	1.250
370007A	Unitized	S	4.875	6.373	6.379	0.921
370008A	Unitized	S	3.937	5.372	5.378	1.015
370009A	Unitized	S	3.937	5.501	5.507	0.937
370010A	Unitized	S	2.875	4.125	4.130	0.842
370011A	Unitized	S	3.625	5.000	5.014	0.875
370012A	Unitized	S	3.625	4.810	4.823	0.921
370013A	Unitized	S	3.312	5.000	5.006	0.937
370014A	Unitized	S	3.125	4.500	4.506	0.605
370015A	Unitized	S	4.000	5.375	5.381	1.000
370018A	Unitized	S	3.250	4.500	4.506	0.605
370019A	Unitized	S	4.375	6.251	6.256	0.605
370020A	Unitized	S	4.500	6.000	6.007	0.984
370021A	Unitized	S	4.500	6.251	6.265	0.610
370022A	Unitized	S	4.500	5.750	5.756	0.960
370023A	Unitized	S	3.875	5.690	5.706	0.875
370024A	Unitized	S	3.875	5.501	5.515	0.875
370025A	Unitized	S	4.625	5.999	6.008	0.840
370026A	Unitized	S	4.635	6.007	6.014	0.937
370027A	Unitized	S	4.812	6.311	6.316	1.062
370028A	Unitized	S	5.000	6.250	6.256	1.375
370029A	Unitized	S	3.187	5.000	5.006	0.765
370030A	Unitized	S	4.265	6.064	6.071	0.605
370031A	Unitized	S	4.250	6.250	6.256	1.188
370033A	Unitized	S	3.875	5.126	5.132	0.605
370034A	Unitized	S	4.375	6.311	6.317	1.090
370036A	Unitized	S	4.000	5.757	5.772	0.930
370037A	Unitized	S	4.375	5.757	5.763	1.000
370038A	Unitized	S	5.000	7.437	7.444	0.605
370039A	Unitized	S	5.500	7.437	7.444	1.000
370043A	Unitized	S	5.500	7.125	7.132	1.187
370046A	Unitized	S	3.125	4.625	4.631	0.605
370047A	Unitized	S	3.437	4.755	4.761	0.605
370048A	Unitized	S	4.375	5.905	5.911	1.000
370051A	Unitized	S	4.625	6.622	6.629	1.093
370054A	Unitized	S	2.875	4.175	4.181	0.822
370057A	Unitized	S	4.875	6.437	6.444	0.921
370063A	Unitized	S	5.000	6.250	6.256	0.605
370064A	Unitized	S	5.625	7.186	7.194	0.906
370065A	Unitized	S	4.250	6.008	6.022	1.000
370066A	Unitized	S	4.000	5.626	5.632	0.605
370069A	Unitized	S	5.250	7.375	7.386	1.000
*370077A	Unitized	S	6.000	7.875	7.881	0.605
370078A	Unitized	S	4.500	6.622	6.629	1.093
*370082A	Unitized	S	7.375	9.054	9.063	1.062

Part Number	Style	Matl	Shaft	Bore	O.D.	Width
370086A	Unitized	S	4.500	6.310	6.316	1.175
*370087A	Unitized	S	4.000	5.248	5.254	0.605
370094A	Unitized	S	4.125	5.375	5.381	0.605
370106A	Unitized	S	4.166	5.500	5.506	0.605
370107A	Unitized	S	4.250	6.035	6.047	0.915
370109A	Unitized	S	4.875	6.622	6.629	1.000
370119A	Unitized	S	5.640	7.501	7.507	0.605
370120A	Unitized	S	5.500	7.250	7.256	1.187
370121A	Unitized	S	4.875	6.500	6.506	1.000
370124A	Unitized	S	4.500	5.375	5.391	0.984
*370127A	Unitized	S	2.752	3.937	3.942	0.565
370131A	Unitized	S	4.500	5.876	5.892	0.984
370132A	Unitized	S	3.500	4.543	4.558	0.788
370145A	Unitized	S	3.125	4.174	4.188	0.500
*370149A	Unitized	S	6.625	8.007	8.014	0.605
370150A	Unitized	S	2.875	3.875	3.889	0.500
*370151A	Unitized	S	7.875	10.234	10.242	0.605
*370154A	Unitized	S	5.000	7.000	7.006	1.000
*370155A	Unitized	S	2.740	3.937	3.942	0.565
370165A	Unitized	S	3.875	5.376	5.381	0.985
370166A	Unitized	S	5.000	6.622	6.629	1.093
370169A	Unitized	S	3.500	4.751	4.757	0.605
370173A	Unitized	S	4.765	6.250	6.257	1.050
370175A	Unitized	S	7.250	8.750	8.758	0.605
370178A	Unitized	S	4.500	5.500	5.515	0.675
370179A	Unitized	S	3.500	4.450	4.456	0.843
370181A	Unitized	S	4.765	5.999	6.006	1.031
370182A	Unitized	S	4.375	5.905	5.910	1.000
370191A	Unitized	S	3.312	4.501	4.506	0.605
370192A	Unitized	S	4.500	6.441	6.447	0.937
370195A	Unitized	S	4.875	6.001	6.015	0.625
370198A	Unitized	S	4.040	5.122	5.130	0.945
370199A	Unitized	V	2.359	3.938	3.952	0.575
370211A	Unitized	S	2.948	4.725	4.738	0.526
370212A	Unitized	V	3.539	5.277	5.291	0.604
370215A	Unitized	V	5.000	7.000	7.015	1.130
370216A	Unitized	S	4.625	5.999	6.006	0.890
370219A	Unitized	S	2.250	3.372	3.377	0.475
370220A	Unitized	S	4.724	5.906	5.912	0.590
*370223A	Unitized	S	2.938	3.750	3.765	0.530
*370224A	Unitized	S	4.768	6.999	7.039	0.735
370338A	Unitized	S	4.375	5.757	5.798	0.600
370349A	Unitized	S	4.000	5.757	5.798	0.600
370352A	Unitized	S	2.750	3.779	3.792	0.767
380001A	Unitized	T	3.500	4.842	4.847	0.910
380003A	Unitized	T	4.765	6.311	6.318	1.132
380022A	Unitized	T	4.500	5.750	5.756	0.960
380023A	Unitized	T	3.875	5.690	5.706	0.770
380025A	Unitized	T	4.625	5.999	6.005	0.937
380031A	Unitized	T	4.250	6.250	6.256	1.188

Part Number	Style	Matl	Shaft	Bore	O.D.	Width
380036A	Unitized	T	4.000	5.757	5.772	0.930
380048A	Unitized	T	4.375	5.905	5.918	1.015
380065A	Unitized	T	4.250	6.000	6.008	1.000
380131A	Unitized	T	4.500	5.876	5.892	0.984

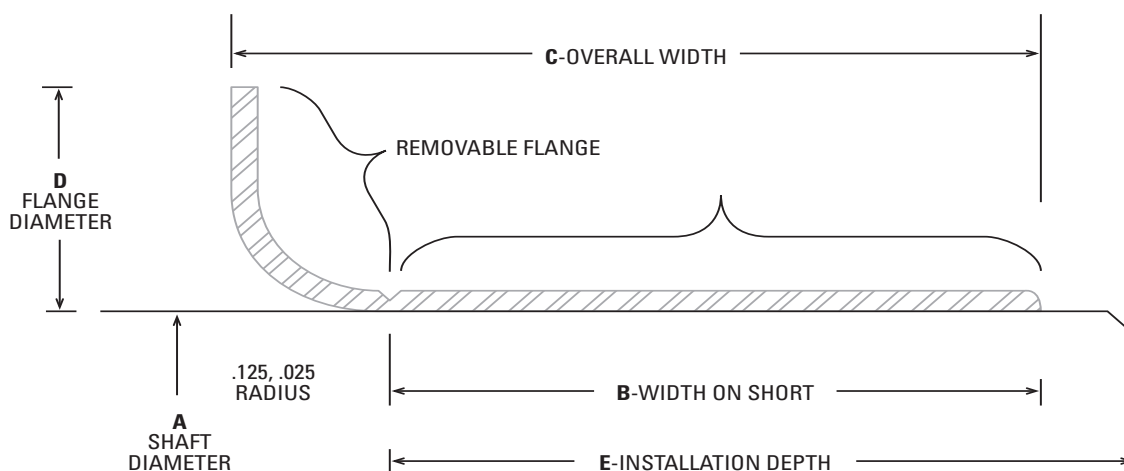

Part Number	Shaft Diameter Range (A)		Width on Shaft (B)	Overall Width (C)	Flange Diameter (D)	Installation (E)
KWK88176	1.761	1.767	0.563	0.688	2.063	0.813
KWK88179	1.778	1.784	0.675	0.800	2.125	1.000
KWK88186	1.866	1.872	0.889	1.025	2.187	1.000
KWK88187	1.872	1.878	0.563	0.688	2.203	1.000
KWK88199	1.997	2.003	0.563	0.688	2.406	1.000
KWK88218	2.186	2.192	0.781	0.938	2.500	1.313
KWK88225	2.249	2.255	0.781	0.938	2.531	1.313
KWK88233	2.327	2.333	0.750	0.875	2.750	1.610
KWK99049	0.469	0.475	0.236	0.331	0.787	0.472
KWK99050	0.498	0.502	0.250	0.344	0.610	2.008
KWK99056	0.560	0.566	0.250	0.391	0.750	1.831
KWK99058	0.626	0.630	0.313	0.438	0.718	2.000
KWK99059	0.589	0.593	0.197	0.354	0.750	0.425
KWK99060	0.682	0.686	0.313	0.438	0.900	2.000
KWK99062	0.623	0.627	0.313	0.406	0.813	2.000
KWK99068	0.667	0.671	0.315	0.433	1.063	2.008
KWK99075	0.748	0.752	0.375	0.500	0.900	2.000
KWK99076	0.748	0.752	0.313	0.438	0.938	2.000
KWK99078	0.785	0.789	0.313	0.433	0.999	2.000
KWK99080	0.780	0.784	0.313	0.438	0.935	2.000
KWK99081	0.759	0.761	0.313	0.438	0.938	2.000
KWK99082	0.704	0.709	0.315	0.433	1.063	1.811
KWK99085	0.861	0.866	0.315	0.472	1.058	1.813
KWK99086	0.857	0.861	0.250	0.375	1.155	2.000
KWK99087	0.873	0.877	0.313	0.438	1.093	2.000
KWK99091	0.908	0.912	0.313	0.438	1.218	1.847
KWK99094	0.966	0.970	0.313	0.438	1.130	2.000
KWK99096	0.966	0.970	0.625	0.719	1.130	2.000
KWK99098	0.982	0.986	0.313	0.433	1.378	2.000
KWK99101	0.998	1.002	0.313	0.438	1.219	2.000

Part Number	Shaft Diameter Range (A)		Width on Shaft (B)	Overall Width (C)	Flange Diameter (D)	Installation (E)
KWK99103	1.019	1.024	0.313	0.472	1.312	1.813
KWK99106	1.060	1.064	0.313	0.438	1.320	2.812
KWK99108	1.087	1.091	0.313	0.438	1.406	0.625
KWK99111	1.100	1.104	0.375	0.500	1.375	2.813
KWK99112	1.123	1.127	0.313	0.438	1.575	0.688
KWK99114	1.179	1.184	0.315	0.433	1.400	0.688
KWK99118	1.185	1.190	0.313	0.438	1.400	0.875
KWK99120	1.154	1.158	0.375	0.500	1.350	0.688
KWK99122	1.173	1.178	0.313	0.438	1.575	0.688
KWK99123	1.216	1.222	0.315	0.438	1.575	0.688
KWK99125	1.247	1.253	0.313	0.438	1.500	0.688
KWK99128	1.257	1.263	0.315	0.437	1.496	0.709
KWK99129	1.308	1.314	0.250	0.375	1.600	0.813
KWK99131	1.310	1.316	0.500	0.625	1.594	0.813
KWK99133	1.371	1.377	0.313	0.438	1.638	0.813
KWK99134	1.336	1.342	0.500	0.625	1.638	0.813
KWK99138	1.371	1.377	0.500	0.625	1.638	0.813
KWK99139	1.375	1.381	0.512	0.630	1.638	0.812
KWK99141	1.237	1.243	0.315	0.438	1.540	0.688
KWK99143	1.432	1.438	0.563	0.688	1.781	1.000
KWK99144	1.435	1.441	0.375	0.500	1.781	1.016
KWK99145	1.453	1.460	0.375	0.500	1.781	0.812
KWK99146	1.412	1.417	0.518	0.669	1.689	0.984
KWK99147	1.490	1.496	0.512	0.669	1.780	0.984
KWK99149	1.497	1.503	0.563	0.688	1.781	1.000
KWK99150	1.497	1.503	0.375	0.500	1.781	1.016
KWK99152	1.520	1.526	0.438	0.563	1.859	1.016
KWK99155	1.549	1.555	0.438	0.563	1.859	1.000
KWK99156	1.559	1.565	0.563	0.688	1.859	1.000
KWK99157	1.572	1.578	0.512	0.630	1.850	1.023
KWK99160	1.602	1.608	0.500	0.641	1.938	1.000
KWK99161	1.622	1.628	0.313	0.438	1.875	1.016
KWK99162	1.623	1.628	0.563	0.688	1.875	0.813
KWK99166	1.647	1.654	0.445	0.571	2.087	0.827
KWK99167	1.685	1.691	0.313	0.438	1.906	0.875
KWK99168	1.684	1.690	0.563	0.688	1.906	0.875
KWK99169	1.647	1.654	0.563	0.688	2.087	0.827
KWK99170	1.736	1.742	0.375	0.500	2.063	0.813
KWK99171	1.715	1.721	0.563	0.688	2.031	0.813
KWK99172	1.747	1.753	0.375	0.500	2.055	0.813
KWK99174	1.747	1.753	0.563	0.688	2.063	0.813
KWK99175	1.747	1.753	0.750	0.875	2.063	0.813
KWK99176	1.761	1.767	0.563	0.688	2.063	0.813
KWK99177	1.769	1.775	0.551	0.669	2.087	0.812
KWK99179	1.778	1.784	0.675	0.800	2.125	1.062
KWK99180	1.747	1.753	0.531	0.625	2.063	0.875
KWK99181	1.809	1.815	0.563	0.688	2.156	1.000
KWK99184	1.872	1.878	0.375	0.516	2.203	1.050
KWK99185	1.857	1.863	0.563	0.688	2.156	1.000
KWK99186	1.866	1.872	0.889	1.025	2.187	1.000

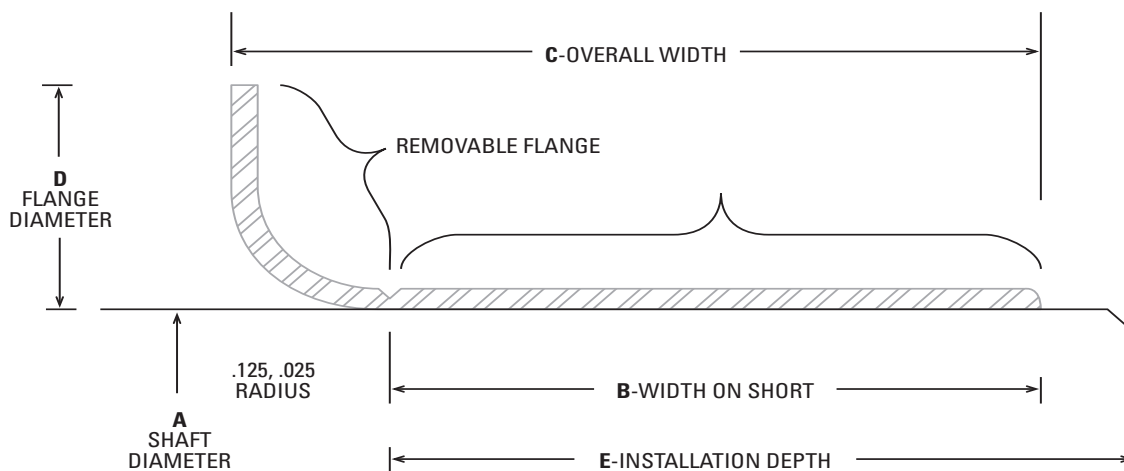

Part Number	Shaft Diameter Range (A)		Width on Shaft (B)	Overall Width (C)	Flange Diameter (D)	Installation (E)
KWK99187	1.872	1.878	0.563	0.688	2.203	1.000
KWK99188	1.872	1.878	0.295	0.415	2.203	0.744
KWK99189	1.887	1.893	0.551	0.668	2.205	0.984
KWK99190	1.872	1.878	0.175	0.295	2.203	0.744
KWK99192	1.909	1.915	0.375	0.500	2.219	1.000
KWK99193	1.934	1.940	0.563	0.688	2.219	1.000
KWK99196	1.965	1.971	0.551	0.688	2.244	0.984
KWK99198	1.977	1.983	0.563	0.704	2.313	1.050
KWK99199	1.997	2.003	0.563	0.688	2.406	1.000
KWK99200	1.997	2.003	0.875	1.000	2.406	1.000
KWK99204	2.041	2.047	0.500	0.625	2.469	1.000
KWK99205	2.057	2.063	0.781	0.938	2.469	1.375
KWK99210	2.123	2.128	0.500	0.750	2.422	1.281
KWK99212	2.124	2.130	0.781	0.938	2.422	1.375
KWK99215	2.162	2.168	0.787	0.905	2.441	1.250
KWK99218	2.186	2.192	0.781	0.938	2.500	1.313
KWK99220	2.197	2.205	0.500	0.625	2.500	1.250
KWK99225	2.249	2.255	0.781	0.938	2.531	1.313
KWK99226	2.237	2.243	0.764	0.900	2.562	1.250
KWK99227	2.249	2.255	0.313	0.438	2.531	1.313
KWK99229	2.227	2.233	0.500	0.625	2.531	1.313
KWK99230	2.227	2.233	0.781	0.906	2.531	1.250
KWK99231	2.309	2.315	0.781	0.938	2.688	1.600
KWK99233	2.327	2.333	0.750	0.875	2.750	1.610
KWK99235	2.359	2.365	0.787	0.905	2.785	1.375
KWK99236	2.369	2.375	0.781	0.938	2.750	1.375
KWK99237	2.374	2.380	0.781	0.938	2.734	1.375
KWK99238	2.372	2.378	0.594	0.750	2.750	1.375
KWK99240	2.374	2.380	0.526	0.683	2.750	1.375
KWK99241	2.359	2.365	0.370	0.449	2.783	1.472

Part Number	Shaft Diameter Range (A)		Width on Shaft (B)	Overall Width (C)	Flange Diameter (D)	Installation (E)
KWK99242	2.435	2.441	0.500	0.626	2.827	1.417
KWK99243	2.434	2.440	0.781	0.938	2.828	1.375
KWK99248	2.500	2.506	0.500	0.656	2.828	1.375
KWK99249	2.489	2.495	0.781	0.938	2.875	1.393
KWK99250	2.500	2.506	0.781	0.938	2.828	1.375
KWK99251	2.510	2.516	0.781	0.906	2.828	1.438
KWK99253	2.497	2.503	0.555	0.650	2.820	0.890
KWK99254	2.556	2.562	0.787	0.905	2.850	1.378
KWK99256	2.560	2.566	0.781	0.938	2.891	1.375
KWK99259	2.595	2.602	0.781	0.938	2.990	1.250
KWK99260	2.622	2.628	0.500	0.625	3.047	1.375
KWK99261	2.618	2.624	0.781	0.938	3.047	1.375
KWK99262	2.625	2.631	0.781	0.938	3.047	1.375
KWK99264	2.621	2.627	0.781	0.906	3.047	1.375
KWK99267	2.747	2.753	1.438	1.625	3.075	1.625
KWK99268	2.727	2.733	0.781	0.906	3.125	1.313
KWK99269	2.750	2.756	1.125	1.250	3.125	1.250
KWK99270	2.747	2.753	0.781	0.906	3.125	1.250
KWK99272	2.750	2.756	0.406	0.563	3.125	1.250
KWK99273	2.740	2.746	0.781	0.938	3.065	1.250
KWK99274	2.745	2.751	0.781	0.938	3.125	1.250
KWK99275	2.750	2.756	0.781	0.938	3.125	1.250
KWK99276	2.753	2.759	0.787	0.945	3.125	1.250
KWK99281	2.809	2.815	0.594	0.688	3.188	1.250
KWK99282	2.838	2.844	0.500	0.656	3.225	1.250
KWK99286	2.866	2.872	0.781	0.938	3.188	1.250
KWK99287	2.873	2.879	0.781	0.938	3.219	1.250
KWK99289	2.950	2.956	0.594	0.689	3.272	1.102
KWK99290	2.937	2.943	0.500	0.641	3.344	1.331
KWK99291	2.990	2.996	0.484	0.625	3.359	1.331
KWK99292	2.972	2.976	0.813	-	-	-
KWK99293	2.937	2.943	0.781	0.938	3.344	1.250
KWK99294	2.950	2.956	0.866	1.024	3.305	1.312
KWK99296	2.997	3.003	0.813	0.938	3.240	1.375
KWK99298	2.990	2.996	0.563	0.688	3.359	1.375
KWK99299	2.990	2.996	0.813	1.000	3.359	1.250
KWK99300	3.000	3.006	0.813	1.000	3.453	1.250
KWK99301	3.008	3.014	0.500	0.625	3.355	2.000
KWK99303	3.000	3.006	0.625	0.813	3.345	1.063
KWK99307	3.124	3.132	0.551	0.709	3.525	2.031
KWK99311	3.120	3.126	0.688	0.813	3.531	2.000
KWK99312	3.120	3.126	0.813	1.000	3.531	2.000
KWK99313	3.142	3.150	0.750	0.886	3.540	1.375
KWK99315	3.146	3.153	0.827	0.945	3.543	1.375
KWK99317	3.146	3.153	0.433	0.590	3.543	1.378
KWK99322	3.247	3.253	0.813	1.000	3.594	1.375
KWK99323	3.248	3.254	0.600	0.725	3.585	1.375
KWK99324	3.250	3.256	0.595	0.719	3.594	1.375
KWK99325	3.250	3.256	0.813	1.000	3.594	1.375
KWK99326	3.250	3.256	0.688	0.875	3.585	1.250

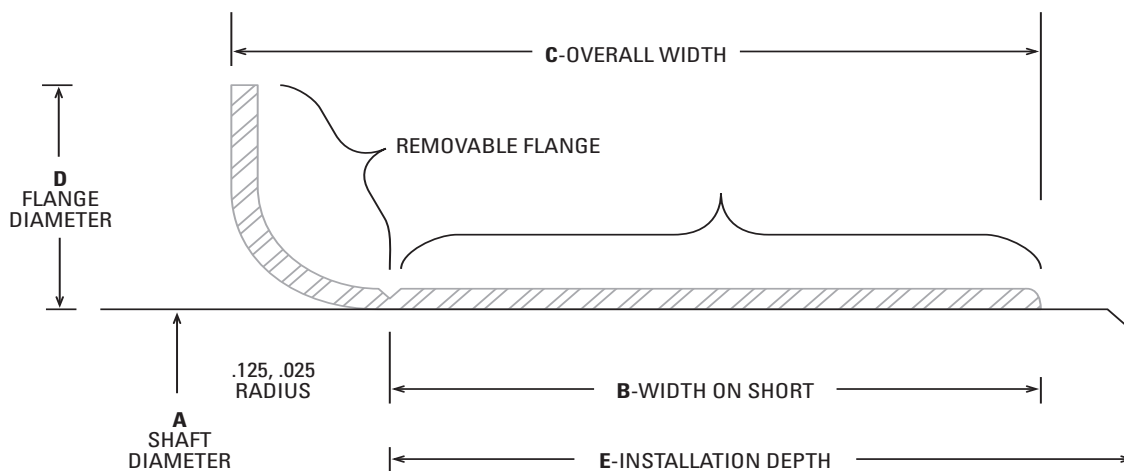

Part Number	Shaft Diameter Range (A)		Width on Shaft (B)	Overall Width (C)	Flange Diameter (D)	Installation (E)
KWK99328	3.225	3.231	0.661	0.850	3.587	1.732
KWK99331	3.307	3.313	0.813	1.000	3.688	1.375
KWK99333	3.337	3.346	0.827	0.984	3.700	1.378
KWK99334	3.338	3.346	0.827	0.984	3.697	1.433
KWK99337	3.373	3.379	0.813	1.000	3.688	1.375
KWK99338	3.373	3.379	0.375	0.500	3.688	1.410
KWK99339	3.435	3.441	0.781	0.906	3.844	1.406
KWK99340	3.477	3.483	0.781	0.906	3.835	1.406
KWK99347	3.500	3.506	0.315	0.500	3.827	1.339
KWK99349	3.501	3.507	0.626	0.811	3.842	1.339
KWK99350	3.500	3.506	0.813	1.000	3.844	1.375
KWK99351	3.540	3.546	0.710	0.906	4.000	1.813
KWK99353	3.540	3.546	0.528	0.665	4.000	1.732
KWK99354	3.540	3.546	0.906	1.102	4.000	1.750
KWK99356	3.560	3.566	0.813	1.000	3.900	1.750
KWK99359	3.685	3.691	0.813	0.938	4.025	1.750
KWK99360	3.618	3.624	0.811	1.000	4.031	1.732
KWK99362	3.623	3.629	0.813	1.000	4.031	1.750
KWK99363	3.623	3.629	0.500	0.625	4.025	1.750
KWK99364	3.740	3.746	0.469	0.594	4.035	1.750
KWK99365	3.685	3.691	0.813	0.938	4.025	1.750
KWK99367	3.750	3.756	0.344	0.500	4.031	1.750
KWK99368	3.684	3.690	0.313	0.438	3.830	0.375
KWK99369	3.737	3.743	0.827	0.945	4.025	1.750
KWK99372	3.750	3.756	0.688	0.875	4.031	1.875
KWK99374	3.740	3.746	0.344	0.500	4.031	1.750
KWK99376	3.746	3.752	0.563	0.688	4.025	1.750
KWK99387	3.873	3.879	0.813	1.000	4.219	1.875
KWK99393	3.935	3.941	0.813	1.000	4.313	1.340
KWK99395	3.998	4.006	0.600	0.725	-	2.050

Part Number	Shaft Diameter Range (A)		Width on Shaft (B)	Overall Width (C)	Flange Diameter (D)	Installation (E)
KWK99399	3.998	4.006	0.813	1.000	4.375	1.250
KWK99400	3.998	4.006	0.650	0.775	4.375	1.375
KWK99401	3.998	4.006	0.500	0.625	4.375	2.066
KWK99412	4.122	4.130	0.813	1.000	4.420	1.375
KWK99413	4.130	4.138	0.787	0.906	4.470	1.378
KWK99418	4.183	4.191	0.813	1.000	4.500	1.375
KWK99423	4.226	4.234	0.781	0.906	4.610	1.438
KWK99424	4.248	4.256	0.813	1.000	4.813	1.375
KWK99435	4.327	4.335	0.509	0.650	4.921	1.250
KWK99437	4.370	4.378	0.813	1.000	4.750	1.650
KWK99439	4.434	4.442	1.000	1.142	4.813	1.313
KWK99450	4.496	4.504	0.813	1.000	5.000	1.375
KWK99452	4.523	4.531	0.813	0.938	5.000	1.250
KWK99463	4.621	4.629	1.000	1.250	5.063	1.375
KWK99465	4.621	4.629	0.438	0.625	5.000	1.375
KWK99468	4.685	4.693	0.812	1.000	5.062	1.375
KWK99472	4.801	4.807	0.787	0.945	5.177	1.260
KWK99473	4.720	4.728	0.787	0.984	5.110	1.260
KWK99475	4.746	4.754	0.500	0.750	5.250	1.500
KWK99487	4.871	4.879	0.625	0.752	5.252	1.457
KWK99490	4.917	4.925	0.394	0.551	5.402	1.457
KWK99491	5.117	5.125	0.866	0.996	5.942	1.299
KWK99492	4.917	4.925	1.024	1.260	5.400	1.438
KWK99494	5.110	5.118	0.750	0.938	5.493	1.181
KWK99498	4.998	5.006	0.688	0.875	5.400	1.438
KWK99499	4.998	5.006	0.813	1.000	5.406	1.500
KWK99525	5.246	5.254	0.813	1.000	5.560	1.250
KWK99537	5.371	5.379	0.813	1.000	5.875	1.250
KWK99549	5.498	5.506	0.812	1.000	5.938	1.250
KWK99552	5.508	5.516	0.807	1.000	5.945	1.250
KWK99575	5.746	5.754	0.813	1.000	6.180	1.750
KWK99587	5.871	5.879	1.000	1.250	6.188	1.313
KWK99595	5.895	5.905	1.024	1.181	6.260	1.338
KWK99596	5.934	5.942	1.000	1.125	6.375	1.875
KWK99599	5.995	6.003	1.000	1.250	6.375	1.750
KWK99601	5.995	6.003	0.500	0.750	6.360	1.750
KWK99606	6.092	6.102	1.024	1.181	6.500	1.299
KWK99625	6.245	6.255	1.031	1.250	6.625	1.750
KWK99630	6.289	6.299	1.000	1.250	7.000	1.800
KWK99640	6.683	6.693	1.250	1.496	7.188	1.750
KWK99650	6.495	6.505	1.000	1.250	7.000	1.750
KWK99675	6.745	6.755	0.813	1.063	7.125	1.750
KWK99700	6.995	7.005	1.000	1.250	7.500	1.750
KWK99721	7.077	7.087	1.300	1.496	7.500	1.752
KWK99725	7.244	7.254	1.250	1.500	7.760	2.175
KWK99750	7.495	7.505	0.813	1.000	7.875	1.250
KWK99775	7.745	7.755	1.000	1.313	8.270	1.875
KWK99787	7.869	7.879	1.359	1.500	8.375	1.750
KWK99799	7.933	7.943	1.000	1.250	8.375	1.750
KWK99800	7.995	8.005	1.000	1.250	8.375	1.750

Part Number	Shaft	O.D.	Width	Seal Number	Description
PSK-1	1.250	1.756	-	SR2 (2) SW2 5683 5864	(KIT) ++ ++
5000	1.763	2.416	0.563	** -	
5001	1.875	2.565	0.563	-	
5008	4.642	5.756	0.750	455053	Contains * JX847 Wear Sleeve
*5010	4.750	6.006	0.750	** 476621H	Contains * J1135 Wear Sleeve
5015	3.010	8.250	0.571	** 8369S	Contains * G48 Gasket & * JV495 Wear Sleeve & (2) * G523 Gasket
5026	6.000	6.757	0.750	** 336665H	Contains * J1141 Wear Sleeve
5028	3.930	5.381	0.875	** 9586	Contains * JV1511A Wear Sleeve
5033	4.834	5.756	0.710	** 3492	Contains * JX2162 Wear Sleeve
5039	5.991	6.757	0.500	** 4165V	Contains * JV2088 Wear Sleeve
5045	2.496	3.758	0.625	** 200851%	Contains * JV1582 Wear Sleeve
5065	3.994	5.005	0.625	** 455134H	Contains * J1129 Wear Sleeve
5066	2.377	3.505	0.937	** 3894V	Contains * JX1920 Wear Sleeve Seal & Sleeve
5068	-	-	-	-	(Split Seal)
5071	1.500	2.570	0.550	** 200861%	Contains * JV933 Wear Sleeve
5072	2.625	3.480	0.380	-	
5073	-	-	-	-	Contains (2) G753 Gasket
5075	4.500	6.259	0.862	** 9588	Contains * JV1513 Wear Sleeve
5076	3.937	5.678	0.875	** 9586	Contains * JV1511 Wear Sleeve
5077	4.375	6.259	0.843	** 9587	Contains * JV1512 Wear Sleeve
5079	3.110	5.750	0.375	** 7896S	
*5082	5.180	6.507	0.750	** 456986H	Contains * J2037 Wear Sleeve
5084	3.750	4.756	0.625	-	
5089	3.937	5.509	0.597	** 2155	Contains * JV1511 Wear Sleeve
5092	-	3.030	0.325	-	(Split Seal)
5095	3.438	4.012	0.410	-	(Rope Type)
5100	3.112	4.633	0.920	** 9583	Contains * JV1508 Wear Sleeve
5106	-	-	-	-	Split Seal
5108	-	4.200	0.222	-	(Split Seal)
5111	-	-	-	-	(Split Seal)
5112	-	-	-	-	(Split Seal)
5116	-	4.000	0.187	-	(Split Seal)
5117	3.438	4.313	0.188	-	(Split Seal)
5118	-	-	-	-	(Split Seal)
5120	3.125	4.130	0.625	** 415566N	Contains * J1122 Wear Sleeve
5146	5.500	6.631	0.875	** 415487	Contains * JV1463 Wear Sleeve
5147	2.625	3.755	0.625	** 200919	Contains * JV1517 Wear Sleeve
5160	2.250	3.256	0.625	** 412038	Contains * J1113 Wear Sleeve & * JV1836 Wear Sleeve
5161	2.000	3.376	0.625	** 410972	Contains * J1109 Wear Sleeve & * JV1837 Wear Sleeve
5163	2.835	3.425	0.230	-	
5164	6.875	8.633	0.825	** 3123 ** 3124	
5166	1.250	2.254	0.750	** 410169	Contains * JV1873 Wear Sleeve
5167	3.625	4.756	0.875	** 475379	Contains * JV1874 Wear Sleeve
5168	1.062	2.129	0.625	** 413293	Contains * JV1872 Wear Sleeve
5169	3.250	4.254	0.750	** 476028	Contains * JV1875 Wear Sleeve
5170	4.062	5.506	0.875	** 415039	Contains * JV1473 Wear Sleeve

Part Number	Shaft	O.D.	Width	Seal Number	Description
*5172	2.000	5.880	0.458	** 6959	Contains * K251 Wiper & * G895A Gasket
5175	9.265	11.385	0.990	** 455871V	Contains * JV829 Wear Sleeve
5185	3.125	8.250	0.571	-	
5188	2.000	3.376	0.625	** 410972N	Contains * J1109 Wear Sleeve & * JV1837 Wear Sleeve
5189	2.250	3.256	0.625	** 412038N	Contains * J1113 Wear Sleeve & * JV1836 Wear Sleeve
5199	5.000	6.131	0.875	** 8971H	Contains * JX1831 Wear Sleeve
5200	1.502	2.381	0.940	** 9613S	Contains * RP 356 Bushing (Seal & Bushing Kit)
5201	1.500	2.378	1.500	** 470059	Contains * RP 605 Bushing (Seal & Bushing Kit)
5202	1.500	2.378	1.500	** 7692S	Contains * RP 605 Bushing (Seal & Bushing Kit)
5203	1.689	2.850	2.120	** 7300S	Contains * RP 661 Bushing (Seal & Bushing Kit)
5204	1.376	2.254	1.370	** 7495S	Contains * RP 691 Bushing (Seal & Bushing Kit)
5205	1.688	2.687	1.240	** 7038SA	Contains RP 717 Bushing (Seal & Bushing Kit)
5206	1.688	2.850	2.120	** 7300S	Contains * RP 546 Bushing (Seal & Bushing Kit)
5207	1.566	2.515	1.370	** 8935S	Contains * RP 553 Bushing (Seal & Bushing Kit)
5208	1.887	1.998	1.000	** 9449	Contains RP775 Bushing (Seal & Bushing Kit)
5227	9.375	11.383	0.825	** 3502 ** 3503	
5228	5.875	7.008	0.875	** 456055V	Contains * JX1002 Wear Sleeve
5229	4.993	6.131	0.750	** 416172	Contains * J1137 Wear Sleeve
5273	2.991	3.637	0.385	** 100202T	(Tefbnf)
5274	3.740	4.540	0.492	** 100203T	Contains 733215 Gasket (Tefbn
5276	7.369	9.010	0.875	** 415551	Contains * JV1190 Wear Sleeve
5277	3.625	4.256	0.390	** 100204T	(Tefbnf)
5278	3.750	4.506	0.362	** 100205T	(Tefbnf)
5279	3.583	4.375	0.394	** 100052T	Contains 731414 Gasket (Tefbn f)
5287	3.465	4.266	0.437	** 100239T	Contains 732079 Gasket & * 733419 Gasket & 734280 Gasket (Tefbnf)
5290	2.988	3.740	1.165	** -	
5302	1.750	3.376	0.667	** 8398	Contains * K259 Wiper
5313	3.010	8.250	0.571	** 8369S	Contains * K282 Wiper & (2) * G523 Gasket
5327	3.500	6.625	0.531	** 6245S	Contains (2) * G35 Gasket
5329	2.000	4.562	0.562	6465B	Contains (2) G33 Gasket
5330	2.000	4.562	0.562	** 6469	Contains (2) * G34 Gasket
5331	1.562	2.506	0.500	** 450185	Contains * G199 Gasket
5332	2.187	3.194	0.437	450354	Contains * G25 Gasket
5336	1.875	2.762	0.500	** 410283	Contains * G736 Gasket
5346	1.062	1.507	0.250	** 340210	Contains (2) * 666215 'O' Ring & * 666232 'O' Ring & * 666334 'O' Ring
5347	3.562	4.630	0.700	** 8480	Contains * JV1170 Wear Sleeve
5361	1.875	3.130	0.625	** 450310N	Contains * J1107 Wear Sleeve
5364	1.766	3.005	0.875	** 451139	Contains * JX825 Wear Sleeve
5373	3.250	4.254	0.625	** 416294N	Contains * J1123 Wear Sleeve
5376	4.000	5.004	0.625	** 413134N	Contains * J1129 Wear Sleeve
5377	4.750	6.256	0.750	** 415068N	Contains * J1135 Wear Sleeve
5381	3.250	5.004	0.625	** 415025	Contains * J1123 Wear Sleeve
5382	3.250	4.254	0.625	** 415613	Contains * J1123 Wear Sleeve
5383	5.625	6.632	1.000	455447	Contains * J1355 Wear Sleeve
5384	2.531	6.125	0.500	** 7154S	Contains & G41 Gasket
5388	1.875	2.690	0.625	450360	Contains * J1107 Wear Sleeve
5390	-	6.600	0.430	-	Contains (2) * G214 Gasket & (2) * G594 Gasket
5397	2.121	3.350	0.500	** 9434 ** 482435	

Part Number	Shaft	O.D.	Width	Seal Number	Description
5399	2.812	4.504	1.000	** 415356	Contains * JV1427 Wear Sleeve
5401	2.500	6.125	0.435	** 7512S	Contains (2) * G41 Gasket & * G43 Gasket & * JV1304 Wear Sleeve
5403	2.860	6.562	0.571	** 6479	Contains J493 Wear Sleeve
5405	3.125	7.500	0.625	** 6480	Contains * G49 Gasket & * K282 Wiper
5406	2.562	8.250	1.003	** 6481N	Contains * G40 Gasket & * K282 Wiper
5408	3.124	8.250	0.518	** 6477S	Contains (2) * G40 Gasket & * G42 Gasket & * J873 Wear Sleeve
5410	3.125	8.125	0.571	** 6505S	Contains * G48 Gasket & (2) * G54 Gasket & * JV495 Wear Sleeve
5414	-	5.625	0.430	-	Contains (2) * G129 Gasket & * G130 Gasket & * G131 Gasket
5419	-	6.906	0.440	-	Contains (2) * G137 Gasket
5422	5.187	6.513	1.380	** 327984	Contains * JF2280 Wear Sleeve
5424	5.179	6.513	1.380	** 327984	Contains * JF2280 Wear Sleeve
5436	6.500	8.007	0.750	914414	Contains JG2361 Wear Sleeve
5441	6.500	8.007	0.750	914411	Contains JL2361 Wear Sleeve
5443	6.500	8.007	1.000	914413	Contains JG2345 Wear Sleeve
5452	3.000	8.250	0.531	6764S	Contains * G48 Gasket & * G167 Gasket & * J495 Wear Sleeve
5453	3.625	4.879	0.585	** 485497	Contains * 633013 'O' Ring Kit
5458	1.880	2.414	0.250	** 6910S	Contains * 610101 'O' Ring
5460	4.687	5.756	1.562	** 455251H	Contains * JV729 Wear Sleeve
5461	4.687	5.756	1.562	** 75251S	Contains * J729 Wear Sleeve
5462	1.172	1.832	0.422	** 6370N	Contains * J712 Wear Sleeve
5465	3.937	5.506	0.859	** 455037	Contains * JV1362 Wear Sleeve
5471	4.812	6.316	1.250	** 6872S	Contains * JV701 Wear Sleeve
5472	4.812	7.004	1.250	** 7006S	Contains * JV701 Wear Sleeve
5473	4.812	6.505	1.125	** 6873S	Contains * JV701 Wear Sleeve
5475	3.868	5.506	0.921	** 6864S	Contains * J718 Wear Sleeve
5476	-	4.875	0.455	** -	Contains (2) * G211 Gasket
*5479	-	4.862	0.410	-	Contains (2) * G196 Gasket & (2) * G214 Gasket
5481	4.759	6.316	1.250	** 6872S	Contains * JV753 Wear Sleeve
5483	4.759	6.505	1.125	** 6873S	Contains * JV753 Wear Sleeve
5487	2.000	5.880	0.448	-	Contains (2) * G221 Gasket & * K251 Wiper
5488	2.129	2.766	0.250	** 6957	Contains * 610123 'O' Ring
5494	3.010	8.150	0.925	** 6897	Contains (2) * G40 Gasket & * K156 Wiper
5495	4.759	7.004	1.250	** 7006S	Contains * JV753 Wear Sleeve
5499	1.915	2.548	0.250	** 7020	Contains * 610105 'O' Ring
5509	3.119	4.130	0.750	** 255566H	Contains * J1401 Wear Sleeve
5518	3.119	4.756	0.875	-	
*5520	2.432	3.756	0.750	** 415244	Contains * JV1455 Wear Sleeve
5521	2.120	3.505	0.750	** 415093	Contains * JV1456 Wear Sleeve
5526	3.994	5.004	0.718	** 415134	Contains * JV1461 Wear Sleeve
5527	4.743	6.256	0.812	415068	Contains * JV1462 Wear Sleeve
5531	1.812	2.879	0.718	** 410295	Contains * JV1464 Wear Sleeve
5532	3.562	5.256	0.468	** 416670	Contains * JV1469 Wear Sleeve
5537	4.062	6.000	0.875	** 416673	Contains * JV1473 Wear Sleeve
5538	6.875	8.382	0.750	** 416674	Contains * JV1474 Wear Sleeve
5550	1.438	2.192	0.480	** 9249	Contains * 623017 'O' Ring
*5551	3.500	5.256	0.718	** 416335	Contains * JV1494 Wear Sleeve
5563	3.937	5.506	0.859	** 6864S	Contains * JV1362 Wear Sleeve
5567	2.430	3.031	0.380	-	
5573	1.915	2.548	0.250	** 7020	Contains * 610145 'O' Ring
5575	4.687	7.635	0.359	** 6701	Contains JV608 Wear Sleeve

Part Number	Shaft	O.D.	Width	Seal Number	Description
*5576	-	5.700	0.415	-	Contains (2) * G427 Gasket
5578	3.125	4.130	1.000	** 485500N	Contains * K179 Wiper
5581	4.000	5.004	0.937	** 7390	Contains * JV943 Wear Sleeve
5584	2.750	3.881	1.000	** 415479N	Contains * K198 Wiper
5588	3.375	4.380	0.812	** 8130	Contains * JV976 Wear Sleeve
5589	2.129	2.766	0.250	** 6957	Contains * 666151 'O' Ring
5591	-	6.240	0.400	-	Contains (2) * G462 Gasket & (2) * G463 Gasket
5592	1.493	2.507	0.700	** 8097	Contains * JV970 Wear Sleeve
5593	3.250	4.572	0.750	** 200870	Contains * JV980 Wear Sleeve
5594	1.875	4.812	0.312	** 7105S	Contains (2) * G196 Gasket & (2) * G456 Gasket
5596	-	4.875	0.410	-	Contains (2) * G196 Gasket & (2) * G456 Gasket
5599	1.875	2.627	0.843	** 470455	Contains * J990 Wear Sleeve
5601	2.875	3.756	0.625	** 476023N	Contains * JV1120 Wear Sleeve
5602	2.375	3.433	1.000	** 473274N	Contains * JV1802 Wear Sleeve
5603	2.375	4.943	1.000	** 3136N	Contains * JV1802 Wear Sleeve
5604	2.125	3.072	0.433	** 3948	Contains * JV2019 Wear Sleeve
5609	3.250	4.008	0.866	-	
5613	6.079	7.336	0.750	** 2628	Contains * K458 Wiper & * J1842 Wear Sleeve
5615	7.908	9.508	0.960	** 3624 ** 3776S	
5624	5.000	6.131	0.875	** 456557	Contains * JX1831 Wear Sleeve
5625	4.646	5.756	0.625	** 485138	Contains * JX1386 Wear Sleeve
5629	3.000	4.008	0.625	** 457034	Contains * J1121 Wear Sleeve
5632	9.057	10.719	1.000	** 3689	Contains * J1984 Wear Sleeve
*5634	6.204	7.336	0.812	** 3807	Contains * J1825 Wear Sleeve
5637	6.079	7.336	0.600	** 2628	Contains * J1895 Wear Sleeve
5643	4.875	6.006	0.715	** 3782	Contains * J1606 Wear Sleeve
5645	5.998	6.757	0.675	** 4165V	Contains * J2051 Wear Sleeve
5649	3.562	5.125	0.875	** 9584	Contains * JV1509 Wear Sleeve
5650	-	5.700	0.415	-	
5657	3.000	4.008	0.687	** 457034	Contains * JX1747 Wear Sleeve
5665	4.841	5.756	0.750	** 3492V	Contains JX1967 Wear Sleeve
5666	2.340	3.355	0.650	** 3501V	Contains * JX1966 Wear Sleeve
5667	3.865	6.102	0.975	** 4269	Contains * J2058 Wear Sleeve
5682	-	-	-	-	
5685	-	-	-	-	
5686	-	-	-	-	(Kit)
5690	-	-	-	-	(Repair Kit)
5694	-	-	-	** 1884 ** 4899	(Kit)
5695	2.010	2.965	0.318	722111 ** SK1 ** SK2	Contains *SK3 Wear Sleeve (Kit)
5696	2.047	2.964	0.315	** 1993 ** 4898	(Kit)
5697	1.875	3.150	0.315	722110 4051	Contains * AS232 'O' Ring
5698	2.420	3.558	0.336	4185	Contains * AS043 'O' Ring
5699	1.875	2.808	0.433	4310	Contains * AS232 'O' Ring
5700	-	-	-	-	(Kit)
5722	5.000	6.006	0.717	** 947090	Contains * JL2370 Wear Sleeve

Shaft	Bore	O.D.	Width	Part Number	Style	Matl	Shaft	Bore	O.D.	Width	Part Number	Style	Matl
6	16	16.28	7	61607XX_	350	S	14	25	25.22	7	710116_	320	N
6	22	22.28	7	62207XX_	350	S	14	26	26.23	7	142607XX_	320	S
7	16	16.28	7	71607XX_	320	S	14	27	27.20	7	142707XX_	320	S
7	22	22.28	7	72207XX_	350	S	14	28	28.23	6	142806XX_	350	S
8	14	14.20	4	81404XX_	350	S	14	30	30.20	7	143007XX_	320	S
8	16	16.20	6	220860_	350	S	14	32	32.20	7	143207XX_	320	S
8	16	16.23	7	81607XX_	350	S	14	35	35.22	7	143507XX_	350	S
8	18	18.20	5	81805XX_	350	S	15	20	20.10	5	710346_	490	S
8	18	18.20	7	220818_	320	S	15	24	24.20	7	2027_	350	S
8	18	18.20	7	81807XX_	320	S	15	24	24.23	7	152407XX_	350	S
8	22	22.28	7	82207XX_	320	S	15	25	25.20	5	152505XX_	320	S
8	22	22.20	7	82207XX_	320	S	15	25	25.25	6	221510_	320	N
8	24	24.28	7	82407XX_	350	S	15	25	25.20	7	152507XX_	350	S
9	18	18.20	7	91807XX_	350	S	15	26	26.23	7	152607XX_	350	S
9	18	18.20	7	220918_	350	S	15	28	28.20	7	152807XX_	320	S
9	22	22.20	7	92207XX_	350	S	15	30	30.23	7	221540_	350	S
9	24	24.28	7	92407XX_	350	S	15	30	30.23	7	153007XX_	350	S
9	26	26.28	7	92607XX_	350	S	15	32	32.20	7	153207XX_	350	S
10	19	19.23	7	221040_	350	S	15	32	32.20	7	153207XX_	350	S
10	19	19.20	7	101907XX_	350	S	15	32	32.22	8	153208XX_	350	S
10	22	22.28	7	102207XX_	320	S	15	35	35.23	7	153507XX_	350	S
10	24	24.23	7	102407XX_	350	S	15	37	37.20	6	153706XX_	320	S
10	25	25.28	7	102507XX_	320	S	15	40	40.20	7	154007XX_	320	S
10	26	26.23	7	102607XX_	320	S	16	22	22.20	4	162204XX_	320	S
11	17	17.25	4	111704XX_	320	S	16	24	24.20	6	162406XX_	320	S
11	22	22.28	7	112207XX_	350	S	16	24	24.20	7	162407XX_	320	S
11	22	22.23	7	221122_	350	S	16	25	25.20	5	162405XX_	350	S
11	26	26.28	7	112607XX_	350	S	16	26	26.20	7	162607XX_	320	S
12	19	19.20	5	121905XX_	320	S	16	27	27.20	14	221607_	#	N
12	20	20.28	5	122005XX_	320	S	16	28	28.22	7	221610_	320	N
12	22	22.25	7	122207XX_	350	S	16	28	28.23	7	162807XX_	350	S
12	22	22.25	7	221207_	350	S	16	28	28.20	7	162807XX_	350	S
12	22	22.23	7	221208_	350	V	16	30	30.23	7	221620_	350	S
12	24	24.23	7	122407XX_	320	S	16	30	30.23	7	163007XX_	350	S
12	25	25.20	4.50	12X25045XX_	320	S	16	32	32.28	7	163207XX_	320	S
12	25	25.25	7	122507XX_	480	S	16	35	35.23	7	163507XX_	350	S
12	26	26.20	7	122607XX_	320	S	16	38	38.20	7	163807XX_	320	S
12	28	28.20	7	122807XX_	350	S	16	40	40.20	7	164007XX_	320	S
12	30	30.20	7	123007XX_	350	S	17	25	25.15	5	710362_	490	S
12	32	32.20	7	123207XX_	350	S	17	27	27.20	7	172707XX_	320	S
12	35	35.20	7	123507XX_	320	S	17	28	28.23	7	172807XX_	350	S
13	22	22.20	6	710348_	320	S	17	28	28.22	7	221710_	350	S
13	22	22.20	6	132206XX_	320	S	17	30	30.23	7	173007XX_	350	S
13	26	26.20	7	132607XX_	320	S	17	30	30.23	7	221720_	470	S
13	28	28.20	7	132807XX_	320	S	17	32	32.22	7	173207XX_	350	S
13	30	30.20	7	133007XX_	320	S	17	32	32.23	7	221730_	350	S
14	24	24.23	6	221410_	350	S	17	34	34.14	7.90	710251_	470	N
14	24	24.23	7	142407XX_	350	S	17	35	35.18	7	173507XX_	350	S
14	24	24.17	12.70	2004_	#	S	17	35	35.23	7	221735_	350	S
14	25	25.23	5	142505XX_	320	S	17	35	35.20	8	173508XX_	350	S

Shaft	Bore	O.D.	Width	Part Number	Style	Matl	Shaft	Bore	O.D.	Width	Part Number	Style	Matl
17	37	37.20	7	173707XX_	320	S	20	40	40.23	7	222050_	350	S
17	38	38.20	7	173807XX_	320	S	20	40	40.23	10	204010XX_	350	S
17	40	40.23	7	174007XX_	350	S	20	42	42.25	7	204207XX_	350	S
17	47	47.20	7	174707XX_	350	S	20	42	42.15	10	204210XX_	320	S
17	47	47.20	8	174708XX_	320	S	20	47	47.22	7	204707XX_	350	S
17	30	30.23	7	710344_	320	S	20	47	47.22	7	222060_	350	S
17.50	27.50	27.74	7	710299_	660	N	20	47	47.22	8.50	710342_→	320	S
18	23	23.24	4	710297_	340	S	20	52	52.20	7	205207XX_	350	S
18	28	28.22	6	1015_	350	S	21	35	35.20	7	213507XX_	320	S
18	28	28.22	6	1015N_	350	S	21	35	35.20	8	213508XX_	320	S
18	28	28.28	6	182806XX_	350	S	22	32	32.23	7	223207XX_	350	S
18	30	30.10	6.70	3816_	2710	S	22	32	32.23	7	222210_	350	S
18	30	30.23	7	183007XX_	350	S	22	35	35.23	7	223507XX_	350	S
18	30	30.23	8	221820_	320	S	22	35	35.23	7	222220_	320	S
18	32	32.23	7	221830_	350	S	22	36	36.20	7	223607XX_	320	S
18	32	32.23	7	710156_	320	S	22	37	37.23	7	223707XX_	350	S
18	32	32.20	7	183207XX_	350	S	22	38	38.20	7	223807XX_	350	S
18	32	32.22	8	183208XX_	350	S	22	38	38.20	8	223808XX_	320	S
18	34	34.24	7	710412_	320	S	22	38	38.20	8	222238_	320	S
18	35	35.18	7	183507XX_	320	S	22	40	40.23	7	224007XX_	350	S
18	37	37.20	8	183708XX_	320	S	22	40	40.16	7	1963_	350	N
18	38	38.20	7	183807XX_	320	S	22	40	40.23	7	222240_	350	S
18	40	40.22	7	184007XX_	350	S	22	40	40.20	8	224008XX_	350	S
19	27	27.20	6	192706XX_	350	S	22	40	40.23	9	222242_	320	N
19	30	30.23	5	221920_	320	S	22	42	42.20	7	224207XX_	320	S
19	30	30.20	7	193007XX_	320	S	22	42	42.20	10	224210XX_	350	S
19	32	32.20	7	193207XX_	350	S	22	45	45.23	7	224507XX_	350	S
19	32	32.20	8	193208XX_	320	S	22	45	45.24	8	222267_←	320	H
19	32	32.23	8	221922_	320	S	22	47	47.23	7	224707XX_	350	S
19	35	35.23	8	710445_	350	S	23	31.80	32.03	5.50	710254_	340	S
19	35	35.23	10	193510XX_	350	S	23	34	34.24	8	222330_←	320	N
19	35	35.23	10	710273_	350	S	24	35	35.23	7	222410_	350	S
19	36	36.23	6.50	221925_	350	S	24	35	35.23	7	243507XX_	350	S
19	38	38.23	7	710154_	320	S	24	37	37.23	7	243707XX_	350	S
19	40	40.23	10	194010XX_	350	S	24	38	38.20	7	243807XX_	320	S
19	47	47.20	7	194707XX_	320	S	24	40	40.23	7	222430_	350	S
20	26	26.24	4	710249_	970	S	24	40	40.23	7	244007XX_	350	S
20	28	28.20	6	202806XX_	320	S	24	42	42.20	7	244207XX_	320	S
20	30	30.28	7	203007XX_	350	S	24	42	42.25	10	244210XX_	320	S
20	30	30.23	7	222025_	350	S	24	47	47.23	7	244707XX_	350	S
20	32	32.23	7	203207XX_	350	S	24	52	52.20	7	245207XX_	320	S
20	32	32.23	7	222020_	350	S	25	35	35.20	6	253506XX_	320	S
20	35	35.23	5.50	222030_→	320	S	25	35	35.25	7	253506XX_	320	S
20	35	35.23	7	203507XX_	350	S	25	35	35.13	7	222510_	350	S
20	36	36.20	7	203607XX_	320	S	25	35	35.25	7	712007_	480	V
20	36	36.22	7	222036_	320	V	25	36	36.23	7	253607XX_	320	S
20	37	37.20	7	203707XX_	320	S	25	36	36.22	8	253608XX_	350	S
20	37	37.20	8	203708XX_	320	S	25	37	37.20	7	253707XX_	320	S
20	38	38.20	7	203807XX_	320	S	25	38	38.23	7	253807XX_	350	S
20	40	40.23	7	204007XX_	350	S	25	38	38.23	7	222535_→	320	S

METRIC - SIZE

Shaft	Bore	O.D.	Width	Part Number	Style	Matl	Shaft	Bore	O.D.	Width	Part Number	Style	Matl
25	40	40.22	7	254007XX_	350	S	28	47	47.22	8	222860_→	320	N
25	40	40.23	7	222540_	470	S	28	48	48.20	8	284808XX_	320	S
25	40	40.23	8	710316_→	320	S	28	52	52.23	7	285207XX_	350	S
25	42	42.20	6	254206XX_	350	S	29	45	45.24	8	320595_←	320	S
25	42	42.20	8	254208XX_	320	S	30	40	40.23	7	304007XX_	350	S
25	42	42.28	10	254210XX_	350	S	30	40	40.23	7	1129_	350	S
25	45	45.23	8	254508XX_	350	S	30	40	40.23	7	223005_	480	S
25	46	46.20	7	254607XX_	320	S	30	42	42.20	7	304207XX_	350	S
25	47	47.23	7	254707XX_	350	S	30	42	42.24	7	1970_	350	S
25	47	47.22	7	222560_	350	S	30	42	42.24	7	223010_→	320	S
25	48	48.20	8	254808XX_	320	S	30	44	44.28	7	304407XX_	250	S
25	50	50.28	10	255010XX_	350	S	30	44	44.22	9	223012_→	320	N
25	52	52.27	7	255207XX_	350	S	30	45	45.22	5	304505XX_	320	S
25	52	52.20	8	255208XX_	350	S	30	45	45.24	6	223014_	320	S
25	52	52.20	10	255210XX_	350	S	30	45	45.20	8	304508XX_	320	S
25	62	62.28	10	256210XX_	320	S	30	45	45.24	8	1981_→	350	N
25	62	62.28	10	222580_	320	S	30	45	45.20	8	710359_	#	S
26	37	37.20	7	263707XX_	320	S	30	45	45.20	15	2016_	#	S
26	38	38.20	5	263805XX_	320	S	30	46	46.20	7	304607XX_	320	S
26	40	40.20	7	264007XX_	320	S	30	46	46.23	7	223018_→	320	S
26	42	42.20	7	264207XX_	320	S	30	46	46.23	8	712001_→	320	N
26	42	42.14	8	223606_	480	S	30	47	47.25	7	304707XX_	350	S
26	42	42.23	10	264210XX_	350	S	30	47	47.22	7	223020_	350	S
26	47	47.23	7	264707XX_	350	S	30	48	48.28	8	304808XX_	350	S
26	48	48.24	7	222655_→	320	S	30	48	48.24	8	714619_	350	S
26	48	48.23	7	264807XX_	320	S	30	50	50.23	7	305007XX_	350	S
26	52	52.20	8	265208XX_	320	S	30	50	50.20	8	305008XX_	480	S
27	37	37.15	7	273707XX_	350	S	30	50	50.24	9	223050_←	320	S
27	42	42.23	10	274210XX_	350	S	30	52	52.23	7	305207XX_	350	S
27	43	43.23	7	710157_→	320	S	30	52	52.27	7	223035_	350	S
27	43	43.20	8	274308XX_	320	S	30	55	55.28	10	305510XX_	350	S
27	43	43.23	9	1990_→	320	N	30	56	56.20	8	305608XX_	350	S
27	43	43.20	9	222743_←	320	H	30	58	58.09	9.50	3907_	570	N
27	45	45.25	8	274508XX_	350	S	30	62	62.28	7	306207XX_	350	S
27	45	45.24	9	222745_←	320	N	30	72	72.27	10	307210XX_	350	S
27	47	47.23	10	274710XX_	350	S	31	44	44.20	8	314408XX_	320	S
27	52	52.20	8	275208XX_	350	S	31	46	46.23	8	1121_←	320	V
28	38	38.23	7	283807XX_	350	S	31	46	46.23	8	710332_←	320	N
28	38	38.23	10	710347_←	320	S	32	40	40.15	5	223210_	340	S
28	40	40.26	7	284007XX_	350	S	32	42	42.20	7	324207XX_	350	S
28	40	40.23	7	222820_	330	S	32	42	42.20	8	710282_	320	S
28	40	40.20	8	284008XX_	320	S	32	42	42.20	8	324208XX_	320	S
28	40	40.23	8	710325_→	320	S	32	42	42.20	10	223215_←	320	S
28	41	41.27	7	222830_	320	N	32	43	43.23	7	710370_	320	S
28	42	42.23	8	284208XX_	350	S	32	43	43.20	7	324307XX_	320	S
28	42	42.24	8	712008_←	320	H	32	44	44.22	6	223220_→	320	N
28	44	44.23	6	284406XX_	320	N	32	45	45.24	7	223230_	320	S
28	44	44.22	6	222835_	320	N	32	45	45.23	7	324507XX_	320	S
28	45	45.20	8	284508XX_	320	S	32	46	46.23	6	223235_→	320	N
28	47	47.22	7	284707XX_	350	S	32	46	46.23	6	324606XX_	320	S

Shaft	Bore	O.D.	Width	Part Number	Style	Matl	Shaft	Bore	O.D.	Width	Part Number	Style	Matl
32	47	47.22	6	710310_→	320	N	34	65	65.10	12	710151_	470	S
32	47	47.23	7	324707XX_	350	S	35	44	44.15	7	710383_	470	S
32	47	47.22	8	3476_→	320	N	35	45	45.15	7	354507XX_	350	S
32	47	47.22	8	3476S_→	320	N	35	47	47.40	7	1172_→	320	H
32	48	48.24	7	223240_→	400	N	35	47	47.40	7	1172S_→	320	H
32	48	48.24	7	710327_→	320	S	35	47	47.22	7	223510_	350	S
32	48	48.20	8	324808XX_	350	S	35	47	47.23	7	354707XX_	350	S
32	48	48.24	10	710317_←	320	S	35	48	48.24	8	714436_	320	S
32	50	50.24	8	223250_→	320	S	35	48	48.20	8	354808XX_	320	S
32	50	50.14	8	710162_	480	V	35	48	48.24	10	1108_→	320	V
32	50	50.14	8	710164_	480	V	35	48	48.13	13	1215_←	#	N
32	50	50.24	8	710415_→	320	S	35	48	48.13	13	1215N_←	#	N
32	50	50.23	8	325008XX_	350	S	35	48	48.13	13	710051_	860	S
32	52	52.27	7	223255_	350	S	35	49	49.30	8	710178_	#	S
32	52	52.28	7	325207XX_	350	S	35	49.50	49.83	10	1940_→	320	N
32	52	52.27	11	1167_	320	N	35	50	50.29	7	1980_→	320	H
32	52	52.27	11	1167S_	320	N	35	50	50.29	7	3771_→	350	H
32	52	52.28	11	223252_←	320	N	35	50	50.20	7	355007XX_	350	S
32	53	53.29	7	223253_→	320	N	35	50	50.29	8	223520_	350	S
32	54	54.15	9	2008_	#	S	35	50	50.29	8	710329_←	320	H
32	54	54.15	9	2008S_	#	S	35	50	50.34	8	713771_→	350	V
32	54	54.23	10	325410XX_	320	S	35	50	50.24	8	355008XX_	350	S
32	56	56.28	10	325610XX_	350	S	35	50	50.24	11	710324_←	320	S
32	58	58.20	8	325808XX_	320	S	35	50	50.29	11.50	710111_←	#	N
32	60	60.20	8	326008XX_	320	S	35	52	52.15	7	223535_	330	S
32	60	60.20	10	326010XX_	480	S	35	52	52.20	7	355207XX_	350	S
32	62	62.20	8	326208XX_	320	S	35	52	52.27	8	3655_→	320	N
32	72	72.20	8	327208XX_	320	S	35	52	52.27	8	3655S_→	320	N
33	44	44.15	8	710070_	470	S	35	52	52.13	8	4052R_↔	#	N
33	47	47.22	7	223340_→	320	S	35	52	52.35	8	713655_	320	N
33	49	49.23	8	710236_→	320	N	35	52	52.13	8	355208XX_	330	S
33	50	50.24	7	710328_	350	S	35	52	52.25	10	1170_	320	S
33	50	50.25	12	335012XX_	320	S	35	52	52.25	10	1170S_	320	S
33	50	50.25	12	1168_←	320	S	35	54	54.15	8	710217_	#	S
33	52	52.25	6	335206XX_	320	S	35	54	54.20	8	710331_←	320	V
33	56	56.29	13	710132_	400	N	35	54	54.20	8	355408XX_	350	S
33	59	59.28	11	710124_	400	N	35	54	54.15	9	710199_↔	#	N
34	44	44.23	8	223400_	320	N	35	55	55.27	8	223540_	320	N
34	45	45.20	8	344508XX_	320	S	35	55	55.27	8	223542_	320	N
34	48	48.24	7.50	710416_	350	S	35	55	55.17	8	473823_	470	S
34	48	48.24	8	223420_→	320	N	35	55	55.10	8	355508XX_	470	S
34	52	52.28	8	345208XX_	320	S	35	55	55.23	11	355511XX_	320	S
34	53	53.28	8	223440_	320	N	35	56	56.29	8	2007_→	#	S
34	53	53.29	8	710418_	320	N	35	56	56.29	8	2007N_→	#	S
34	54	54.28	9	710110_↔	400	N	35	56	56.29	8	2007S_→	#	S
34	54	54.20	9	345409XX_	350	S	35	56	56.29	8	710314_←	400	N
34	55	55.20	9	345509XX_	320	S	35	56	56.29	8	710315_→	400	S
34	62	62.28	10	710422_	350	S	35	56	56.20	8	355608XX_	350	S
34	62	62.18	10	346210XX_	350	S	35	56	56.20	9	710396_↔	400	S
34	63	63.27	9	710109_↔	400	N	35	56	56.29	10	223543_	320	S

Shaft	Bore	O.D.	Width	Part Number	Style	Matl	Shaft	Bore	O.D.	Width	Part Number	Style	Matl
35	56	56.29	10	710218_	#	V	36	65	65.20	8	710057_	480	S
35	56	56.27	10	355610XX_	320	S	36	68	68.28	10	366810XX_	350	S
35	58	58.27	10	223550_	450	S	37	62	62.26	9.50	4989_	#	S
35	58	58.28	10	355810XX_	350	S	37	50	50.29	6	223750_→	320	N
35	60	60.27	8	710424_	350	S	37	50.50	50.70	6	710355_→	320	N
35	60	60.23	10	356010XX_	350	S	37	52	52.15	6	710149_	#	S
35	60	60.15	12	710201_	470	S	37	52	52.28	8	375208XX_	350	S
35	62	62.28	7	223552_	320	S	37	56	56.29	9	710259_↔	320	V
35	62	62.28	7	356207XX_	350	S	37	58	58.10	10	710353_→	660	S
35	62	62.28	9	4901_	400	N	37	62	62.23	10	710228_	400	S
35	62	62.28	9	223553_→	400	N	37	78	78.30	12	239134_	#	S
35	62	62.20	10	356210XX_	350	S	38	50	50.25	6	223802_→	320	N
35	63	63.17	10	223554_	#	S	38	50	50.25	7	385007XX_	350	S
35	64	64.13	8	223555_	470	N	38	50	50.28	8	223800_→	320	N
35	64	64.13	8	356408XX_	470	N	38	50	50.29	8	223801_	320	S
35	65	65.20	8	356508XX_	320	S	38	52	52.27	6	1196_	470	S
35	65	65.20	10	356510XX_	320	S	38	52	52.15	6	3357_	2830	S
35	65	65.28	12	710335_	320	S	38	52	52.15	6.30	710309_	#	S
35	67	67.27	12	1173_	320	N	38	52	52.20	7	385207XX_	320	S
35	68	68.28	9	1140_→	320	N	38	52	52.27	7	1174_	320	S
35	68	68.16	9	223580_→	400	S	38	52	52.27	7	1174S_	320	S
35	68	68.20	9	710336_←	400	N	38	52	52.27	7	1966_→	350	Y
35	70	70.20	8	357008XX_	320	S	38	52	52.25	8.50	38X52085XX_	320	S
35	72	72.29	10	710360_	350	S	38	53	53.29	7	1120_←	320	V
35	72	72.28	10	357210XX_	350	S	38	53	53.29	7	1120S_←	320	V
35	76	76.28	9	1136_←	300	N	38	53	53.20	8	385308XX_	320	S
35	76	76.28	9	1136S_←	300	N	38	54	54.18	7	385407XX_	480	S
35	76	76.28	9	1147_→	320	N	38	54	54.28	8	239146_←	480	S
35	80	80.20	8	358008XX_	320	S	38	54	54.18	10	385410XX_	320	S
36	44	44.22	5	710252_	320	S	38	55	55.23	7	385507XX_	350	N
36	46	46.15	9	710343_	330	S	38	55	55.27	9	223830_	350	N
36	47	47.20	7	364707XX_	350	S	38	55	55.27	9	223831_→	320	N
36	47	47.22	7	223601_	350	S	38	56	56.28	10	385610XX_	350	S
36	49	49.23	7	223602_→	320	N	38	57	47.00	7	223805_	250	S
36	50	50.08	7	365007XX_	470	S	38	58	58.11	8	385808XX_	470	S
36	50	50.14	7	223605_	470	S	38	58	58.17	8	223840_	470	S
36	50	50.29	8	710341_←	320	S	38	58	58.27	10	710139_	#	N
36	52	52.20	7	365207XX_	350	S	38	58	58.27	11	1175_	320	S
36	52	52.20	10	223608_←	320	S	38	59	59.28	9	1038_→	320	N
36	54	54.28	7.50	223610_	350	S	38	60	60.20	8	386008XX_	320	S
36	54	54.20	8	365408XX_	350	S	38	60	60.35	10	386010XX_	350	S
36	55	55.09	6.50	2003_	470	S	38	60	60.27	10	223843_	350	S
36	55	55.09	6.50	2003N_	470	S	38	62	62.28	7	386207XX_	350	S
36	56	56.25	10	365610XX_	350	S	38	63	63.17	10	2009_	#	N
36	58	58.25	8	365808XX_	470	S	38	63	63.17	10	2009S_	#	N
36	58	58.23	12	365812XX_	350	S	38	65	65.20	8	386508XX_	320	S
36	60	60.20	7	366007XX_	320	S	38	65	65.27	12	1176_→	#	N
36	60	60.20	8	1965_	480	V	38	65	65.27	12	1176S_→	#	N
36	62	62.28	7	366207XX_	320	S	38	68	68.20	8	386808XX_	320	S
36	64	64.16	11	710152_	#	S	38	68	68.20	10	386810XX_	320	S

Shaft	Bore	O.D.	Width	Part Number	Style	Matl	Shaft	Bore	O.D.	Width	Part Number	Style	Matl
38	70	70.20	10	387010XX_	350	S	40	60	60.20	10	406010XX_	350	S
38	72	72.20	10	387210XX_	350	S	40	62	62.20	7	406207XX_	350	S
38	74	74.20	8	387408XX_	320	S	40	62	62.25	8	406208XX_	320	S
38	74	74.20	11	387411XX_	320	N	40	62	62.20	9	710131_	#	S
38	74	74.17	11	1177_	320	N	40	62	62.28	11	224045_	320	S
39	50.40	50.57	8.50	1126_	250	S	40	62	62.25	11.50	406212XX_	350	S
39	50.40	50.57	8.50	1126S_	250	S	40	63	63.27	8	224063_→	320	N
39	52	52.15	6.30	1205_	470	S	40	64	64.16	12	1216_	740	N
39	52	52.15	6.30	1205N_	470	S	40	64	64.16	12	1216N_	740	N
39	52	52.15	6.30	710338_	660	S	40	64	64.16	12	710326_	660	S
39	57	57.28	11	710123_	400	N	40	65	65.15	10	224100_	350	S
39	57	57.28	15.50	710122_	400	N	40	65	65.28	10	406510XX_	350	S
39	59	59.28	17	710118_	400	S	40	66	66.27	8	224063_→	400	N
40	58.70	58.98	9.50	1873_→	350	S	40	68	68.80	8	406808XX_	350	S
40	56	56.29	8	224025_→	320	N	40	68	68.25	12	406812XX_	350	S
40	2.56	65.00	9.50	474161_	470	S	40	70	70.20	8	407008XX_	320	S
40	50	50.20	8	405008XX_	350	S	40	72	72.24	7	350572_	350	V
40	52	52.25	6	1178_	320	S	40	72	72.35	7	407207XX_	350	S
40	52	52.25	6	1178S_	320	S	40	73	73.10	12.50	710284_	#	N
40	52	52.27	6	224015_→	320	S	40	74	74.12	10	474133_	470	S
40	52	52.27	6	710308_→	320	S	40	75	75.16	12	2011_→	400	N
40	52	52.15	7	1217_	350	N	40	75	75.16	12	2011S_→	400	N
40	52	52.15	7	1962_	780	S	40	75	75.20	12	712011_	320	S
40	52	52.15	7	224010_	350	S	40	75	75.29	12	712020_←	320	N
40	52	52.27	7	224052_→	320	H	40	76	76.28	9	1036_→	400	N
40	52	52.25	7	405207XX_	350	S	40	76	76.28	9	1146_←	320	N
40	52	52.20	9	4175_	#	S	40	76	76.28	9	1146S_←	320	N
40	52	52.27	15	239201_	320	S	40	78	78.80	8	407808XX_	320	S
40	54	54.15	5.30	1213_	470	S	40	78	78.20	10	407810XX_	350	S
40	54	54.15	5.30	1213N_	470	S	40	80	80.28	10	408010XX_	350	S
40	54	54.15	5.30	1213S_	470	S	40	90	90.20	8	409008XX_	350	S
40	54	54.20	5.50	405406XX_	470	S	41	53	53.16	7	1950_	410	S
40	54	54.15	6	710311_	250	S	41	55	55.17	6	1180_	320	S
40	54	54.28	6	710444_←	320	S	41	55	55.17	6	1180S_	320	S
40	55	55.20	6.50	405506XX_	350	S	41	55	55.29	7	415507XX_	320	S
40	55	55.17	8	3392_	470	S	41	56	56.25	7	415607XX_	350	S
40	55	55.27	8	224020_→	320	S	41	56	56.16	7	1181_	350	S
40	55	55.27	8	473677_	470	S	41	59	59.28	10	710114_→	980	N
40	55	55.28	8	405508XX_	350	S	41	62	62.23	9	710220_→	320	N
40	55.50	55.65	9	710300_	#	S	41	63	63.20	9	710291_←	400	N
40	56	56.20	7	405607XX_	320	S	42	55	55.17	6	224200_	320	S
40	56	56.29	8	712551_	320	S	42	55	55.17	6	224200S_	320	S
40	56	56.29	9	224026_↔	350	V	42	55	55.17	6	224210_	350	S
40	57	57.20	10	405710XX_	320	S	42	55	55.20	7	425507XX_	320	S
40	58	58.20	8	405808XX_	350	S	42	55	55.27	8	3051_→	330	H
40	58	58.17	9	3459_↔	740	N	42	55	55.27	8	3051N_→	330	H
40	58	58.17	9	3459S_↔	740	N	42	55	55.33	8	224205_→	320	N
40	58	58.28	10	405810XX_	320	S	42	55	55.28	8	425508XX_	350	S
40	60	60.15	8	710147_	#	S	42	55	55.17	9	1214_	470	S
40	60	60.27	10	224040_	350	S	42	55	55.17	9	1214N_	470	S

Shaft	Bore	O.D.	Width	Part Number	Style	Matl	Shaft	Bore	O.D.	Width	Part Number	Style	Matl
42	56	56.34	7	3774S_→	350	H	44	60	60.27	7	224460_→	350	X
42	56	56.21	7	224220_	490	S	44	60	60.20	10	446010XX_	350	S
42	56	56.29	7	710097_	#	S	44	62	62.26	8	446208XX_↔	320	S
42	56	56.34	7	3774_→	350	H	44	62	62.28	8	224462_	320	S
42	56	56.13	7	425607XX_	320	S	44	62	62.28	10	224464_←	320	N
42	56.20	56.49	6	494117_	490	S	44	65	65.28	10	446510XX_	350	S
42	58	58.10	7	425807XX_	480	S	44	65	65.28	11	224465_→	320	S
42	58	58.17	9	224235_	480	S	44	68	68.28	8	350609_←	350	N
42	58	58.27	9.50	224215_←	320	N	44	70	70.20	8	447008XX_	320	S
42	59	59.16	7.70	710442_→	480	N	44	72	72.11	10	447210XX_	350	S
42	60	60.27	7	1953_	320	N	44	80	80.29	8.70	710115_↔	980	S
42	60	60.27	7	1953S_	320	N	45	58	58.28	7	455807XX_	350	S
42	60	60.27	7	2025_	320	V	45	59	59.28	8	710193_	320	S
42	60	60.22	7	426007XX_	320	S	45	60	60.20	7	456007XX_	350	S
42	62	62.28	7	224252_	320	S	45	60	60.27	8	224520_	350	S
42	62	62.28	7	710408_	320	N	45	60	60.20	8	456008XX_	350	S
42	62	62.27	8	426208XX_	350	S	45	60	60.25	10	456010XX_	350	S
42	62	62.28	10	224250_→	350	S	45	60	60.25	10.80	2440_	690	N
42	62	62.10	12	710403_	#	S	45	61	61.29	8	710260_←	320	S
42	63	63.27	9	710298_→	400	N	45	62	62.15	6	494122_	490	S
42	64.10	64.39	6	224254_	340	S	45	62	62.28	8	1012N_	320	S
42	65	65.15	10	224255_	470	N	45	62	62.28	8	1012S_	350	S
42	65	65.15	10	426510XX_	470	N	45	62	62.15	8	710078_	470	V
42	67	67.20	10	710286_	320	N	45	62	62.30	8	456208XX_	350	S
42	68	68.20	8	426808XX_	320	S	45	64	64.29	9	1938_	#	S
42	68	62.20	10	426810XX_	320	S	45	64	64.29	9	1939_	#	S
42	70	70.20	10	427010XX_	320	S	45	64	64.29	9	1951_	870	S
42	72	72.20	8	427208XX_	320	S	45	65	65.15	5	1992_	470	S
42	72	72.27	10	224270_	350	S	45	65	65.28	8	456508XX_	350	S
42	72	72.27	10	427210XX_	320	S	45	67	67.16	8	710289_→	320	S
42	76	76.15	12	710245_→	#	N	45	68	68.28	7	456807XX_	320	S
42	80	80.20	8	428008XX_	320	S	45	68	68.28	8.50	224560_	320	S
42	80	80.20	10	428010XX_	350	S	45	68	68.28	12	320564_→	320	V
42	90	90.27	9.50	710133_	#	N	45	68	68.20	12	710345_	320	S
42	90	90.27	11.90	710246_	#	N	45	70	70.18	10	457010XX_	320	S
43	54	54.15	6.50	224400_	250	S	45	72	72.29	7	224570_	350	S
43	54	54.15	7.50	334111_	330	S	45	72	72.28	7	457207XX_	350	S
43	55	55.27	6	2012_→	320	Y	45	72	72.20	10	457210XX_	350	S
43	55	55.27	6	2012S_→	320	Y	45	72	72.25	10	457295XX_	320	S
43	55	55.27	6	2012V_→	320	V	45	72	72.28	12	457212XX_	350	S
43	55	55.27	6	710264_→	320	Y	45	72.20	72.49	7.50	1943_	440	S
43	55	55.27	8	1183_	340	S	45	75	75.20	7	457507XX_	320	S
43	55	55.20	8	435508XX_	320	S	45	75	75.16	12	1979_→	470	N
43	58.47	58.62	7.50	710159_	#	S	45	78	78.16	11	710248_→	660	N
43	60	60.27	9	320583_→	320	S	45	80	80.28	10	458010XX_	350	S
43	62	62.18	10	224320_	470	S	45	85	85.20	10	458510XX_	350	S
43	65	65.20	8	436508XX_	320	S	45	85	85.25	13	458513XX_	450	S
43	70	70.16	9	710142_	#	S	45	98	98.17	10.50	710364_↔	#	N
43	92	92.28	12.50	710208_	#	S	46	2.73	69.40	11	710126_	#	S
44	60	60.20	7	446007XX_	320	S	46	58	58.27	7	224650_→	320	N

Shaft	Bore	O.D.	Width	Part Number	Style	Matl	Shaft	Bore	O.D.	Width	Part Number	Style	Matl
46	60	60.27	7	224660_→	320	H	49	64	64.29	6	1936_	#	S
46	65	65.20	7	466507XX_	320	S	49	70	70.28	11	710305_	320	S
46	68.50	68.63	7.50	710161_	2810	S	49	70	70.28	11	710305S_	320	S
46	70	70.20	8	467008XX_	320	S	49	72.20	72.49	6	710148_	970	S
46	70	70.10	8	710238_→	320	S	49	79	79.10	-	224979_	470	N
47	62	62.20	8	476208XX_	320	S	49	100	100.20	8	710374_	#	S
47	64	64.29	6	1937_	#	S	50	2.57	67.00	5.50	710226_	320	S
47	65	65.20	8	476508XX_	320	S	50	2.62	66.50	13	474134_	470	S
47	66	66.10	6	710215_	660	S	50	60	60.27	6	710192_	320	S
47	68	68.27	10	476810XX_	320	S	50	62	62.18	7	225005_	320	S
47	68	68.27	10	1187S_	320	S	50	62	62.28	7	506207XX_	350	S
47	70	70.20	10	477010XX_	320	S	50	62	62.13	9	225008_	470	S
47	72	72.16	8	224772_	480	S	50	64.10	64.39	6.50	710098_	710	S
47	72.20	72.49	6	710337_	340	S	50	65	65.28	8	710354_→	320	N
47	80	80.16	12.70	710150_	#	S	50	65	65.28	8	506508XX_	320	S
47	84	84.28	9.50	710143_	#	S	50	65	65.15	9	1209_	350	S
48	60	60.15	9	710356_→	470	S	50	65	65.15	9	1209S_	350	S
48	62	62.28	6	1188_	340	S	50	65	65.15	9	3743_	660	S
48	62	62.28	6	1188S_	340	S	50	65	65.15	9	225010_	470	S
48	62	62.28	6	710322_	340	S	50	67	67.20	9	710357_	470	S
48	62	62.28	7	224810_	320	N	50	67	67.29	11	1974_	970	S
48	62	62.28	8	224820_	320	S	50	68	68.10	6.50	710194_	320	S
48	62	62.10	8	486208XX_	350	S	50	68	68.28	8	1948_	350	S
48	62	62.28	9	1956_	#	S	50	68	68.28	8	506808XX_	350	S
48	62	62.28	9	1956S_	#	S	50	68	68.28	9	225020_→	320	V
48	62	62.10	9	710320_	480	S	50	68	68.28	9	710420_→	320	S
48	63	63.09	9	486309XX_	470	S	50	70	70.10	7	413818_	410	S
48	64	64.20	10	710167_	#	S	50	70	70.20	8	507008XX_	320	S
48	65	65.15	8.10	1973_	250	S	50	70	70.13	9	1960_	470	S
48	65	65.28	9	224865_	320	S	50	70	70.20	9	507009XX_	320	S
48	65	65.30	10	486510XX_	320	S	50	70	70.20	10	710173_	#	N
48	65	65.15	24.50	4528N_	660	N	50	70	70.20	14	710135_	#	S
48	68	68.27	10	486810XX_	320	N	50	72	72.29	8	225030_	350	S
48	68	68.28	11	224835_→	320	N	50	72	72.28	8	507208XX_	350	S
48	68	68.28	11	224840_→	320	S	50	72	72.29	9	225035_	320	S
48	70	70.20	8	487008XX_	350	S	50	72	72.20	10	710398_	#	S
48	70	70.28	9	1994_	320	S	50	72	72.29	12	225040_→	320	S
48	70	70.20	9	710255_	#	S	50	73	73.15	12	450474_	450	S
48	70	70.28	9	712010_→	320	H	50	75	75.20	7	507507XX_	320	S
48	70	70.28	9	487009XX_	350	S	50	75	75.28	12	507512XX_	320	S
48	70	70.28	12	710313_→	320	S	50	80	80.29	8	225050_	350	S
48	72	72.31	7	487207XX_	320	S	50	80	80.28	8	508008XX_	350	S
48	72	72.29	8.50	224850_	350	S	50	80	80.30	16.50	710112_↔	#	N
48	72	72.29	8.50	224872_	320	S	50	82	82.18	8	225082_	#	S
48	73	73.10	7	224870_	470	S	50	85	85.20	8	508508XX_	320	S
48	74	74.27	10	224874_	320	S	50	86	86.30	13	710117_	400	N
48	75	75.20	10	487510XX_	320	S	50	90	90.20	8	509008XX_	320	S
48	80	80.20	8	488008XX_	320	S	50	90	90.28	10	509010XX_	350	S
48	90	90.20	10	489010XX_	350	S	51	77.50	77.65	14	1941_	470	S
49	62	62.15	8.50	4904_	660	S	51	62	62.13	7	710407_	330	S

METRIC - SIZE

Shaft	Bore	O.D.	Width	Part Number	Style	Matl	Shaft	Bore	O.D.	Width	Part Number	Style	Matl
51	63	63.17	6	494123_	490	S	55	68	68.28	8	225500_	320	S
51	63	63.17	6	710323_	490	S	55	70	70.27	8	557008XX_	350	S
51	65	65.15	7	225110_	470	S	55	70	70.13	9	3723_	660	S
51	65	65.10	7	516507XX_	470	S	55	70	70.13	9	225505_	320	S
52	62	62.28	5.50	710253_	#	S	55	72	72.25	8	557208XX_	350	S
52	63	63.23	8	1975_	320	S	55	72	72.24	8	225530_	350	S
52	63	63.23	8	1975S_	320	S	55	72	72.29	10	225535_	320	S
52	65	65.30	9	526509XX_	350	S	55	74	74.17	6	1207_	490	S
52	65	65.15	9	1955_	350	S	55	74	74.17	6	1207N_	490	S
52	65	65.28	9	225208_	320	S	55	75	75.20	7	55X1007X_	320	S
52	66	66.12	7.50	4898_	660	S	55	75	75.20	8	557508XX_	350	S
52	66	66.27	9	225210_	350	N	55	75	75.35	10	557510XX_	350	S
52	67	67.29	7	1883_	320	S	55	75	75.24	10	225545_	350	S
52	68	68.15	6.50	225220_	350	S	55	78	78.28	10	557810XX_	350	S
52	68	68.15	6.50	710292_	#	S	55	80	80.28	8	558008XX_	350	S
52	68	68.15	7.50	1884_	320	S	55	82	82.17	10	1958_	350	S
52	68	68.15	7.50	710064_	#	S	55	82	82.30	12	558212XX_	350	S
52	68	68.28	7.60	4990_	2810	S	55	85	85.31	10	558510XX_	350	S
52	68	68.28	8	526808XX_	350	S	55	88	88.20	8	558808XX_↔	320	S
52	68	68.15	8	710190_	480	V	55	90	90.28	13	559013XX_	350	S
52	68	68.20	13	710312_	320	S	55	100	100.30	12.70	55X10013X_	450	S
52	69	69.28	10	526910XX_	350	S	56	66	66.20	17	710382_	#	S
52	70	70.20	8	527008XX_	320	S	56	68	68.15	4.50	1932_	490	S
52	70	70.16	8	225225_	470	S	56	68	68.15	4.50	1932S_	490	S
52	70	70.28	8.50	710187_→	320	N	56	68	68.12	10	566810XX_	480	N
52	72	72.29	7.50	225540_	320	S	56	70	70.20	8	567008XX_	350	S
52	72	72.29	7.70	225230_	350	S	56	72	72.20	7	567207XX_	320	S
52	72	72.20	8	527208XX_	350	S	56	72	72.14	9	225650_	320	S
52	72	72.29	8	710242_→	320	N	56	72	72.16	10.90	710069_	#	S
52	75	75.11	7.50	225275_	660	S	56	72	72.40	11.50	56X72115XX_	350	S
52	75	75.28	12	527512XX_	350	S	56	72	72.27	12.50	225227_	#	S
52	78	78.28	9	225278_	350	N	56	73	73.15	7.50	1993_	470	S
52	78.40	78.49	9.80	710107_	#	S	56	73	73.15	7.50	225673_	#	S
52	80	80.28	10	528010XX_↔	320	S	56	74	74.17	8.50	710176_	870	S
52	82	82.20	8	528208XX_	320	S	56	74.20	74.37	6.50	710125_	#	S
52	85	85.20	8	528507XX_	320	S	56	75	75.13	6.60	4899_	660	S
53	2.69	68.20	7	710175_	320	S	56	75	75.33	7	225775_	#	S
54	65	65.20	8	546508XX_	320	S	56	75	75.20	7	567507XX_	320	S
54	65	65.15	13	2002_	470	S	56	76	76.15	4.90	710108_	660	S
54	66	66.17	7.50	225410_	#	S	56	78	78.28	7.50	225678_	#	S
54	69	69.23	7.50	710239_	400	N	56	80	80.28	8	568008XX_	320	S
54	72	72.25	10	225420_	320	S	56	82	82.20	8	568208XX_	320	S
54	72	72.25	10	547210XX_	320	S	56	85	85.28	8	568508XX_	350	S
54	73	73.20	8	547308XX_	320	S	56	88	88.20	8	568808XX_	320	S
54	75.50	75.78	18	710073_	#	S	56	90	90.20	8	569008XX_	320	S
54	82	82.30	8	225450_	320	S	57	67	67.29	6	1984_	250	S
54	82	82.35	10	548210XX_	320	S	57	72	72.14	8.40	1964_	470	S
54	85	85.28	10	548510XX_	320	S	57	77	77.20	8	710129_	#	S
55	68	68.15	6.50	710127_	#	S	57	79	79.25	13.70	710072_	#	S
55	68	68.28	8	556808XX_	320	S	57	79	79.25	13.70	710074_	#	S

Shaft	Bore	O.D.	Width	Part Number	Style	Matl	Shaft	Bore	O.D.	Width	Part Number	Style	Matl
57	81	81.18	8	1928_	470	S	63	85	85.28	10	638510XX_	320	S
57	85	85.20	13	578513XX_	320	S	63	90	90.17	7	1935_	470	S
58	72	72.28	8	587208XX_	350	S	63	90	90.14	10	639010XX_	320	S
58	74	74.27	10	710271_←	320	S	64	77	77.20	8	710130_	#	S
58	74	74.12	13	225874_	1010	N	64	80	80.21	8	226480_→	330	H
58	75	75.29	9	225875_	320	S	64	80	80.28	8	648008XX_	320	S
58	75	75.16	9	710400_	470	S	65	80	80.28	8	658008XX_	320	S
58	75	75.28	11	587511XX_	350	S	65	81	81.28	7	226510_→	320	Y
58	76	76.23	7.80	710230_	#	S	65	82	82.17	7	710094_	660	S
58	77	77.27	8.50	225877_	350	N	65	84	84.28	9	712005_→	320	H
58	78	78.28	10	710144_←	#	S	65	85	85.20	8	658508XX_	350	S
58	80	80.28	8	588008XX_	350	S	65	85	85.27	10	658510XX_	350	S
58	80	80.29	8	225880_	350	S	65	85	85.22	10	226520_	350	S
58	85	85.25	13	588513XX_	320	S	65	85	85.17	10	710373_	470	S
58	88	88.20	8	588808XX_	320	S	65	88	88.20	8	658808XX_	350	S
58	90	90.28	10	589010XX_	350	S	65	88	88.20	10	658810XX_	320	S
59	75	75.11	10	710168_	470	S	65	88	88.20	12	710367_→	400	S
59	100	100.28	10	710121_	#	N	65	90	90.20	7	659007XX_	320	S
60	72	72.16	7.50	710379_	470	S	65	90	90.28	10	659010XX_	350	S
60	72	72.28	8	607208XX_	350	S	65	90	90.27	10	226530_	350	S
60	75	75.16	5.80	710093_	#	S	65	90	90.20	13	659013XX_	350	S
60	75	75.28	8	607508XX_	350	S	65	100	100.30	7	65X10007XX_	320	S
60	75	75.29	9	226015_←	320	N	65	100	100.28	10	65X10010XX_	350	S
60	78	78.28	9	226018_	350	N	66	80	80.11	9	226610_	410	N
60	80	80.20	8	608008XX_	350	S	66	85	85.17	8	710092_	410	S
60	80	80.29	8	1039S_	350	S	68	82	82.20	7	688207XX_	350	S
60	82	82.20	7	608207XX_	320	S	68	84	84.28	8.50	710234_←	320	N
60	82	82.30	12	608212XX_	350	S	68	85	85.20	8	688508XX_	350	S
60	82	82.27	12	2001_←	320	S	68	86	86.28	8	710334_←	320	N
60	82	82.20	12	710390_→	320	N	68	88	88.29	8	710446_→	350	S
60	82	82.27	12	712006_←	320	H	68	90	90.20	7	689007XX_	320	S
60	85	85.28	8	608508XX_	350	S	68	90	90.32	10	689010XX_	350	S
60	85	85.20	12	608512XX_	320	S	68	90	90.17	12	710440_	470	S
60	86	86.18	7	710182_	660	S	68	95	95.20	10	689510XX_	350	S
60	90	90.25	8	609008XX_	320	S	68	100	100.20	10	68X10010XX_	350	S
60	90	90.27	10	609010XX_	350	S	68	100	100.28	13	68X10013XX_	350	S
60	90	90.17	14	1985_	480	S	70	85	85.28	8	708508XX_	350	S
60	90	90.17	14	1985S_	480	S	70	87	87.27	8.50	1021_←	320	V
60	95	95.20	8	609508XX_	320	S	70	87	87.27	8.50	1021V_←	320	V
60	100	100.20	10	60X10010XX_↔	320	N	70	88	88.25	8	708808XX_	480	S
60	103	103.18	12	710276_	400	N	70	88	88.29	12	227020_←	320	H
60	110	110.20	8	60X11008XX_	320	S	70	88	88.25	12	708812XX_	320	S
61	76	76.28	7	226150_	#	S	70	90	90.20	7	709007XX_	320	S
62	78	78.16	9.50	710213_	2810	S	70	90	90.32	10	227040_←	350	H
62	80	80.20	9	628009XX_	320	S	70	90	90.32	10	709010XX_	350	S
62	80	80.28	10	628010XX_	350	S	70	92	92.28	8.50	227045_←	470	H
62	85	85.17	8	226285_	410	S	70	92	92.20	12	709212XX_	320	S
62	85	85.13	8	628508XX_	410	S	70	95	95.28	10	709510XX_	350	S
62	90	90.28	10	629010XX_	350	S	70	95	95.28	13	709513XX_	350	S
62	100	100.30	7	62X10007XX_	320	S	70	100	100.20	10	70X10010XX_	320	S

Shaft	Bore	O.D.	Width	Part Number	Style	Matl	Shaft	Bore	O.D.	Width	Part Number	Style	Matl
70	100	100.28	13	70X10013XX_	350	S	80	120	120.20	10	80X12010XX_	320	S
70	105	105.30	7	70X10507XX_	320	S	80	120	120.28	13	80X12013XX_	320	S
70	105	105.20	13	70X10513XX_	350	S	82	105	105.25	13	82X10513XX_	250	S
70	110	110.20	10	70X11010XX_	350	S	82	105	105.32	13	228480_←	320	H
70	112	112.17	14	710339_	250	S	83	100	100.28	9	228250_←	320	H
72	88	88.25	7	1986_	480	S	84	104	104.27	11	228410_←	320	V
72	88	88.25	7	1986S_	480	S	85	105	105.28	10	85X10510XX_	320	S
72	90	90.20	10	729010XX_	350	S	85	105	105.28	10	716102_←	320	H
72	95	95.28	10	729510XX_	350	S	85	105	105.28	13	85X10513XX_	320	S
72	96	96.29	9	227235_←	320	H	85	110	110.20	10	85X11010XX_	350	S
72	100	100.20	10	72X10010XX_	350	S	85	110	110.28	12	85X11012XX_	350	S
72	100	100.31	12	72X10012XX_↔	320	S	85	110	110.29	12	228520_	350	S
74	98	98.27	12	227410_→	320	H	85	115	115.00	13	85X11513XX_	350	S
75	83	87.00	4	710240_	#	S	85	120	120.28	12	85X12012XX_	320	S
75	90	90.20	8	759008XX_	320	S	85	125	125.20	12	85X12512XX_	320	S
75	90	90.25	10	759010XX_	320	S	85	130	130.15	12.70	85X13013XX_	480	S
75	95	95.28	10	227530_	350	S	86	103	103.28	10	710235_←	320	V
75	95	95.28	10	716445_	350	V	86	104	104.37	11	710232_	320	V
75	95	95.28	10	759510XX_	350	S	87	100	100.28	8	228700_←	320	H
75	100	100.28	10	227540_	320	S	88	106	106.27	8.50	710188_←	320	V
75	100	100.20	10	75X10010XX_	320	S	88	108	108.28	11	3772_←	350	H
75	100	100.27	12	75X10012XX_	320	S	88	110	110.28	12	88X11012XX_	350	S
75	100	100.28	13	227550_←	320	H	89	105	105.28	10	710189_←	470	V
75	100	100.18	13	710384_	250	S	90	104	104.27	11	710237_←	320	V
75	105	105.27	13	75X10513XX_	320	S	90	110	110.29	9	229005_←	320	V
75	110	110.20	12	75X11012XX_	320	S	90	110	110.29	9	229006_←	320	H
75	115	115.30	12	75X11512XX_	350	S	90	110	110.29	9	229010_←	320	H
75	120	120.20	10	75X12010XX_	320	S	90	110	110.20	12	90X11012XX_	350	S
76	92	92.28	10	4307V_←	320	V	90	115	115.20	12	90X11512XX_	320	S
76	92	92.28	10	327995_←	320	V	90	120	120.28	12	90X12012XX_	320	S
76	93	93.30	10	1019_←	320	H	90	125	125.70	7	90X12507XX_	320	S
76	93	93.30	10	1019S_←	320	H	90	125	125.30	13	90X12513XX_	320	S
76	98	98.27	12	227610_→	320	H	90	145	145.20	14	90X14514XX_	320	S
76	102	102.20	9.50	710375_	#	S	91	110	110.29	8.50	229210_←	320	V
78	100	100.27	10	78X10010XX_	350	S	91	111	111.28	10	710056_←	470	V
78	105	105.20	10	78X10510XX_	320	S	92	120	120.24	13	92X12013XX_	350	S
78	115	115.20	10	78X11510XX_	320	S	93	114	114.30	13	710288_←	320	S
80	96	96.29	9	228005_←	320	V	93	154	154.20	8	710266_	#	S
80	98	98.27	10	228008_←	320	X	95	110	110.20	10	95X11010XX_	320	S
80	100	100.28	10	228009_←	320	H	95	110	110.29	11	717005_←	320	S
80	100	100.28	10	228012_	350	S	95	113	113.10	10	710352_	470	V
80	100	100.20	10	80X10010XX_	350	S	95	115	115.28	12	95X11512XX_	350	S
80	100	100.28	13	228010_←	320	H	95	118	118.29	10	710060_←	320	H
80	100	100.28	13	228015_→	320	H	95	120	120.28	12	95X12012XX_	350	S
80	105	105.20	10	80X10510XX_	320	S	95	125	125.28	12	95X12512XX_	350	S
80	105	105.28	13	228020_	320	S	95	130	130.28	12	95X13012XX_	350	S
80	105	105.27	13	80X10513XX_	480	S	98	120	120.20	13	98X12013XX_	350	S
80	110	110.29	10	228030_	350	S	100	114	114.20	12	710410_	470	S
80	110	110.28	10	80X11010XX_	320	S	100	120	120.30	10	10X012010XX_	350	S
80	110	110.28	12	80X11012XX_	350	S	100	120	120.27	11	231004_	320	H

Shaft	Bore	O.D.	Width	Part Number	Style	Matl	Shaft	Bore	O.D.	Width	Part Number	Style	Matl
100	120	120.28	12	10X012012XX_	350	S	140	160	160.27	13	14X016013XX_	350	S
100	120	120.13	12	231002_	350	S	140	170	170.30	12	14X017012XX_	320	S
100	125	125.28	12	10X012512XX_	350	S	140	170	170.21	14	710406_	470	S
100	125	125.35	12	231003_	350	S	140	170	170.43	15	14X017015XX_	350	S
100	130	130.28	12	10X013012XX_	350	S	140	180	180.30	12	14X018012XX_	350	S
100	135	135.36	10	710351_←	320	H	140	180	180.38	18	14X018018XX_	320	S
101	114	114.10	10	710371_	250	S	143	168.30	168.50	13.10	417555_	410	S
102	130	130.28	13	10X213013XX_	350	S	144	160	160.25	12	14X416012XX_	350	S
105	125	125.28	13	10X512513XX_	320	S	145	164	264.10	14	710369_	470	S
105	130	130.28	12	10X513012XX_	350	S	145	164	164.10	14	14X516414XX_	470	S
105	140	140.28	12	10X514012XX_	350	S	145	170	170.45	12	14X517012XX_	350	S
106	126	126.37	12	710366_←	320	H	145	175	175.38	15	14X517515XX_	350	S
110	130	130.35	10	2261_←	470	V	145	180	180.28	12	14X518012XX_	350	S
110	130	130.28	12	11X013012XX_	350	S	145	180	180.28	12	14X518012XX_	350	S
110	135	135.30	13	11X013513XX_	320	S	148	170	170.28	15	14X817015XX_	350	S
110	140	140.28	12	11X014012XX_	320	S	148	170	170.28	15	14X817015XX_	350	S
110	140	140.23	13	11X014013XX_	450	S	150	180	180.35	12	15X018012XX_	350	S
110	145	145.30	13	11X014513XX_	350	S	150	180	180.35	15	15X018015XX_	350	S
110	150	150.28	15	11X015015XX_	350	S	155	180	180.23	15	15X518015XX_	320	S
112	140	140.32	13	11X2140013XX_	350	S	160	185	185.35	10	16X018510XX_	350	S
114	140	140.28	13	11X414013XX_	350	S	160	190	190.35	15	16X019015XX_	350	S
115	135	135.36	10	710258_←	320	V	160	200	200.20	12	16X020012XX_	320	S
115	140	140.28	12	11X514012XX_	350	S	160	200	200.20	15	16X020015XX_	320	S
115	145	145.30	13	11X514513XX_	350	S	170	200	200.35	15	17X020015XX_	350	S
115	145	145.20	14	11X514514XX_	320	S	170	210	210.20	15	17X021015XX_	320	S
115	150	150.28	12	11X515012XX_	350	S	175	200	200.35	15	17X520015XX_	320	S
115	156	156.10	15.50	710372_	#	S	180	210	210.35	15	18X021015XX_	350	S
120	140	140.21	12	717004_	480	S	185	210	210.35	13	18X512013XX_	350	S
120	140	140.28	13	12X014013XX_	350	S	190	220	220.35	16	19X022016XX_	350	S
120	145	145.28	12	12X014512XX_	350	S	190	230	230.20	16	19X023016XX_	320	S
120	150	150.28	12	12X015012XX_	350	S	200	230	230.35	15	20X023015XX_	450	S
120	160	160.28	12	12X016012XX_	350	S	210	240	240.35	15	21X024015XX_	350	S
124	170	-	14.50	710381_	#	S	210	250	250.20	15	21X025015XX_	320	S
125	150	150.28	12	12X515012XX_	320	S	220	250	250.35	15	22X025015XX_	350	S
125	150	150.37	12	231250_	350	S	230	260	260.35	15	23X026015XX_	350	S
125	155	155.20	12	12X515512XX_	320	S	240	270	270.35	15	24X027015XX_	350	S
125	160	160.28	12	12X516012XX_	350	S	240	280	280.20	16	24X028016XX_	320	S
125	170	170.20	15	12X517015XX_	320	S	280	320	320.45	20	28X032020XX_	320	S
128	150	150.28	15	12X815015XX_	350	S	300	340	340.45	20	30X034020XX_	320	S
130	150	150.10	10	13X015010XX_	470	S							
130	150	150.22	10	710380_	470	S							
130	160	160.28	12	13X016012XX_	350	S							
130	160	160.20	15	13X016015XX_	320	S							
130	170	170.30	12	13X017012XX_	350	S							
130	170	170.28	15	13X017015XX_	350	S							
135	160	160.38	13	13X516013XX_	350	S							
135	170	170.38	12	13X517012XX_	350	S							
138	152	152.10	12	13X815212XX_	470	S							
138	152	152.20	12	710368_	470	S							
140	160	160.20	12	14X016012XX_	320	S							

METRIC - SIZE

Part Number	Style	Matl	Shaft	Bore	O.D.	Width	Part Number	Style	Matl	Shaft	Bore	O.D.	Width
1012N	320	S	45	62	62.28	8	1207	490	S	55	74	74.17	6
1012S	350	S	45	62	62.28	8	1207N	490	S	55	74	74.17	6
1015	350	S	18	28	28.22	6	1209	350	S	50	65	65.15	9
1015N	350	S	18	28	28.22	6	1209S	350	S	50	65	65.15	9
1019←	320	H	76	93	93.30	10	1213	470	S	40	54	54.15	5.30
1019S←	320	H	76	93	93.30	10	1213N	470	S	40	54	54.15	5.30
1021←	320	V	70	87	87.27	8.50	1213S	470	S	40	54	54.15	5.30
1021V←	320	V	70	87	87.27	8.50	1214	470	S	42	55	55.17	9
1036→	400	N	40	76	76.28	9	1214N	470	S	42	55	55.17	9
1038→	320	N	38	59	59.28	9	1215←	#	N	35	48	48.13	13
1039S	350	S	60	80	80.29	8	1215N←	#	N	35	48	48.13	13
1108→	320	V	35	48	48.24	10	1216	740	N	40	64	64.16	12
1120←	320	V	38	53	53.29	7	1216N	740	N	40	64	64.16	12
1120S←	320	V	38	53	53.29	7	1217	350	N	40	52	52.15	7
1121←	320	V	31	46	46.23	8	1873→	350	S	40	58.70	58.98	9.50
1126	250	S	39	50.40	50.57	8.50	1883	320	S	52	67	67.29	7
1126S	250	S	39	50.40	50.57	8.50	1884	320	S	52	68	68.15	7.50
1129	350	S	30	40	40.23	7	1928	470	S	57	81	81.18	8
1136←	300	N	35	76	76.28	9	1932	490	S	56	68	68.15	4.50
1136S←	300	N	35	76	76.28	9	1932S	490	S	56	68	68.15	4.50
1140→	320	N	35	68	68.28	9	1935	470	S	63	90	90.17	7
1146←	320	N	40	76	76.28	9	1936	#	S	49	64	64.29	6
1146S←	320	N	40	76	76.28	9	1937	#	S	47	64	64.29	6
1147→	320	N	35	76	76.28	9	1938	#	S	45	64	64.29	9
1167	320	N	32	52	52.27	11	1939	#	S	45	64	64.29	9
1167S	320	N	32	52	52.27	11	1940→	320	N	35	49.50	49.83	10
1168←	320	S	33	50	50.25	12	1941	470	S	51	77.50	77.65	14
1170	320	S	35	52	52.25	10	1943	440	S	45	72.20	72.49	7.50
1170S	320	S	35	52	52.25	10	1948	350	S	50	68	68.28	8
1172→	320	H	35	47	47.40	7	1950	410	S	41	53	53.16	7
1172S→	320	H	35	47	47.40	7	1951	870	S	45	64	64.29	9
1173	320	N	35	67	67.27	12	1953	320	N	42	60	60.27	7
1174	320	S	38	52	52.27	7	1953S	320	N	42	60	60.27	7
1174S	320	S	38	52	52.27	7	1955	350	S	52	65	65.15	9
1175	320	S	38	58	58.27	11	1956	#	S	48	62	62.28	9
1176→	#	N	38	65	65.27	12	1956S	#	S	48	62	62.28	9
1176S→	#	N	38	65	65.27	12	1958	350	S	55	82	82.17	10
1177	320	N	38	74	74.17	11	1960	470	S	50	70	70.13	9
1178	320	S	40	52	52.25	6	1962	780	S	40	52	52.15	7
1178S	320	S	40	52	52.25	6	1963	350	N	22	40	40.16	7
1180	320	S	41	55	55.17	6	1964	470	S	57	72	72.14	8.40
1180S	320	S	41	55	55.17	6	1965	480	V	36	60	60.20	8
1181	350	S	41	56	56.16	7	1966→	350	Y	38	52	52.27	7
1183	340	S	43	55	55.27	8	1970	350	S	30	42	42.24	7
1187S	320	S	47	68	68.27	10	1973	250	S	48	65	65.15	8.10
1188	340	S	48	62	62.28	6	1974	970	S	50	67	67.29	11
1188S	340	S	48	62	62.28	6	1975	320	S	52	63	63.23	8
1196	470	S	38	52	52.27	6	1975S	320	S	52	63	63.23	8
1205	470	S	39	52	52.15	6.30	1979→	470	N	45	75	75.16	12
1205N	470	S	39	52	52.15	6.30	1980→	320	H	35	50	50.29	7

Part Number	Style	Matl	Shaft	Bore	O.D.	Width	Part Number	Style	Matl	Shaft	Bore	O.D.	Width
1981 →	350	N	30	45	45.24	8	4052R ↔	#	N	35	52	52.13	8
1984	250	S	57	67	67.29	6	4175	#	S	40	52	52.20	9
1985	480	S	60	90	90.17	14	4307V ←	320	V	76	92	92.28	10
1985S	480	S	60	90	90.17	14	4528N	660	N	48	65	65.15	24.50
1986	480	S	72	88	88.25	7	4898	660	S	52	66	66.12	7.50
1986S	480	S	72	88	88.25	7	4899	660	S	56	75	75.13	6.60
1990 →	320	N	27	43	43.23	9	4901	400	N	35	62	62.28	9
1992	470	S	45	65	65.15	5	4904	660	S	49	62	62.15	8.50
1993	470	S	56	73	73.15	7.50	4989	#	S	37	62	62.26	9.50
1994	320	S	48	70	70.28	9	4990	2810	S	52	68	68.28	7.60
2001 ←	320	S	60	82	82.27	12	61607XX	350	S	6	16	16.28	7
2002	470	S	54	65	65.15	13	62207XX	350	S	6	22	22.28	7
2003	470	S	36	55	55.09	6.50	71607XX	320	S	7	16	16.28	7
2003N	470	S	36	55	55.09	6.50	72207XX	350	S	7	22	22.28	7
2004	#	S	14	24	24.17	12.70	81404XX	350	S	8	14	14.20	4
2007 →	#	S	35	56	56.29	8	81607XX	350	S	8	16	16.23	7
2007N →	#	S	35	56	56.29	8	81805XX	350	S	8	18	18.20	5
2007S →	#	S	35	56	56.29	8	81807XX	320	S	8	18	18.20	7
2008	#	S	32	54	54.15	9	82207XX	320	S	8	22	22.28	7
2008S	#	S	32	54	54.15	9	82207XX	320	S	8	22	22.20	7
2009	#	N	38	63	63.17	10	82407XX	350	S	8	24	24.28	7
2009S	#	N	38	63	63.17	10	91807XX	350	S	9	18	18.20	7
2011 →	400	N	40	75	75.16	12	92207XX	350	S	9	22	22.20	7
2011S →	400	N	40	75	75.16	12	92407XX	350	S	9	24	24.28	7
2012 →	320	Y	43	55	55.27	6	92607XX	350	S	9	26	26.28	7
2012S →	320	Y	43	55	55.27	6	101907XX	350	S	10	19	19.20	7
2012V →	320	V	43	55	55.27	6	102207XX	320	S	10	22	22.28	7
2016	#	S	30	45	45.20	15	102407XX	350	S	10	24	24.23	7
2025	320	V	42	60	60.27	7	102507XX	320	S	10	25	25.28	7
2027	350	S	15	24	24.20	7	102607XX	320	S	10	26	26.23	7
2261 ←	470	V	110	130	130.35	10	111704XX	320	S	11	17	17.25	4
2440	690	N	45	60	60.25	10.80	112207XX	350	S	11	22	22.28	7
3051 →	330	H	42	55	55.27	8	112607XX	350	S	11	26	26.28	7
3051N →	330	H	42	55	55.27	8	121905XX	320	S	12	19	19.20	5
3357	2830	S	38	52	52.15	6	122005XX	320	S	12	20	20.28	5
3392	470	S	40	55	55.17	8	122207XX	350	S	12	22	22.25	7
3459 ↔	740	N	40	58	58.17	9	122407XX	320	S	12	24	24.23	7
3459S ↔	740	N	40	58	58.17	9	122507XX	480	S	12	25	25.25	7
3476 →	320	N	32	47	47.22	8	122607XX	320	S	12	26	26.20	7
3476S →	320	N	32	47	47.22	8	122807XX	350	S	12	28	28.20	7
3655 →	320	N	35	52	52.27	8	123007XX	350	S	12	30	30.20	7
3655S →	320	N	35	52	52.27	8	123207XX	350	S	12	32	32.20	7
3723	660	S	55	70	70.13	9	123507XX	320	S	12	35	35.20	7
3743	660	S	50	65	65.15	9	132206XX	320	S	13	22	22.20	6
3771 →	350	H	35	50	50.29	7	132607XX	320	S	13	26	26.20	7
3772 ←	350	H	88	108	108.28	11	132807XX	320	S	13	28	28.20	7
3774S →	350	H	42	56	56.34	7	133007XX	320	S	13	30	30.20	7
3774 →	350	H	42	56	56.34	7	142407XX	350	S	14	24	24.23	7
3816	2710	S	18	30	30.10	6.70	142505XX	320	S	14	25	25.23	5
3907	570	N	30	58	58.09	9.50	142607XX	320	S	14	26	26.23	7

Part Number	Style	Matl	Shaft	Bore	O.D.	Width	Part Number	Style	Matl	Shaft	Bore	O.D.	Width
142707XX	320	S	14	27	27.20	7	193207XX	350	S	19	32	32.20	7
142806XX	350	S	14	28	28.23	6	193208XX	320	S	19	32	32.20	8
143007XX	320	S	14	30	30.20	7	193510XX	350	S	19	35	35.23	10
143207XX	320	S	14	32	32.20	7	194010XX	350	S	19	40	40.23	10
143507XX	350	S	14	35	35.22	7	194707XX	320	S	19	47	47.20	7
152407XX	350	S	15	24	24.23	7	202806XX	320	S	20	28	28.20	6
152505XX	320	S	15	25	25.20	5	203007XX	350	S	20	30	30.28	7
152507XX	350	S	15	25	25.20	7	203207XX	350	S	20	32	32.23	7
152607XX	350	S	15	26	26.23	7	203507XX	350	S	20	35	35.23	7
152807XX	320	S	15	28	28.20	7	203607XX	320	S	20	36	36.20	7
153007XX	350	S	15	30	30.23	7	203707XX	320	S	20	37	37.20	7
153207XX	350	S	15	32	32.20	7	203708XX	320	S	20	37	37.20	8
153207XX	350	S	15	32	32.20	7	203807XX	320	S	20	38	38.20	7
153208XX	350	S	15	32	32.22	8	204007XX	350	S	20	40	40.23	7
153507XX	350	S	15	35	35.23	7	204010XX	350	S	20	40	40.23	10
153706XX	320	S	15	37	37.20	6	204207XX	350	S	20	42	42.25	7
154007XX	320	S	15	40	40.20	7	204210XX	320	S	20	42	42.15	10
162204XX	320	S	16	22	22.20	4	204707XX	350	S	20	47	47.22	7
162405XX	350	S	16	25	25.20	5	205207XX	350	S	20	52	52.20	7
162406XX	320	S	16	24	24.20	6	213507XX	320	S	21	35	35.20	7
162407XX	320	S	16	24	24.20	7	213508XX	320	S	21	35	35.20	8
162607XX	320	S	16	26	26.20	7	220818	320	S	8	18	18.20	7
162807XX	350	S	16	28	28.23	7	220860	350	S	8	16	16.20	6
162807XX	350	S	16	28	28.20	7	220918	350	S	9	18	18.20	7
163007XX	350	S	16	30	30.23	7	221040	350	S	10	19	19.23	7
163207XX	320	S	16	32	32.28	7	221122	350	S	11	22	22.23	7
163507XX	350	S	16	35	35.23	7	221207	350	S	12	22	22.25	7
163807XX	320	S	16	38	38.20	7	221208	350	V	12	22	22.23	7
164007XX	320	S	16	40	40.20	7	221410	350	S	14	24	24.23	6
172707XX	320	S	17	27	27.20	7	221510	320	N	15	25	25.25	6
172807XX	350	S	17	28	28.23	7	221540	350	S	15	30	30.23	7
173007XX	350	S	17	30	30.23	7	221607	#	N	16	27	27.20	14
173207XX	350	S	17	32	32.22	7	221610	320	N	16	28	28.22	7
173507XX	350	S	17	35	35.18	7	221620	350	S	16	30	30.23	7
173508XX	350	S	17	35	35.20	8	221710	350	S	17	28	28.22	7
173707XX	320	S	17	37	37.20	7	221720	470	S	17	30	30.23	7
173807XX	320	S	17	38	38.20	7	221730	350	S	17	32	32.23	7
174007XX	350	S	17	40	40.23	7	221735	350	S	17	35	35.23	7
174707XX	350	S	17	47	47.20	7	221820	320	S	18	30	30.23	8
174708XX	320	S	17	47	47.20	8	221830	350	S	18	32	32.23	7
182806XX	350	S	18	28	28.28	6	221920	320	S	19	30	30.23	5
183007XX	350	S	18	30	30.23	7	221922	320	S	19	32	32.23	8
183207XX	350	S	18	32	32.20	7	221925	350	S	19	36	36.23	6.50
183208XX	350	S	18	32	32.22	8	222020	350	S	20	32	32.23	7
183507XX	320	S	18	35	35.18	7	222025	350	S	20	30	30.23	7
183708XX	320	S	18	37	37.20	8	222030→	320	S	20	35	35.23	5.50
183807XX	320	S	18	38	38.20	7	222036	320	V	20	36	36.22	7
184007XX	350	S	18	40	40.22	7	222050	350	S	20	40	40.23	7
192706XX	350	S	19	27	27.20	6	222060	350	S	20	47	47.22	7
193007XX	320	S	19	30	30.20	7	222210	350	S	22	32	32.23	7

Part Number	Style	Matl	Shaft	Bore	O.D.	Width	Part Number	Style	Matl	Shaft	Bore	O.D.	Width
222220	320	S	22	35	35.23	7	223550	450	S	35	58	58.27	10
222238	320	S	22	38	38.20	8	223552	320	S	35	62	62.28	7
222240	350	S	22	40	40.23	7	223553 →	400	N	35	62	62.28	9
222242	320	N	22	40	40.23	9	223554	#	S	35	63	63.17	10
222267 ←	320	H	22	45	45.24	8	223555	470	N	35	64	64.13	8
222330 ←	320	N	23	34	34.24	8	223580 →	400	S	35	68	68.16	9
222410	350	S	24	35	35.23	7	223601	350	S	36	47	47.22	7
222430	350	S	24	40	40.23	7	223602 →	320	N	36	49	49.23	7
222510	350	S	25	35	35.13	7	223605	470	S	36	50	50.14	7
222535 →	320	S	25	38	38.23	7	223606	480	S	26	42	42.14	8
222540	470	S	25	40	40.23	7	223607XX	320	S	22	36	36.20	7
222560	350	S	25	47	47.22	7	223608 ←	320	S	36	52	52.20	10
222580	320	S	25	62	62.28	10	223610	350	S	36	54	54.28	7.50
222655 →	320	S	26	48	48.24	7	223707XX	350	S	22	37	37.23	7
222743 ←	320	H	27	43	43.20	9	223750 →	320	N	37	50	50.29	6
222745 ←	320	N	27	45	45.24	9	223800 →	320	N	38	50	50.28	8
222820	330	S	28	40	40.23	7	223801	320	S	38	50	50.29	8
222830	320	N	28	41	41.27	7	223802 →	320	N	38	50	50.25	6
222835	320	N	28	44	44.22	6	223805	250	S	38	57	47.00	7
222860 →	320	N	28	47	47.22	8	223807XX	350	S	22	38	38.20	7
223005	480	S	30	40	40.23	7	223808XX	320	S	22	38	38.20	8
223010 →	320	S	30	42	42.24	7	223830	350	N	38	55	55.27	9
223012 →	320	N	30	44	44.22	9	223831 →	320	N	38	55	55.27	9
223014	320	S	30	45	45.24	6	223840	470	S	38	58	58.17	8
223018 →	320	S	30	46	46.23	7	223843	350	S	38	60	60.27	10
223020	350	S	30	47	47.22	7	224007XX	350	S	22	40	40.23	7
223035	350	S	30	52	52.27	7	224008XX	350	S	22	40	40.20	8
223050 ←	320	S	30	50	50.24	9	224010	350	S	40	52	52.15	7
223207XX	350	S	22	32	32.23	7	224015 →	320	S	40	52	52.27	6
223210	340	S	32	40	40.15	5	224020 →	320	S	40	55	55.27	8
223215 ←	320	S	32	42	42.20	10	224025 →	320	N	40	56	56.29	8
223220 →	320	N	32	44	44.22	6	224026 ↔	350	V	40	56	56.29	9
223230	320	S	32	45	45.24	7	224040	350	S	40	60	60.27	10
223235 →	320	N	32	46	46.23	6	224045	320	S	40	62	62.28	11
223240 →	400	N	32	48	48.24	7	224052 →	320	H	40	52	52.27	7
223250 →	320	S	32	50	50.24	8	224063 →	320	N	40	63	63.27	8
223252 ←	320	N	32	52	52.28	11	224066 →	400	N	40	66	66.27	8
223253 →	320	N	32	53	53.29	7	224100	350	S	40	65	65.15	10
223255	350	S	32	52	52.27	7	224200	320	S	42	55	55.17	6
223340 →	320	S	33	47	47.22	7	224200S	320	S	42	55	55.17	6
223400	320	N	34	44	44.23	8	224205 →	320	N	42	55	55.33	8
223420 →	320	N	34	48	48.24	8	224207XX	320	S	22	42	42.20	7
223440	320	N	34	53	53.28	8	224210XX	350	S	22	42	42.20	10
223507XX	350	S	22	35	35.23	7	224210	350	S	42	55	55.17	6
223510	350	S	35	47	47.22	7	224215 ←	320	N	42	58	58.27	9.50
223520	350	S	35	50	50.29	8	224220	490	S	42	56	56.21	7
223535	330	S	35	52	52.15	7	224235	480	S	42	58	58.17	9
223540	320	N	35	55	55.27	8	224250 →	350	S	42	62	62.28	10
223542	320	N	35	55	55.27	8	224252	320	S	42	62	62.28	7
223543	320	S	35	56	56.29	10	224254	340	S	42	64.10	64.39	6

Part Number	Style	Matl	Shaft	Bore	O.D.	Width	Part Number	Style	Matl	Shaft	Bore	O.D.	Width
224255	470	N	42	65	65.15	10	225535	320	S	55	72	72.29	10
224270	350	S	42	72	72.27	10	225540	320	S	52	72	72.29	7.50
224320	470	S	43	62	62.18	10	225545	350	S	55	75	75.24	10
224400	250	S	43	54	54.15	6.50	225550	320	S	56	72	72.14	9
224460→	350	X	44	60	60.27	7	225673	#	S	56	73	73.15	7.50
224462	320	S	44	62	62.28	8	225678	#	S	56	78	78.28	7.50
224464←	320	N	44	62	62.28	10	225775	#	S	56	75	75.33	7
224465→	320	S	44	65	65.28	11	225874	1010	N	58	74	74.12	13
224507XX	350	S	22	45	45.23	7	225875	320	S	58	75	75.29	9
224520	350	S	45	60	60.27	8	225877	350	N	58	77	77.27	8.50
224560	320	S	45	68	68.28	8.50	225880	350	S	58	80	80.29	8
224570	350	S	45	72	72.29	7	226015←	320	N	60	75	75.29	9
224650→	320	N	46	58	58.27	7	226018	350	N	60	78	78.28	9
224660→	320	H	46	60	60.27	7	226150	#	S	61	76	76.28	7
224707XX	350	S	22	47	47.23	7	226285	410	S	62	85	85.17	8
224772	480	S	47	72	72.16	8	226480→	330	H	64	80	80.21	8
224810	320	N	48	62	62.28	7	226510→	320	Y	65	81	81.28	7
224820	320	S	48	62	62.28	8	226520	350	S	65	85	85.22	10
224835→	320	N	48	68	68.28	11	226530	350	S	65	90	90.27	10
224840→	320	S	48	68	68.28	11	226610	410	N	66	80	80.11	9
224850	350	S	48	72	72.29	8.50	227020←	320	H	70	88	88.29	12
224865	320	S	48	65	65.28	9	227040←	350	H	70	90	90.32	10
224870	470	S	48	73	73.10	7	227045←	470	H	70	92	92.28	8.50
224872	320	S	48	72	72.29	8.50	227235←	320	H	72	96	96.29	9
224874	320	S	48	74	74.27	10	227410→	320	H	74	98	98.27	12
224979	470	N	49	79	79.10	-	227530	350	S	75	95	95.28	10
225005	320	S	50	62	62.18	7	227540	320	S	75	100	100.28	10
225008	470	S	50	62	62.13	9	227550←	320	H	75	100	100.28	13
225010	470	S	50	65	65.15	9	227610→	320	H	76	98	98.27	12
225020→	320	V	50	68	68.28	9	228005←	320	V	80	96	96.29	9
225030	350	S	50	72	72.29	8	228008←	320	X	80	98	98.27	10
225035	320	S	50	72	72.29	9	228009←	320	H	80	100	100.28	10
225040→	320	S	50	72	72.29	12	228010←	320	H	80	100	100.28	13
225050	350	S	50	80	80.29	8	228012	350	S	80	100	100.28	10
225082	#	S	50	82	82.18	8	228015→	320	H	80	100	100.28	13
225110	470	S	51	65	65.15	7	228020	320	S	80	105	105.28	13
225208	320	S	52	65	65.28	9	228030	350	S	80	110	110.29	10
225210	350	N	52	66	66.27	9	228250←	320	H	83	100	100.28	9
225220	350	S	52	68	68.15	6.50	228410←	320	V	84	104	104.27	11
225225	470	S	52	70	70.16	8	228480←	320	H	82	105	105.32	13
225227	#	S	56	72	72.27	12.50	228520	350	S	85	110	110.29	12
225230	350	S	52	72	72.29	7.70	228700←	320	H	87	100	100.28	8
225275	660	S	52	75	75.11	7.50	229005←	320	V	90	110	110.29	9
225278	350	N	52	78	78.28	9	229006←	320	H	90	110	110.29	9
225410	#	S	54	66	66.17	7.50	229010←	320	H	90	110	110.29	9
225420	320	S	54	72	72.25	10	229210←	320	V	91	110	110.29	8.50
225450	320	S	54	82	82.30	8	231002	350	S	100	120	120.13	12
225500	320	S	55	68	68.28	8	231003	350	S	100	125	125.35	12
225505	320	S	55	70	70.13	9	231004	320	H	100	120	120.27	11
225530	350	S	55	72	72.24	8	231250	350	S	125	150	150.37	12

Part Number	Style	Matl	Shaft	Bore	O.D.	Width	Part Number	Style	Matl	Shaft	Bore	O.D.	Width
239134	#	S	37	78	78.30	12	284707XX	350	S	28	47	47.22	7
239146 ←	480	S	38	54	54.28	8	284808XX	320	S	28	48	48.20	8
239201	320	S	40	52	52.27	15	285207XX	350	S	28	52	52.23	7
243507XX	350	S	24	35	35.23	7	304007XX	350	S	30	40	40.23	7
243707XX	350	S	24	37	37.23	7	304207XX	350	S	30	42	42.20	7
243807XX	320	S	24	38	38.20	7	304407XX	250	S	30	44	44.28	7
244007XX	350	S	24	40	40.23	7	304505XX	320	S	30	45	45.22	5
244207XX	320	S	24	42	42.20	7	304508XX	320	S	30	45	45.20	8
244210XX	320	S	24	42	42.25	10	304607XX	320	S	30	46	46.20	7
244707XX	350	S	24	47	47.23	7	304707XX	350	S	30	47	47.25	7
245207XX	320	S	24	52	52.20	7	304808XX	350	S	30	48	48.28	8
253506XX	320	S	25	35	35.20	6	305007XX	350	S	30	50	50.23	7
253506XX	320	S	25	35	35.25	7	305008XX	480	S	30	50	50.20	8
253607XX	320	S	25	36	36.23	7	305207XX	350	S	30	52	52.23	7
253608XX	350	S	25	36	36.22	8	305510XX	350	S	30	55	55.28	10
253707XX	320	S	25	37	37.20	7	305608XX	350	S	30	56	56.20	8
253807XX	350	S	25	38	38.23	7	306207XX	350	S	30	62	62.28	7
254007XX	350	S	25	40	40.22	7	307210XX	350	S	30	72	72.27	10
254206XX	350	S	25	42	42.20	6	314408XX	320	S	31	44	44.20	8
254208XX	320	S	25	42	42.20	8	320564 →	320	V	45	68	68.28	12
254210XX	350	S	25	42	42.28	10	320583 →	320	S	43	60	60.27	9
254508XX	350	S	25	45	45.23	8	320595 ←	320	S	29	45	45.24	8
254607XX	320	S	25	46	46.20	7	324207XX	350	S	32	42	42.20	7
254707XX	350	S	25	47	47.23	7	324208XX	320	S	32	42	42.20	8
254808XX	320	S	25	48	48.20	8	324307XX	320	S	32	43	43.20	7
255010XX	350	S	25	50	50.28	10	324507XX	320	S	32	45	45.23	7
255207XX	350	S	25	52	52.27	7	324606XX	320	S	32	46	46.23	6
255208XX	350	S	25	52	52.20	8	324707XX	350	S	32	47	47.23	7
255210XX	350	S	25	52	52.20	10	324808XX	350	S	32	48	48.20	8
256210XX	320	S	25	62	62.28	10	325008XX	350	S	32	50	50.23	8
263707XX	320	S	26	37	37.20	7	325207XX	350	S	32	52	52.28	7
263805XX	320	S	26	38	38.20	5	325410XX	320	S	32	54	54.23	10
264007XX	320	S	26	40	40.20	7	325610XX	350	S	32	56	56.28	10
264207XX	320	S	26	42	42.20	7	325808XX	320	S	32	58	58.20	8
264210XX	350	S	26	42	42.23	10	326008XX	320	S	32	60	60.20	8
264707XX	350	S	26	47	47.23	7	326010XX	480	S	32	60	60.20	10
264807XX	320	S	26	48	48.23	7	326208XX	320	S	32	62	62.20	8
265208XX	320	S	26	52	52.20	8	327208XX	320	S	32	72	72.20	8
273707XX	350	S	27	37	37.15	7	327995 ←	320	V	76	92	92.28	10
274210XX	350	S	27	42	42.23	10	334111	330	S	43	54	54.15	7.50
274308XX	320	S	27	43	43.20	8	335012XX	320	S	33	50	50.25	12
274508XX	350	S	27	45	45.25	8	335206XX	320	S	33	52	52.25	6
274710XX	350	S	27	47	47.23	10	344508XX	320	S	34	45	45.20	8
275208XX	350	S	27	52	52.20	8	345208XX	320	S	34	52	52.28	8
283807XX	350	S	28	38	38.23	7	345409XX	350	S	34	54	54.20	9
284007XX	350	S	28	40	40.26	7	345509XX	320	S	34	55	55.20	9
284008XX	320	S	28	40	40.20	8	346210XX	350	S	34	62	62.18	10
284208XX	350	S	28	42	42.23	8	350572	350	V	40	72	72.24	7
284406XX	320	N	28	44	44.23	6	350609 ←	350	N	44	68	68.28	8
284508XX	320	S	28	45	45.20	8	354507XX	350	S	35	45	45.15	7

Part Number	Style	Matl	Shaft	Bore	O.D.	Width	Part Number	Style	Matl	Shaft	Bore	O.D.	Width
354707XX	350	S	35	47	47.23	7	405008XX	350	S	40	50	50.20	8
354808XX	320	S	35	48	48.20	8	405207XX	350	S	40	52	52.25	7
355007XX	350	S	35	50	50.20	7	405406XX	470	S	40	54	54.20	5.50
355008XX	350	S	35	50	50.24	8	405506XX	350	S	40	55	55.20	6.50
355207XX	350	S	35	52	52.20	7	405508XX	350	S	40	55	55.28	8
355208XX	330	S	35	52	52.13	8	405607XX	320	S	40	56	56.20	7
355408XX	350	S	35	54	54.20	8	405710XX	320	S	40	57	57.20	10
355508XX	470	S	35	55	55.10	8	405808XX	350	S	40	58	58.20	8
355511XX	320	S	35	55	55.23	11	405810XX	320	S	40	58	58.28	10
355608XX	350	S	35	56	56.20	8	406010XX	350	S	40	60	60.20	10
355610XX	320	S	35	56	56.27	10	406207XX	350	S	40	62	62.20	7
355810XX	350	S	35	58	58.28	10	406208XX	320	S	40	62	62.25	8
356010XX	350	S	35	60	60.23	10	406212XX	350	S	40	62	62.25	11.50
356207XX	350	S	35	62	62.28	7	406510XX	350	S	40	65	65.28	10
356210XX	350	S	35	62	62.20	10	406808XX	350	S	40	68	68.80	8
356408XX	470	N	35	64	64.13	8	406812XX	350	S	40	68	68.25	12
356508XX	320	S	35	65	65.20	8	407008XX	320	S	40	70	70.20	8
356510XX	320	S	35	65	65.20	10	407207XX	350	S	40	72	72.35	7
357008XX	320	S	35	70	70.20	8	407808XX	320	S	40	78	78.80	8
357210XX	350	S	35	72	72.28	10	407810XX	350	S	40	78	78.20	10
358008XX	320	S	35	80	80.20	8	408010XX	350	S	40	80	80.28	10
364707XX	350	S	36	47	47.20	7	409008XX	350	S	40	90	90.20	8
365007XX	470	S	36	50	50.08	7	413818	410	S	50	70	70.10	7
365207XX	350	S	36	52	52.20	7	415507XX	320	S	41	55	55.29	7
365408XX	350	S	36	54	54.20	8	415607XX	350	S	41	56	56.25	7
365610XX	350	S	36	56	56.25	10	417555	410	S	143	168.30	168.50	13.10
365808XX	470	S	36	58	58.25	8	425507XX	320	S	42	55	55.20	7
365812XX	350	S	36	58	58.23	12	425508XX	350	S	42	55	55.28	8
366007XX	320	S	36	60	60.20	7	425607XX	320	S	42	56	56.13	7
366207XX	320	S	36	62	62.28	7	425807XX	480	S	42	58	58.10	7
366810XX	350	S	36	68	68.28	10	426007XX	320	S	42	60	60.22	7
375208XX	350	S	37	52	52.28	8	426208XX	350	S	42	62	62.27	8
385007XX	350	S	38	50	50.25	7	426510XX	470	N	42	65	65.15	10
385207XX	320	S	38	52	52.20	7	426808XX	320	S	42	68	68.20	8
385308XX	320	S	38	53	53.20	8	426810XX	320	S	42	68	62.20	10
385407XX	480	S	38	54	54.18	7	427010XX	320	S	42	70	70.20	10
385410XX	320	S	38	54	54.18	10	427208XX	320	S	42	72	72.20	8
385507XX	350	N	38	55	55.23	7	427210XX	320	S	42	72	72.27	10
385610XX	350	S	38	56	56.28	10	428008XX	320	S	42	80	80.20	8
385808XX	470	S	38	58	58.11	8	428010XX	350	S	42	80	80.20	10
386008XX	320	S	38	60	60.20	8	435508XX	320	S	43	55	55.20	8
386010XX	350	S	38	60	60.35	10	436508XX	320	S	43	65	65.20	8
386207XX	350	S	38	62	62.28	7	446007XX	320	S	44	60	60.20	7
386508XX	320	S	38	65	65.20	8	446010XX	350	S	44	60	60.20	10
386808XX	320	S	38	68	68.20	8	446208XX↔	320	S	44	62	62.26	8
386810XX	320	S	38	68	68.20	10	446510XX	350	S	44	65	65.28	10
387010XX	350	S	38	70	70.20	10	447008XX	320	S	44	70	70.20	8
387210XX	350	S	38	72	72.20	10	447210XX	350	S	44	72	72.11	10
387408XX	320	S	38	74	74.20	8	450474	450	S	50	73	73.15	12
387411XX	320	N	38	74	74.20	11	455807XX	350	S	45	58	58.28	7

Part Number	Style	Matl	Shaft	Bore	O.D.	Width	Part Number	Style	Matl	Shaft	Bore	O.D.	Width
456007XX	350	S	45	60	60.20	7	509010XX	350	S	50	90	90.28	10
456008XX	350	S	45	60	60.20	8	516507XX	470	S	51	65	65.10	7
456010XX	350	S	45	60	60.25	10	526509XX	350	S	52	65	65.30	9
456208XX	350	S	45	62	62.30	8	526808XX	350	S	52	68	68.28	8
456508XX	350	S	45	65	65.28	8	526910XX	350	S	52	69	69.28	10
456807XX	320	S	45	68	68.28	7	527008XX	320	S	52	70	70.20	8
457010XX	320	S	45	70	70.18	10	527208XX	350	S	52	72	72.20	8
457207XX	350	S	45	72	72.28	7	527512XX	350	S	52	75	75.28	12
457210XX	350	S	45	72	72.20	10	528010XX↔	320	S	52	80	80.28	10
457212XX	350	S	45	72	72.28	12	528208XX	320	S	52	82	82.20	8
457295XX	320	S	45	72	72.25	10	528507XX	320	S	52	85	85.20	8
457507XX	320	S	45	75	75.20	7	546508XX	320	S	54	65	65.20	8
458010XX	350	S	45	80	80.28	10	547210XX	320	S	54	72	72.25	10
458510XX	350	S	45	85	85.20	10	547308XX	320	S	54	73	73.20	8
458513XX	450	S	45	85	85.25	13	548210XX	320	S	54	82	82.35	10
466507XX	320	S	46	65	65.20	7	548510XX	320	S	54	85	85.28	10
467008XX	320	S	46	70	70.20	8	556808XX	320	S	55	68	68.28	8
473677	470	S	40	55	55.27	8	557008XX	350	S	55	70	70.27	8
473823	470	S	35	55	55.17	8	557208XX	350	S	55	72	72.25	8
474133	470	S	40	74	74.12	10	557508XX	350	S	55	75	75.20	8
474134	470	S	50	2.62	66.50	13	557510XX	350	S	55	75	75.35	10
474161	470	S	40	2.56	65.00	9.50	557810XX	350	S	55	78	78.28	10
476208XX	320	S	47	62	62.20	8	558008XX	350	S	55	80	80.28	8
476508XX	320	S	47	65	65.20	8	558212XX	350	S	55	82	82.30	12
476810XX	320	S	47	68	68.27	10	558510XX	350	S	55	85	85.31	10
477010XX	320	S	47	70	70.20	10	558808XX↔	320	S	55	88	88.20	8
486208XX	350	S	48	62	62.10	8	559013XX	350	S	55	90	90.28	13
486309XX	470	S	48	63	63.09	9	566810XX	480	N	56	68	68.12	10
486510XX	320	S	48	65	65.30	10	567008XX	350	S	56	70	70.20	8
486810XX	320	N	48	68	68.27	10	567207XX	320	S	56	72	72.20	7
487008XX	350	S	48	70	70.20	8	567507XX	320	S	56	75	75.20	7
487009XX	350	S	48	70	70.28	9	568008XX	320	S	56	80	80.28	8
487207XX	320	S	48	72	72.31	7	568208XX	320	S	56	82	82.20	8
487510XX	320	S	48	75	75.20	10	568508XX	350	S	56	85	85.28	8
488008XX	320	S	48	80	80.20	8	568808XX	320	S	56	88	88.20	8
489010XX	350	S	48	90	90.20	10	569008XX	320	S	56	90	90.20	8
494117	490	S	42	56.20	56.49	6	578513XX	320	S	57	85	85.20	13
494122	490	S	45	62	62.15	6	587208XX	350	S	58	72	72.28	8
494123	490	S	51	63	63.17	6	587511XX	350	S	58	75	75.28	11
506207XX	350	S	50	62	62.28	7	588008XX	350	S	58	80	80.28	8
506508XX	320	S	50	65	65.28	8	588513XX	320	S	58	85	85.25	13
506808XX	350	S	50	68	68.28	8	588808XX	320	S	58	88	88.20	8
507008XX	320	S	50	70	70.20	8	589010XX	350	S	58	90	90.28	10
507009XX	320	S	50	70	70.20	9	607208XX	350	S	60	72	72.28	8
507208XX	350	S	50	72	72.28	8	607508XX	350	S	60	75	75.28	8
507507XX	320	S	50	75	75.20	7	608008XX	350	S	60	80	80.20	8
507512XX	320	S	50	75	75.28	12	608207XX	320	S	60	82	82.20	7
508008XX	350	S	50	80	80.28	8	608212XX	350	S	60	82	82.30	12
508508XX	320	S	50	85	85.20	8	608508XX	350	S	60	85	85.28	8
509008XX	320	S	50	90	90.20	8	608512XX	320	S	60	85	85.20	12

Part Number	Style	Matl	Shaft	Bore	O.D.	Width	Part Number	Style	Matl	Shaft	Bore	O.D.	Width
609008XX	320	S	60	90	90.25	8	710110↔	400	N	34	54	54.28	9
609010XX	350	S	60	90	90.27	10	710111←	#	N	35	50	50.29	11.50
609508XX	320	S	60	95	95.20	8	710112↔	#	N	50	80	80.30	16.50
628009XX	320	S	62	80	80.20	9	710114→	980	N	41	59	59.28	10
628010XX	350	S	62	80	80.28	10	710115↔	980	S	44	80	80.29	8.70
628508XX	410	S	62	85	85.13	8	710116	320	N	14	25	25.22	7
629010XX	350	S	62	90	90.28	10	710117	400	N	50	86	86.30	13
638510XX	320	S	63	85	85.28	10	710118	400	S	39	59	59.28	17
639010XX	320	S	63	90	90.14	10	710121	#	N	59	100	100.28	10
648008XX	320	S	64	80	80.28	8	710122	400	N	39	57	57.28	15.50
658008XX	320	S	65	80	80.28	8	710123	400	N	39	57	57.28	11
658508XX	350	S	65	85	85.20	8	710124	400	N	33	59	59.28	11
658510XX	350	S	65	85	85.27	10	710125	#	S	56	74.20	74.37	6.50
658808XX	350	S	65	88	88.20	8	710126	#	S	46	2.73	69.40	11
658810XX	320	S	65	88	88.20	10	710127	#	S	55	68	68.15	6.50
659007XX	320	S	65	90	90.20	7	710129	#	S	57	77	77.20	8
659010XX	350	S	65	90	90.28	10	710130	#	S	64	77	77.20	8
659013XX	350	S	65	90	90.20	13	710131	#	S	40	62	62.20	9
688207XX	350	S	68	82	82.20	7	710132	400	N	33	56	56.29	13
688508XX	350	S	68	85	85.20	8	710133	#	N	42	90	90.27	9.50
689007XX	320	S	68	90	90.20	7	710135	#	S	50	70	70.20	14
689010XX	350	S	68	90	90.32	10	710139	#	N	38	58	58.27	10
689510XX	350	S	68	95	95.20	10	710142	#	S	43	70	70.16	9
708508XX	350	S	70	85	85.28	8	710143	#	S	47	84	84.28	9.50
708808XX	480	S	70	88	88.25	8	710144←	#	S	58	78	78.28	10
708812XX	320	S	70	88	88.25	12	710147	#	S	40	60	60.15	8
709007XX	320	S	70	90	90.20	7	710148	970	S	49	72.20	72.49	6
709010XX	350	S	70	90	90.32	10	710149	#	S	37	52	52.15	6
709212XX	320	S	70	92	92.20	12	710150	#	S	47	80	80.16	12.70
709510XX	350	S	70	95	95.28	10	710151	470	S	34	65	65.10	12
709513XX	350	S	70	95	95.28	13	710152	#	S	36	64	64.16	11
710051	860	S	35	48	48.13	13	710154	320	S	19	38	38.23	7
710056←	470	V	91	111	111.28	10	710156	320	S	18	32	32.23	7
710057	480	S	36	65	65.20	8	710157→	320	S	27	43	43.23	7
710060←	320	H	95	118	118.29	10	710159	#	S	43	58.47	58.62	7.50
710064	#	S	52	68	68.15	7.50	710161	2810	S	46	68.50	68.63	7.50
710069	#	S	56	72	72.16	10.90	710162	480	V	32	50	50.14	8
710070	470	S	33	44	44.15	8	710164	480	V	32	50	50.14	8
710072	#	S	57	79	79.25	13.70	710167	#	S	48	64	64.20	10
710073	#	S	54	75.50	75.78	18	710168	470	S	59	75	75.11	10
710074	#	S	57	79	79.25	13.70	710173	#	N	50	70	70.20	10
710078	470	V	45	62	62.15	8	710175	320	S	53	2.69	68.20	7
710092	410	S	66	85	85.17	8	710176	870	S	56	74	74.17	8.50
710093	#	S	60	75	75.16	5.80	710178	#	S	35	49	49.30	8
710094	660	S	65	82	82.17	7	710182	660	S	60	86	86.18	7
710097	#	S	42	56	56.29	7	710187→	320	N	52	70	70.28	8.50
710098	710	S	50	64.10	64.39	6.50	710188←	320	V	88	106	106.27	8.50
710107	#	S	52	78.40	78.49	9.80	710189←	470	V	89	105	105.28	10
710108	660	S	56	76	76.15	4.90	710190	480	V	52	68	68.15	8
710109↔	400	N	34	63	63.27	9	710192	320	S	50	60	60.27	6

Part Number	Style	Matl	Shaft	Bore	O.D.	Width	Part Number	Style	Matl	Shaft	Bore	O.D.	Width
710193	320	S	45	59	59.28	8	710305	320	S	49	70	70.28	11
710194	320	S	50	68	68.10	6.50	710305S	320	S	49	70	70.28	11
710199↔	#	N	35	54	54.15	9	710308→	320	S	40	52	52.27	6
710201	470	S	35	60	60.15	12	710309	#	S	38	52	52.15	6.30
710208	#	S	43	92	92.28	12.50	710310→	320	N	32	47	47.22	6
710213	2810	S	62	78	78.16	9.50	710311	250	S	40	54	54.15	6
710215	660	S	47	66	66.10	6	710312	320	S	52	68	68.20	13
710217	#	S	35	54	54.15	8	710313→	320	S	48	70	70.28	12
710218	#	V	35	56	56.29	10	710314←	400	N	35	56	56.29	8
710220→	320	N	41	62	62.23	9	710315→	400	S	35	56	56.29	8
710226	320	S	50	2.57	67.00	5.50	710316→	320	S	25	40	40.23	8
710228	400	S	37	62	62.23	10	710317←	320	S	32	48	48.24	10
710230	#	S	58	76	76.23	7.80	710320	480	S	48	62	62.10	9
710232	320	V	86	104	104.37	11	710322	340	S	48	62	62.28	6
710234←	320	N	68	84	84.28	8.50	710323	490	S	51	63	63.17	6
710235←	320	V	86	103	103.28	10	710324←	320	S	35	50	50.24	11
710236→	320	N	33	49	49.23	8	710325→	320	S	28	40	40.23	8
710237←	320	V	90	104	104.27	11	710326	660	S	40	64	64.16	12
710238→	320	S	46	70	70.10	8	710327→	320	S	32	48	48.24	7
710239	400	N	54	69	69.23	7.50	710328	350	S	33	50	50.24	7
710240	#	S	75	83	87.00	4	710329←	320	H	35	50	50.29	8
710242→	320	N	52	72	72.29	8	710331←	320	V	35	54	54.20	8
710245→	#	N	42	76	76.15	12	710332←	320	N	31	46	46.23	8
710246	#	N	42	90	90.27	11.90	710334←	320	N	68	86	86.28	8
710248→	660	N	45	78	78.16	11	710335	320	S	35	65	65.28	12
710249	970	S	20	26	26.24	4	710336←	400	N	35	68	68.20	9
710251	470	N	17	34	34.14	7.90	710337	340	S	47	72.20	72.49	6
710252	320	S	36	44	44.22	5	710338	660	S	39	52	52.15	6.30
710253	#	S	52	62	62.28	5.50	710339	250	S	70	112	112.17	14
710254	340	S	23	31.80	32.03	5.50	710341←	320	S	36	50	50.29	8
710255	#	S	48	70	70.20	9	710342→	320	S	20	47	47.22	8.50
710258←	320	V	115	135	135.36	10	710343	330	S	36	46	46.15	9
710259↔	320	V	37	56	56.29	9	710344	320	S	17	30	30.23	7
710260←	320	S	45	61	61.29	8	710345	320	S	45	68	68.20	12
710264→	320	Y	43	55	55.27	6	710346	490	S	15	20	20.10	5
710266	#	S	93	154	154.20	8	710347←	320	S	28	38	38.23	10
710271←	320	S	58	74	74.27	10	710348	320	S	13	22	22.20	6
710273	350	S	19	35	35.23	10	710351←	320	H	100	135	135.36	10
710276	400	N	60	103	103.18	12	710352	470	V	95	113	113.10	10
710282	320	S	32	42	42.20	8	710353→	660	S	37	58	58.10	10
710284	#	N	40	73	73.10	12.50	710354→	320	N	50	65	65.28	8
710286	320	N	42	67	67.20	10	710355→	320	N	37	50.50	50.70	6
710288←	320	S	93	114	114.30	13	710356→	470	S	48	60	60.15	9
710289→	320	S	45	67	67.16	8	710357	470	S	50	67	67.20	9
710291←	400	N	41	63	63.20	9	710359	#	S	30	45	45.20	8
710292	#	S	52	68	68.15	6.50	710360	350	S	35	72	72.29	10
710297	340	S	18	23	23.24	4	710362	490	S	17	25	25.15	5
710298→	400	N	42	63	63.27	9	710364↔	#	N	45	98	98.17	10.50
710299	660	N	17.50	27.50	27.74	7	710366←	320	H	106	126	126.37	12
710300	#	S	40	55.50	55.65	9	710367→	400	S	65	88	88.20	12

Part Number	Style	Matl	Shaft	Bore	O.D.	Width	Part Number	Style	Matl	Shaft	Bore	O.D.	Width
710368	470	S	138	152	152.20	12	717004	480	S	120	140	140.21	12
710369	470	S	145	164	264.10	14	717005←	320	S	95	110	110.29	11
710370	320	S	32	43	43.23	7	729010XX	350	S	72	90	90.20	10
710371	250	S	101	114	114.10	10	729510XX	350	S	72	95	95.28	10
710372	#	S	115	156	156.10	15.50	759008XX	320	S	75	90	90.20	8
710373	470	S	65	85	85.17	10	759010XX	320	S	75	90	90.25	10
710374	#	S	49	100	100.20	8	759510XX	350	S	75	95	95.28	10
710375	#	S	76	102	102.20	9.50	10X012010XX	350	S	100	120	120.30	10
710379	470	S	60	72	72.16	7.50	10X012012XX	350	S	100	120	120.28	12
710380	470	S	130	150	150.22	10	10X012512XX	350	S	100	125	125.28	12
710381	#	S	124	170	-	14.50	10X013012XX	350	S	100	130	130.28	12
710382	#	S	56	66	66.20	17	10X213013XX	350	S	102	130	130.28	13
710383	470	S	35	44	44.15	7	10X512513XX	320	S	105	125	125.28	13
710384	250	S	75	100	100.18	13	10X513012XX	350	S	105	130	130.28	12
710390→	320	N	60	82	82.20	12	10X514012XX	350	S	105	140	140.28	12
710396↔	400	S	35	56	56.20	9	11X013012XX	350	S	110	130	130.28	12
710398	#	S	50	72	72.20	10	11X013513XX	320	S	110	135	135.30	13
710400	470	S	58	75	75.16	9	11X014012XX	320	S	110	140	140.28	12
710403	#	S	42	62	62.10	12	11X014013XX	450	S	110	140	140.23	13
710406	470	S	140	170	170.21	14	11X014513XX	350	S	110	145	145.30	13
710407	330	S	51	62	62.13	7	11X015015XX	350	S	110	150	150.28	15
710408	320	N	42	62	62.28	7	11X2140013XX	350	S	112	140	140.32	13
710410	470	S	100	114	114.20	12	11X414013XX	350	S	114	140	140.28	13
710412	320	S	18	34	34.24	7	11X514012XX	350	S	115	140	140.28	12
710415→	320	S	32	50	50.24	8	11X514513XX	350	S	115	145	145.30	13
710416	350	S	34	48	48.24	7.50	11X514514XX	320	S	115	145	145.20	14
710418	320	N	34	53	53.29	8	11X515012XX	350	S	115	150	150.28	12
710420→	320	S	50	68	68.28	9	12X014013XX	350	S	120	140	140.28	13
710422	350	S	34	62	62.28	10	12X014512XX	350	S	120	145	145.28	12
710424	350	S	35	60	60.27	8	12X015012XX	350	S	120	150	150.28	12
710440	470	S	68	90	90.17	12	12X016012XX	350	S	120	160	160.28	12
710442→	480	N	42	59	59.16	7.70	12X25045XX	320	S	12	25	25.20	4.50
710444←	320	S	40	54	54.28	6	12X515012XX	320	S	125	150	150.28	12
710445	350	S	19	35	35.23	8	12X515512XX	320	S	125	155	155.20	12
710446→	350	S	68	88	88.29	8	12X516012XX	350	S	125	160	160.28	12
712001→	320	N	30	46	46.23	8	12X517015XX	320	S	125	170	170.20	15
712005→	320	H	65	84	84.28	9	12X815015XX	350	S	128	150	150.28	15
712006←	320	H	60	82	82.27	12	13X015010XX	470	S	130	150	150.10	10
712007	480	V	25	35	35.25	7	13X016012XX	350	S	130	160	160.28	12
712008←	320	H	28	42	42.24	8	13X016015XX	320	S	130	160	160.20	15
712010→	320	H	48	70	70.28	9	13X017012XX	350	S	130	170	170.30	12
712011	320	S	40	75	75.20	12	13X017015XX	350	S	130	170	170.28	15
712020←	320	N	40	75	75.29	12	13X516013XX	350	S	135	160	160.38	13
712551	320	S	40	56	56.29	8	13X517012XX	350	S	135	170	170.38	12
713655	320	N	35	52	52.35	8	13X815212XX	470	S	138	152	152.10	12
713771→	350	V	35	50	50.34	8	14X016012XX	320	S	140	160	160.20	12
714436	320	S	35	48	48.24	8	14X016013XX	350	S	140	160	160.27	13
714619	350	S	30	48	48.24	8	14X017012XX	320	S	140	170	170.30	12
716102←	320	H	85	105	105.28	10	14X017015XX	350	S	140	170	170.43	15
716445	350	V	75	95	95.28	10	14X018012XX	350	S	140	180	180.30	12

Part Number	Style	Matl	Shaft	Bore	O.D.	Width	Part Number	Style	Matl	Shaft	Bore	O.D.	Width
14X018018XX	320	S	140	180	180.38	18	75X10010XX	320	S	75	100	100.20	10
14X416012XX	350	S	144	160	160.25	12	75X10012XX	320	S	75	100	100.27	12
14X516414XX	470	S	145	164	164.10	14	75X10513XX	320	S	75	105	105.27	13
14X517012XX	350	S	145	170	170.45	12	75X11012XX	320	S	75	110	110.20	12
14X517515XX	350	S	145	175	175.38	15	75X11512XX	350	S	75	115	115.30	12
14X518012XX	350	S	145	180	180.28	12	75X12010XX	320	S	75	120	120.20	10
14X518510XX	350	S	145	180	180.28	12	78X10010XX	350	S	78	100	100.27	10
14X817015XX	350	S	148	170	170.28	15	78X10510XX	320	S	78	105	105.20	10
14X817015XX	350	S	148	170	170.28	15	78X11510XX	320	S	78	115	115.20	10
15X018012XX	350	S	150	180	180.35	12	80X10010XX	350	S	80	100	100.20	10
15X018015XX	350	S	150	180	180.35	15	80X10510XX	320	S	80	105	105.20	10
15X518015XX	320	S	155	180	180.23	15	80X10513XX	480	S	80	105	105.27	13
16X018510XX	350	S	160	185	185.35	10	80X11010XX	320	S	80	110	110.28	10
16X019015XX	350	S	160	190	190.35	15	80X11012XX	350	S	80	110	110.28	12
16X020012XX	320	S	160	200	200.20	12	80X12010XX	320	S	80	120	120.20	10
16X020015XX	320	S	160	200	200.20	15	80X12013XX	320	S	80	120	120.28	13
17X020015XX	350	S	170	200	200.35	15	82X10513XX	250	S	82	105	105.25	13
17X021015XX	320	S	170	210	210.20	15	85X10510XX	320	S	85	105	105.28	10
17X520015XX	320	S	175	200	200.35	15	85X10513XX	320	S	85	105	105.28	13
18X021015XX	350	S	180	210	210.35	15	85X11010XX	350	S	85	110	110.20	10
18X512013XX	350	S	185	210	210.35	13	85X11012XX	350	S	85	110	110.28	12
19X022016XX	350	S	190	220	220.35	16	85X11513XX	350	S	85	115	115.00	13
19X023016XX	320	S	190	230	230.20	16	85X12012XX	320	S	85	120	120.28	12
20X023015XX	450	S	200	230	230.35	15	85X12512XX	320	S	85	125	125.20	12
21X024015XX	350	S	210	240	240.35	15	85X13013XX	480	S	85	130	130.15	12.70
21X025015XX	320	S	210	250	250.20	15	88X11012XX	350	S	88	110	110.28	12
22X025015XX	350	S	220	250	250.35	15	90X11012XX	350	S	90	110	110.20	12
23X026015XX	350	S	230	260	260.35	15	90X11512XX	320	S	90	115	115.20	12
24X027015XX	350	S	240	270	270.35	15	90X12012XX	320	S	90	120	120.28	12
24X028016XX	320	S	240	280	280.20	16	90X12507XX	320	S	90	125	125.70	7
28X032020XX	320	S	280	320	320.45	20	90X12513XX	320	S	90	125	125.30	13
30X034020XX	320	S	300	340	340.45	20	90X14514XX	320	S	90	145	145.20	14
38X52085XX	320	S	38	52	52.25	8.50	92X12013XX	350	S	92	120	120.24	13
55X10013X	450	S	55	100	100.30	12.70	95X11010XX	320	S	95	110	110.20	10
55X1007X	320	S	55	75	75.20	7	95X11512XX	350	S	95	115	115.28	12
56X72115XX	350	S	56	72	72.40	11.50	95X12012XX	350	S	95	120	120.28	12
60X10010XX↔	320	N	60	100	100.20	10	95X12512XX	350	S	95	125	125.28	12
60X11008XX	320	S	60	110	110.20	8	95X13012XX	350	S	95	130	130.28	12
62X10007XX	320	S	62	100	100.30	7	98X12013XX	350	S	98	120	120.20	13
65X10007XX	320	S	65	100	100.30	7							
65X10010XX	350	S	65	100	100.28	10							
68X10010XX	350	S	68	100	100.20	10							
68X10013XX	350	S	68	100	100.28	13							
70X10010XX	320	S	70	100	100.20	10							
70X10013XX	350	S	70	100	100.28	13							
70X10507XX	320	S	70	105	105.30	7							
70X10513XX	350	S	70	105	105.20	13							
70X11010XX	350	S	70	110	110.20	10							
72X10010XX	350	S	72	100	100.20	10							
72X10012XX↔	320	S	72	100	100.31	12							

METRIC - PART

Part Number	Width	I.D.	O.D.	Part Number	Width	I.D.	O.D.
001R	1/32	0.031	1/32	0.031	3/32	0.094	
002R	3/64	0.047	3/64	0.047	9/64	0.141	
003R	1/16	0.063	1/16	0.063	3/16	0.188	
004R	1/16	0.063	5/64	0.078	13/16	0.813	
005R	1/16	0.063	3/32	0.094	7/32	0.219	
006R	1/16	0.063	1/8	0.125	1/4	0.250	
007R	1/16	0.063	5/32	0.156	9/32	0.281	
008R	1/16	0.063	3/16	0.188	5/16	0.313	
009R	1/16	0.063	7/32	0.219	11/32	0.344	
010R	1/16	0.063	1/4	0.250	3/8	0.375	
011R	1/16	0.063	5/16	0.313	7/16	0.438	
012R	1/16	0.063	3/8	0.375	1/2	0.500	
013R	1/16	0.063	7/16	0.438	9/16	0.563	
014R	1/16	0.063	1/2	0.500	5/8	0.625	
015R	1/16	0.063	9/16	0.563	11/16	0.688	
016R	1/16	0.063	5/8	0.625	3/4	0.750	
017R	1/16	0.063	11/16	0.688	13/16	0.813	
018R	1/16	0.063	3/4	0.750	7/8	0.875	
019R	1/16	0.063	13/16	0.813	15/16	0.938	
020R	1/16	0.063	7/8	0.875	1	1.000	
021R	1/16	0.063	15/16	0.938	1-1/16	1.063	
022R	1/16	0.063	1	1.000	1-1/8	1.125	
023R	1/16	0.063	1-1/16	1.063	1-3/16	1.188	
024R	1/16	0.063	1-1/8	1.125	1-1/4	1.250	
025R	1/16	0.063	1-3/16	1.188	1-5/16	1.313	
026R	1/16	0.063	1-1/4	1.250	1-3/8	1.375	
027R	1/16	0.063	1-5/16	1.313	1-7/16	1.438	
028R	1/16	0.063	1-3/8	1.375	1-1/2	1.500	
029R	1/16	0.063	1-1/2	1.500	1-5/8	1.625	
030R	1/16	0.063	1-5/8	1.625	1-3/4	1.750	
031R	1/16	0.063	1-3/4	1.750	1-7/8	1.875	
032R	1/16	0.063	1-7/8	1.875	2	2.000	
033R	1/16	0.063	2	2.000	2-1/8	2.125	
034R	1/16	0.063	2-1/8	2.125	2-1/4	2.250	
035R	1/16	0.063	2-1/4	2.250	2-3/8	2.375	
036R	1/16	0.063	2-3/8	2.375	2-1/2	2.500	
037R	1/16	0.063	2-1/2	2.500	2-5/8	2.625	
038R	1/16	0.063	2-5/8	2.625	2-3/4	2.750	
039R	1/16	0.063	2-3/4	2.750	2-7/8	2.875	
040R	1/16	0.063	2-7/8	2.875	3	3.000	
041R	1/16	0.063	3	3.000	3-1/8	3.125	
042R	1/16	0.063	3-1/4	3.250	3-3/8	3.375	
043R	1/16	0.063	3-1/2	3.500	3-5/8	3.625	
044R	1/16	0.063	3-3/4	3.750	3-7/8	3.875	
045R	1/16	0.063	4	4.000	4-1/8	4.125	
110R	3/32	0.094	3/8	0.375	9/16	0.563	
111R	3/32	0.094	7/16	0.438	5/8	0.625	
112R	3/32	0.094	1/2	0.500	11/16	0.688	
113R	3/32	0.094	9/16	0.563	3/4	0.750	
114R	3/32	0.094	5/8	0.625	13/16	0.813	
115R	3/32	0.094	11/16	0.688	7/8	0.875	
116R	3/32	0.094	3/4	0.750	15/16	0.938	
117R	3/32	0.094	13/16	0.813	1	1.000	
118R	3/32	0.094	7/8	0.875	1-1/16	1.063	
119R	3/32	0.094	15/16	0.938	1-1/8	1.125	
120R	3/32	0.094	1	1.000	1-3/16	1.188	
121R	3/32	0.094	1-1/16	1.063	1-1/4	1.250	
122R	3/32	0.094	1-1/8	1.125	1-5/16	1.313	
123R	3/32	0.094	1-3/16	1.188	1-3/16	1.188	
124R	3/32	0.094	1-1/4	1.250	1-7/16	1.438	
125R	3/32	0.094	1-5/16	1.313	1-1/2	1.500	
126R	3/32	0.094	1-3/8	1.375	1-9/16	1.563	
127R	3/32	0.094	1-7/16	1.438	1-5/8	1.625	
128R	3/32	0.094	1-1/2	1.500	1-11/16	1.688	
129R	3/32	0.094	1-9/16	1.563	1-3/4	1.750	
130R	3/32	0.094	1-5/8	1.625	1-13/16	1.813	
131R	3/32	0.094	1-11/16	1.688	1-7/8	1.875	
132R	3/32	0.094	1-3/4	1.750	1-15/16	1.938	
133R	3/32	0.094	1-13/16	1.813	2	2.000	
134R	3/32	0.094	1-7/8	1.875	2-1/16	2.063	
135R	3/32	0.094	1-15/16	1.938	2-1/8	2.125	
136R	3/32	0.094	2	2.000	2-3/16	2.188	
137R	3/32	0.094	2-1/16	2.063	2-1/4	2.250	
138R	3/32	0.094	2-1/8	2.125	2-5/16	2.313	
139R	3/32	0.094	2-3/16	2.188	2-3/8	2.375	
140R	3/32	0.094	2-1/4	2.250	2-7/16	2.438	
141R	3/32	0.094	2-5/16	2.313	2-1/2	2.500	
142R	3/32	0.094	2-3/8	2.375	2-9/16	2.563	
143R	3/32	0.094	2-7/16	2.438	2-5/8	2.625	
144R	3/32	0.094	2-1/2	2.500	2-11/16	2.688	
145R	3/32	0.094	2-9/16	2.563	2-3/4	2.750	
146R	3/32	0.094	2-5/8	2.625	2-13/16	2.813	
147R	3/32	0.094	2-11/16	2.688	2-7/8	2.875	
148R	3/32	0.094	2-3/4	2.750	2-5/16	2.313	
149R	3/32	0.094	2-13/16	2.813	3	3.000	
150R	3/32	0.094	2-7/8	2.875	3-1/16	3.063	
151R	3/32	0.094	3	3.000	3-3/16	3.188	
152R	3/32	0.094	3-1/4	3.250	3-7/16	3.438	
153R	3/32	0.094	3-1/2	3.500	3-11/16	3.688	
154R	3/32	0.094	3-3/4	3.750	3-15/16	3.938	
155R	3/32	0.094	4	4.000	4-3/16	4.188	
210R	1/8	0.125	3/4	0.750	1	1.000	
211R	1/8	0.125	13/16	0.813	1-1/16	1.063	
212R	1/8	0.125	7/8	0.875	1-1/8	1.125	
213R	1/8	0.125	15/16	0.938	1-3/16	1.188	
214R	1/8	0.125	1	1.000	1-1/4	1.250	
215R	1/8	0.125	1-1/16	1.063	1-5/16	1.313	
216R	1/8	0.125	1-1/8	1.125	1-3/8	1.375	
217R	1/8	0.125	1-3/16	1.188	1-7/16	1.438	
218R	1/8	0.125	1-1/4	1.250	1-1/2	1.500	

Part Number	Width	I.D.	O.D.	Part Number	Width	I.D.	O.D.
219R	1/8	0.125	1-5/16	1.313	1-9/16	1.563	
220R	1/8	0.125	1-3/8	1.375	1-5/8	1.625	
221R	1/8	0.125	1-7/16	1.438	1-11/16	1.688	
222R	1/8	0.125	1-1/2	1.500	1-3/4	1.750	
223R	1/8	0.125	1-5/8	1.625	1-7/8	1.875	
224R	1/8	0.125	1-3/4	1.750	2	2.000	
225R	1/8	0.125	7/8	0.875	2-1/8	2.125	
226R	1/8	0.125	2	2.000	2-1/4	2.250	
227R	1/8	0.125	2-1/8	2.125	2-3/8	2.375	
228R	1/8	0.125	2-1/4	2.250	2-1/2	2.500	
229R	1/8	0.125	2-3/8	2.375	2-5/8	2.625	
230R	1/8	0.125	2-1/2	2.500	2-3/4	2.750	
231R	1/8	0.125	2-5/8	2.625	2-7/8	2.875	
232R	1/8	0.125	2-3/4	2.750	3	3.000	
233R	1/8	0.125	2-7/8	2.875	3-1/8	3.125	
234R	1/8	0.125	3	3.000	3-1/4	3.250	
235R	1/8	0.125	3-1/8	3.125	3-3/8	3.375	
236R	1/8	0.125	3-1/4	3.250	3-1/2	3.500	
237R	1/8	0.125	3-3/8	3.375	3-5/8	3.625	
238R	1/8	0.125	3-1/2	3.500	3-3/4	3.750	
239R	1/8	0.125	3-5/8	3.625	3-7/8	3.875	
240R	1/8	0.125	3-3/4	3.750	4	4.000	
241R	1/8	0.125	3-7/8	3.875	4-1/8	4.125	
242R	1/8	0.125	4	4.000	4-1/4	4.250	
243R	1/8	0.125	4-1/8	4.125	4-3/8	4.375	
244R	1/8	0.125	4-1/4	4.250	4-1/2	4.500	
245R	1/8	0.125	4-3/8	4.375	4-5/8	4.625	
246R	1/8	0.125	4-1/2	4.500	4-3/4	4.750	
247R	1/8	0.125	4-5/8	4.625	4-7/8	4.875	
248R	1/8	0.125	4-3/4	4.750	5	5.000	
249R	1/8	0.125	4-7/8	4.875	5-1/8	5.125	
250R	1/8	0.125	5	5.000	5-1/4	5.250	
251R	1/8	0.125	5-1/8	5.125	5-3/8	5.375	
252R	1/8	0.125	5-1/4	5.250	5-1/2	5.500	
253R	1/8	0.125	5-3/8	5.375	5-5/8	5.625	
254R	1/8	0.125	5-1/2	5.500	5-3/4	5.750	
255R	1/8	0.125	5-5/8	5.625	5-7/8	5.875	
256R	1/8	0.125	5-3/4	5.750	6	6.000	
257R	1/8	0.125	5-7/8	5.875	6-1/8	6.125	
258R	1/8	0.125	6	6.000	6-1/4	6.250	
259R	1/8	0.125	6-1/4	6.250	6-1/2	6.500	
260R	1/8	0.125	6-1/2	6.500	6-3/4	6.750	
261R	1/8	0.125	6-3/4	6.750	7	7.000	
262R	1/8	0.125	7	7.000	7-1/4	7.250	
263R	1/8	0.125	7-1/4	7.250	7-1/2	7.500	
264R	1/8	0.125	7-1/2	7.500	7-3/4	7.750	
265R	1/8	0.125	7-3/4	7.750	8	8.000	
266R	1/8	0.125	8	8.000	8-1/4	8.250	
267R	1/8	0.125	8-1/4	8.250	8-1/2	8.500	
268R	1/8	0.125	8-1/2	8.500	8-3/4	8.750	
269R	1/8	0.125	8-3/4	8.750	9	9.000	
270R	1/8	0.125	9	9.000	9-1/4	9.250	
271R	1/8	0.125	9-1/4	9.250	9-1/2	9.500	
272R	1/8	0.125	9-1/2	9.500	9-3/4	9.750	
273R	1/8	0.125	9-3/4	9.750	10	10.000	
274R	1/8	0.125	10	10.000	10-1/4	10.250	
325R	3/16	0.188	1-1/2	1.500	1-7/8	1.875	
326R	3/16	0.188	1-5/8	1.625	2	2.000	
327R	3/16	0.188	1-3/4	1.750	2-1/8	2.125	
328R	3/16	0.188	1-7/8	1.875	2-1/4	2.250	
329R	3/16	0.188	2	2.000	2-3/8	2.375	
330R	3/16	0.188	2-1/8	2.125	2-1/2	2.500	
331R	3/16	0.188	2-1/4	2.250	2-5/8	2.625	
332R	3/16	0.188	2-3/8	2.375	2-3/4	2.750	
333R	3/16	0.188	2-1/2	2.500	2-7/8	2.875	
334R	3/16	0.188	2-5/8	2.625	3	3.000	
335R	3/16	0.188	2-3/4	2.750	3-1/8	3.125	
336R	3/16	0.188	2-7/8	2.875	3-1/4	3.250	
337R	3/16	0.188	3	3.000	3-3/8	3.375	
338R	3/16	0.188	3-1/8	3.125	3-1/2	3.500	
339R	3/16	0.188	3-1/4	3.250	3-5/8	3.625	
340R	3/16	0.188	3-3/8	3.375	3-3/4	3.750	
341R	3/16	0.188	3-1/2	3.500	3-7/8	3.875	
342R	3/16	0.188	3-5/8	3.625	4	4.000	
343R	3/16	0.188	3-3/4	3.750	4-1/8	4.125	
344R	3/16	0.188	3-7/8	3.875	4-1/4	4.250	
345R	3/16	0.188	4	4.000	4-3/8	4.375	
346R	3/16	0.188	4-1/8	4.125	4-1/2	4.500	
347R	3/16	0.188	4-1/4	4.250	4-5/8	4.625	
348R	3/16	0.188	4-3/8	4.375	4-3/4	4.750	
349R	3/16	0.188	4-1/2	4.500	4-7/8	4.875	
357R	3/16	0.188	5-1/2	5.500	5-7/8	5.875	
425R	1/4	0.250	4-1/2	4.500	5	5.000	
426R	1/4	0.250	4-5/8	4.625	5-1/8	5.125	
427R	1/4	0.250	4-3/4	4.750	5-1/4	5.250	
428R	1/4	0.250	4-7/8	4.875	5-3/8	5.375	
429R	1/4	0.250	5	5.000	5-1/2	5.500	
430R	1/4	0.250	5-1/8	5.125	5-5/8	5.625	
431R	1/4	0.250	5-1/4	5.250	5-3/4	5.750	
432R	1/4	0.250	5-3/8	5.375	5-7/8	5.875	
433R	1/4	0.250	5-1/2	5.500	6	6.000	
434R	1/4	0.250	5-5/8	5.625	6-1/8	6.125	
435R	1/4	0.250	5-3/4	5.750	6-1/4	6.250	
436R	1/4	0.250	5-7/8	5.875	6-3/8	6.375	
437R	1/4	0.250	6	6.000	6-1/2	6.500	
438R	1/4	0.250	6-1/4	6.250	6-3/4	6.750	
439R	1/4	0.250	6-1/2	6.500	7	7.000	
440R	1/4	0.250	6-3/4	6.750	7-1/4	7.250	
441R	1/4	0.250	7	7.000	7-1/2	7.500	
442R	1/4	0.250	7-1/4	7.250	7-3/4	7.750	

Part Number	Width	I.D.		O.D.		Part Number	Width	I.D.		O.D.	
443R	1/4	0.250	7-1/2	7.500	8	8.000					
444R	1/4	0.250	7-3/4	7.750	8-1/4	8.250					
445R	1/4	0.250	8	8.000	8-1/2	8.500					
446R	1/4	0.250	8-1/2	8.500	9	9.000					
447R	1/4	0.250	9	9.000	9-1/2	9.500					
448R	1/4	0.250	9-1/2	9.500	10	10.000					
449R	1/4	0.250	10	10.000	10-1/2	10.500					
450R	1/4	0.250	10-1/2	10.500	11	11.000					
451R	1/4	0.250	11	11.000	11-1/2	11.500					
452R	1/4	0.250	11-1/2	11.500	12	12.000					
453R	1/4	0.250	12	12.000	12-1/2	12.500					
454R	1/4	0.250	12-1/2	12.500	13	13.000					
455R	1/4	0.250	13	13.000	13-1/2	13.500					
456R	1/4	0.250	13-1/2	13.500	14	14.000					
457R	1/4	0.250	14	14.000	14-1/2	14.500					
458R	1/4	0.250	14-1/2	14.500	15	15.000					
459R	1/4	0.250	15	15.000	15-1/2	15.500					
460R	1/4	0.250	15-1/2	15.500	16	16.000					

SEAL TYPES



seal
specification:
001011011101100110101
001011011101100110101

x 46 -10K
x 47 -DACK3
x 48 DREQ3
x 49 -DACK1
x 50 DREQ1



NOTES



NOTES

US \$10

TIMKEN
A LEADER IN SEAL TECHNOLOGY

SEALS

- Inch/Metric
- V-Seals
- Oil Bath Seals
- KWIK-Sleeves™ - Components
- Seal Kits
- O-Rings



Timken® is the registered trademark of
The Timken Company.
www.timken.com www.timkeninfo.com

TIMKEN

© 2001 The Timken Company
Printed In the U.S.A.
60M-12-01-11 Order No. 7533

WORLDWIDE LEADER IN BEARINGS AND STEEL