



**TIMKEN**  
Where You Turn

Weatherly Index: 310/322-340  
Catalog number: 7002  
Effective date: 2009

Supersedes Heavy-Duty Wheel Bearing Applications dated 2000

## Heavy-Duty Wheel Bearing Applications

Roulements de roue pour camions-remorques

Aplicaciones de rodamientos de ruedas para servicio pesado

## HOW TO USE THIS CATALOG

Before proceeding, you will need to have the axle number or axle identification from the vehicle and axle you will be looking up:

- The vehicle option tag will most likely be found in the glove box of medium-duty vehicles.
- A tag attached to the drive and trailer axle will provide the required information on most heavy-duty trucks and trailers.
- Steering and Tag axles will most likely have the identification number cast directly into the axle itself.

With this information in hand, turn to the appropriate section of the catalog for your manufacturer.

For your convenience, we have listed the manufacturers in alphabetical order with all axle locations within this one section. You will find trailer, front axles and rear axles in the same section.

In the index under the manufacturer of the vehicle you are looking up, find the axle identification. Axle identifications are listed in alphabetical order on the left with the corresponding part location on the right.

Once the location number is identified on the right, for your axle, go to that section number. There you will find all available information with regards to the cone, cup and seals used on that axle, and any qualifiers if necessary.

*Every reasonable effort has been made to ensure the accuracy of the information contained in this writing, but no liability is accepted for errors, omissions or for any other reason.*

---

## POUR UTILISER CE CATALOGUE

Avant de poursuivre, obtenez le numéro ou l'identificateur de l'essieu correspondant au véhicule:

- Pour les camions légers, l'étiquette d'identification se retrouvera généralement dans la boîte à gants.
- Pour les camions lourds et les remorques, l'étiquette d'identification se trouvera sur l'essieu.
- Pour les essieux directeur et traîné, le numéro d'identification est typiquement gravé sur l'essieu.

Une fois muni de ces informations, consultez la section appropriée du catalogue correspondant au fabricant.

Pour faciliter votre lecture, les fabricants sont en ordre alphabétique, avec tous les essieux listés dans une même section. Les essieux de tracteur et de remorque sont ainsi rassemblés en un même endroit.

Trouvez le nom du fabricant dans l'index, puis l'identificateur de l'essieu. Les essieux sont listés en ordre alphabétique sur la gauche et l'emplacement de la pièce correspondante est sur la droite.

Une fois identifié l'emplacement de votre essieu dans le catalogue, allez à la section correspondante. Vous y trouverez toutes les informations concernant le cône, la cuvette et les joints utilisés sur cet essieu, ainsi que les particularités au besoin.

*Malgré le soin apporté à l'exactitude des informations contenues dans ce document, Timken dénie la responsabilité pour toute erreur, omission ou pour toute autre raison.*

---

## CÓMO USAR ESTE CATÁLOGO

Antes de proceder, debe tener el número del eje o la identificación del eje del vehículo y del eje que busca.

- La etiqueta de los vehículos de servicio medio se encuentra generalmente en la guantera.
- La etiqueta que se encuentra en el eje del motor y en el eje del remolque contiene la información necesaria para la mayoría de los camiones y remolques de servicio pesado.
- Es posible que los ejes de dirección y los ejes de apoyo tengan el número de identificación grabado directamente en el eje.

Con esta información, vaya a la sección correspondiente de su fabricante en este catálogo.

Para su comodidad, hemos enlistado los fabricantes en orden alfabético y las ubicaciones de sus ejes en esta misma sección. Encontrará los ejes delanteros y traseros de los remolques en la misma sección.

En el índice, en la sección del fabricante del vehículo que está buscando, encontrará la identificación del eje. Las identificaciones de los ejes aparecen en orden alfabético a la izquierda y a la derecha, se encuentra la ubicación correspondiente de la parte.

Una vez localizado el número de la ubicación de su eje, vaya a la sección indicada. Ahí encontrará toda la información disponible sobre el cono, la taza y los retenes utilizados en ese eje y cualquier clasificación si fuera necesario.

*Se realizó todo el esfuerzo posible para asegurar la precisión de la información que aparece en este catálogo, sin embargo, no nos hacemos responsables por errores, omisiones u otras razones.*

## TABLE OF CONTENTS

How To Use This Catalog	i
Pour Utiliser Ce Catalogue	i
Cómo Usar Este Catálogo	i
Applications - Tractor & Trailer Wheel Ends	1
Applications - Set-Right™ Heavy-Duty Hub Rebuild Kits	77
Applications - Kit de remontage hautes performances Timken Set-Right™	79
Aplicaciones - Kit Set-Right™ para reparación demazas de servicio pesado	81
Heavy-Duty Bearing Guide Tools	83
Interchange - Grease Seals To Oil Bath Seals	84
Heavy-Duty Wheel Seal Interchange List	85
Driveline Center Support Bearings	86
MileMate®	87
MileMate®: French Canadian	89
MileMate®: Spanish	91
Timken® 454-Series™ Wheel Bearings for Commercial Vehicles	93
Roulements de roues Timken® 454-Series™ pour véhicules commerciaux	94
Rodamientos Timken® 454-Series™ para ruedas de vehículos comerciales	95
Vehicle Identification Chart	96
Timken #1 In Comparison Test	97
Timken, le n°1 des tests comparatifs	99
Timken, N.º 1 en la prueba de comparación	101
Tapered Roller Bearing Damage Analysis	103
Timken Heavy-Duty Techtips – Free Resource	105
Timken Tech Series FREE Online Tech Training Tool	106
Notes	107

**APPLICATIONS - TRACTOR & TRAILER WHEEL ENDS**

**AMERICAN COLEMAN Axle Model Index**

Model	Line No.	Model	Line No.	Model	Line No.	Model	Line No.
SD12 .....	1	SD17 .....	1	SD9 .....	1		

Manufacturer Line Number	Inner Set	Outer Set	Inner (Cone/Cup)	Outer (Cone/Cup)	Timken	National	Stemco	SKF

**AMERICAN COLEMAN**

<b>1</b>	AXLE - FRONT DRIVE STEERING .....	-	Set401	36690	2780	-	-	-	-
		-	-	36620	36690	-	-	-	-
		-	-	594A	36620	-	-	-	-
		-	-	681A	453X	-	-	-	-
		-	-	592A	580	-	-	-	-
		-	-	672	580	-	-	-	-
		-	-	-	580	-	-	-	-
		-	-	-	572	-	-	-	-
		-	-	-	572	-	-	-	-

**ARVINMERITOR Axle Model Index**

Model	Line No.	Model	Line No.	Model	Line No.	Model	Line No.
14000 .....	53	2666 .....	2	31015 .....	47	53622H .....	119
16000 .....	1	2668 .....	2	31018 .....	47	53622N .....	119
16600 .....	1	2700 .....	5	31020 .....	47	53623 .....	119
16601 .....	1	27000 .....	44	31041 .....	47	53624 .....	119
16602 .....	1	27050 .....	44	31100 .....	47	53625 .....	119
16608 .....	2	27052 .....	44	31104 .....	47	53626 .....	119
16612 .....	2	27054 .....	44	31105 .....	47	53659N .....	119
16613 .....	2	27060 .....	44	31116 .....	47	53660H .....	119
16616 .....	2	27061 .....	44	32500 .....	48	53661 .....	119
16618 .....	2	27062 .....	44	32501 .....	48	53662 .....	119
16800 .....	3	27062A .....	44	32502 .....	48	54411H .....	63
16800W .....	4	27063 .....	45	32504 .....	48	54412 .....	63
16801 .....	3	27070 .....	45	32506 .....	48	54419 .....	63
1689 .....	2	27071 .....	45	32508 .....	48	54430TW .....	63
16900 .....	2	27072 .....	45	32509 .....	48	55411 .....	99
16901 .....	5	27450 .....	44	32514 .....	48	55417H .....	99
16901W .....	6	27451 .....	44	32518 .....	48	56334 .....	61
16902 .....	5	27452 .....	44	32519 .....	48	56400 .....	120
16902W .....	6	27454 .....	44	32520 .....	48	56401 .....	121
16903 .....	5	27460 .....	22	32521 .....	48	56410 .....	121
16903W .....	6	27460 .....	53	32550H .....	30	56411 .....	121
16905 .....	5	27461 .....	44	32550TW .....	30	56412 .....	120
16905W .....	6	27462 .....	44	32552 .....	48	56413 .....	120
16910 .....	5	27462A .....	44	32553 .....	48	56427 .....	120
1692 .....	2	27463 .....	44	32556 .....	48	56429P .....	121
16920 .....	5	27463A .....	44	40140 .....	97	56430 .....	121
16920W .....	6	27465 .....	22	53308H .....	63	56431P .....	120
1693 .....	2	27465A .....	53	53411H .....	63	56432 .....	121
16930 .....	6	27620 .....	44	53440 .....	63	56433P .....	120
16930W .....	6	2770 .....	2	53512H .....	119	56450 .....	120
16931 .....	6	2771 .....	2	53521 .....	63	56451 .....	120
16931W .....	6	2774 .....	2	53526 .....	63	56460 .....	120
2600 .....	5	2775 .....	2	53543 .....	63	56461 .....	120
26060 .....	2	2776 .....	2	53547 .....	63	56462 .....	121
26061 .....	7	2777 .....	2	53560H .....	63	56463 .....	121
26062 .....	2	30000 .....	46	53565 .....	63	56466 .....	121
26063 .....	2	30003 .....	46	53566 .....	63	56467 .....	121
2650 .....	2	30004 .....	46	53567H .....	119	56468 .....	121
2652 .....	5	30012 .....	46	53581TW .....	63	58267 .....	64
2652P .....	2	30020 .....	46	53586H .....	63	5B715M .....	127
2653 .....	2	30023 .....	46	53587 .....	63	65456P .....	64
2653P .....	2	30062 .....	46	53588TW .....	63	65457P .....	64
2660 .....	2	30063 .....	46	53589W .....	63	65743 .....	118
2661 .....	2	30064 .....	46	53591 .....	63	66714 .....	69
2662 .....	2	31007 .....	47	53595 .....	63	66714W .....	69
2663 .....	2	31008 .....	47	53599W .....	63	66715 .....	69
2664 .....	2	31009 .....	47	53620H .....	119	66743 .....	69
2665 .....	2	31013 .....	47	53622 .....	119	66766 .....	69

HEAVY-DUTY WHEEL BEARING APPLICATIONS

**ARVINMERITOR Axle Model Index (continued)**

Model	Line No.	Model	Line No.	Model	Line No.	Model	Line No.
66767	69	E102	63	FD219	16	FF921RDA	16
66782	69	E105	63	FD900	14	FF921RDH	16
66783	69	E150	63	FD900DPA	14	FF921TW	16
75350	64	E200	63	FD900DPH	14	FF930	33
75351	64	E300	63	FD900H	14	FF931	16
75356	64	E301	99	FD900N	14	FF931A	16
75357	64	E302	63	FD900P	14	FF931P	16
75743	118	E350	100	FD900TW	14	FF931TW	16
75746W	118	E370	100	FD900W	14	FF932	19
75764W	118	ELDD	87	FD901	50	FF933	19
75768W	118	ELHD	87	FD901DPH	14	FF934	33
75769W	118	EQDD	97	FD901H	14	FF941	16
75780W	118	EQHD	97	FD901P	14	FF941A	16
76410	121	ERDD	97	FD901TW	14	FF942	40
76414	69	ERLD	98	FD903	14	FF943	33
76715	69	ERLHD	98	FD921	37	FF944	32
76743	69	ERQDD	97	FD931	9	FF961	40
76744	69	ERQHD	97	FD931N	9	FF966	54
76745	69	ESH	97	FD931TW	9	FF971	20
76746	69	ESQHD	97	FD933	37	FG900	21
76779	69	ETRDD	97	FD961	33	FG900N	21
76783	69	F104	101	FDS1600	8	FG900TW	21
76784	69	F105	101	FDS1600RSA	8	FG901	22
76785	69	F106	101	FDS18000	10	FG903	22
76788	69	F140	101	FDS18000N	10	FG931	19
76789	69	F140D	101	FDS1800RSA	10	FG941	19
76790	69	F142	66	FDS1800TW	10	FG943	40
76810	69	F145	101	FDS1801RSA	10	FH	61
76811	69	F146	101	FDS1801TW	10	FH900	31
76820	69	F147	101	FDS1802RSA	10	FH901	23
79744P	86	F2090	26	FDS1805	56	FH901N	23
79746	86	F2090H	26	FDS1805RDH	56	FH901P	23
79747P	86	F2090H73	26	FDS1807	56	FH901RDA	23
79750P	86	F2090W	26	FDS1807RDH	56	FH901RDH	23
93426N	63	F2090W73	26	FDS1808	56	FH903	32
93440	63	F2094	57	FDS1808RDH	56	FHD	61
93548N	63	F233	29	FDS2100	56	FHF	61
93558N	63	F235	27	FDS2101	56	FHR	61
94427H	63	F245	101	FDS2102	56	FL900	32
94440	63	F3100CW	27	FDS75	55	FL901	24
94441H	63	F3100W	27	FDS750	13	FL901N	24
95700	99	F3200W	27	FDS750BH	13	FL901P	24
96710	121	F340	101	FDS750CH	13	FL901RDA	24
96711	121	F341	101	FDS750CN	13	FL921	32
B100	60	F345	101	FDS751CN	15	FL931	24
B1055	61	F409CW	27	FDS75N	11	FL931N	24
B140	60	F460	28	FE900	18	FL931P	24
B155	62	F462	28	FE900DPA	18	FL931RDA	24
B760	63	F464	28	FE900DPH	18	FL936	32
BH150	59	F466	28	FE900H	18	FL941	24
C100	63	F7900	52	FE900HD	18	FL942	32
D100	63	F7900N	29	FE900N	18	FL943	32
D140	63	F7901	42	FE900P	18	FL951	24
D3020	64	F7910	42	FE900TW	18	FLP01RDH	24
D3025	64	FC900	58	FE901	34	FU900	25
D436	69	FC900H	12	FE903	34	FU900P	25
D450	67	FC900N	12	FE921	33	FU910	36
D451	67	FC900TW	12	FE931	34	FU935	38
D460	67	FC901	12	FE970	17	FV SER.	124
D4600	67	FC901H	12	FE970TW	17	G161	100
D461	67	FC901N	12	FF900	33	G262	100
D462	69	FC901TW	12	FF901	51	G341	100
D4640	67	FC903	35	FF901H	16	G361	100
D472	86	FC921	35	FF901N	16	G362	100
D473	86	FC931	9	FF901P	16	H100	61
DD3025	64	FC931N	9	FF901RDA	16	H100A	61
DD4600	67	FC941	39	FF901RDH	16	H101	61
DD4640	67	FD208	14	FF901TW	16	H110	61
DH	66	FD209	14	FF903	16	H120	59
DHD	66	FD211	16	FF920	33	H130	61
E100	63	FD215	16	FF921	16	H140	102

**ARVINMERITOR Axle Model Index (continued)**

Model	Line No.	Model	Line No.	Model	Line No.	Model	Line No.
H141	102	LH	87	R3102W	118	SDF450	84
H145	59	LHD	87	R355	65	SQ100AL	76
H150	61	LHDD	87	R601	115	SQ100PAL	68
H151	59	LHF	87	RA173	71	SRDR	65
H153	59	LHR	87	RD20160	85	SSHD	76
H156	59	LT200	87	RD23160	85	STDA	82
H161	61	LT300	87	RD23164	85	SUDDB	77
H162	61	LT301	104	RD25160	85	SUDR	65
H164P	61	LT310	105	RD26160	85	SW100P	68
H170	102	LT340	105	RF16145	43	SW452	72
H172	61	PR100	108	RF21155	43	SW456A	84
H173	61	PR101	108	RF21156	43	SWD459	83
H175	61	PR102	108	RF21355	49	T11311	134
H200	61	PR103	108	RHD	16	T13	130
H240	61	PR104	108	RL SER.	124	T14	122
H250	59	PR105	103	RN SER.	126	T14000	122
H300	61	PR106	108	RP20160	85	T17	123
H300A	61	PR107	108	RP23160	85	T17000	123
H301	61	PR118ZH	109	RP23164	85	T17029	123
H302	61	PR150	109	RP25160	85	T17127	123
H302HD	61	PR151	109	RP26160	85	T17129	123
H310	61	PR152	109	RQ SER.	126	T17227	123
H320	59	PR200	110	RR20160	85	T17229	123
H340	61	PR201	110	RR23160	85	T17237	123
H341	61	PR202	109	RR23164	85	T18	123
H350	59	PR203	110	RR25160	85	T18127	123
H362	59	PR204	110	RS17141	80	T20	131
H370	59	PR205	110	RS20145	81	T2000	133
H373	61	PR206	110	RS20230	81	T25	132
H601	61	PR207	110	RS21160	85	THD SER.	122
HH	61	PR50H	111	RS21161	85	TH SER.	122
HHD	61	PR50N	111	RS23160	85	TK	91
HHR	61	PRM150P	107	RS23160A	73	TK4270	91
JD1448	2	PS150	110	RS23160C	73	TK4270	123
JD1448	41	PS151	110	RS23161	85	TK4670	91
JH	87	PS152	110	RS23180	81	TK4670	123
JHD	87	PS200	110	RS23185	81	TK6680	90
JHR	87	PS201	110	RS23186	81	TKD	91
L	87	PS202	110	RS23380	81	TKD SER.	123
L100	87	PS203	110	RS24160	85	TKLD SER.	124
L101	87	PS50H	111	RS24161	85	TKL SER.	124
L110	105	Q101	112	RS25160	85	TKL, TKLD, TLD, TL, TRD	88
L110A	105	Q111	113	RS25161	85	TKN	90
L140	87	Q201	112	RS26160	85	TKN6270	96
L143	105	Q265	97	RS26160	85	TKN6570	96
L145	87	Q301	112	RS26161	85	TKN6610	96
L148	106	QT200	97	RS26180	81	TKN6670	96
L155	104	QT201	112	RS26185	81	TKNC	90
L161	104	QT301	112	RS26380	81	TKND	91
L162	104	QT341	97	RS30180	79	TKND SER.	123
L172	106	QT342	89	RS38380	78	TKN SER.	126
L200	87	QT342A	97	RT141	112	TKP	91
L201	87	QT360	74	RT170	74	TKP SER.	123
L240	87	R110A	71	RT270	74	TK SER.	123
L245	87	R112	116	RT46160	82	TLD SER.	124
L265	104	R113	115	RT46160A	73	TL SER.	124
L300	87	R114	115	RT48180	81	TM	94
L301	104	R115	115	RT48185	81	TM20000	94
L310	105	R130	74	RT48380	81	TM20000	127
L340	87	R141	70	RT52160	82	TM22500	94
L345	87	R141P	70	RT52180	73	TM22500	127
L350	87	R143P	71	RT52380	81	TM25000	127
L351	106	R143W	71	RT58180	79	TN	90
L361	106	R153	74	RT58380	79	TN4270	96
L362	106	R160P	65	RT70380	78	TN4560	96
L365	104	R164	117	RX180	127	TN4570	96
L370	106	R200A	71	SBD1500	120	TN4610	96
L371	106	R202P	71	SBD1501	120	TN4680	96
LD	87	R241	114	SBD1502	121	TN6270	96
LDD	87	R243	114	SBD1555A	75	TN6560	96
LDF	87	R3100W	118	SD353	118	TN6570	96

**ARVINMERITOR Axle Model Index (continued)**

Model	Line No.	Model	Line No.	Model	Line No.	Model	Line No.
TN6610	96	TQ	90	TR8870	94		
TN6670	96	TQ4270	96	TR9670	94		
TN6680	96	TQ4670	96	TR9870	94		
TNC	90	TQC	96	TRD	94		
TNC SER.	126	TQD	90	TRD SER.	127		
TND	90	TQD SER.	126	TR SER.	127		
TND SER.	126	TQ SER.	126	TT	93		
TN SER.	126	TR	93	TT9670	94		
TP	92	TR	94	TT9670	127		
TP4670	92	TR4560	94	TT9870	94		
TP4680	92	TR4670	94	TT9870	127		
TP6670	92	TR767	95	TU SER.	125		
TP6680	90	TR767	129	TWVC	124		
TP8670	92	TR8670	82	U170	77		
TP SER.	126	TR8670	94	U180	79		
TP SER.	128	TR8680	82				

Manufacturer Line Number	Inner Set	Outer Set	Inner (Cone/Cup)	Outer (Cone/Cup)	Timken	National	Stemco	SKF

**ARVINMERITOR**

<b>1</b>	FRONT AXLE	-	-	623	453X	-	-	-	-
		-	-	612	-	-	-	-	-
<b>2</b>	FRONT AXLE	-	-	6379	557S	-	370066A	-	40086
		-	-	6320	552A	-	-	-	-
<b>3</b>	FRONT AXLE	-	-	6379	557S	-	370066A	-	40086
		-	-	6320	552A	-	-	-	-
<b>4</b>	FRONT AXLE	-	-	623	-	-	-	-	-
		-	-	612	-	-	-	-	-
<b>5</b>	FRONT AXLE - 2.56" Inner Cone I.D.	-	-	6379	557S	-	370066A	-	40086
		-	-	6320	552A	-	-	-	-
	FRONT AXLE - 2.62" Inner Cone I.D. & .17" Cone Front Face Radius	-	-	6386	557S	-	370066A	-	40086
		-	-	6320	552A	-	-	-	-
	FRONT AXLE - 2.62" Inner Cone I.D. & .25" Cone Front Face Radius	-	-	6389	557S	-	370066A	-	40086
		-	-	6320	552A	-	-	-	-
<b>6</b>	FRONT AXLE - 2.56" Inner Cone I.D.	-	-	6379	557S	-	370066A	-	40086
		-	-	6320	552A	-	-	-	-
	FRONT AXLE - 2.62" Inner Cone I.D. & .17" Cone Front Face Radius	-	-	6386	557S	-	370066A	-	40086
		-	-	6320	552A	-	-	-	-
<b>7</b>	FRONT AXLE	-	-	-	59175	-	-	-	-
		-	-	-	59412	-	-	-	-
<b>8</b>	FRONT AXLE	-	Set414	64450	HM218248	-	-	-	-
		-	-	64700	HM218210	-	-	-	-
<b>9</b>	FRONT AXLE	-	-	39581	3585	TKR847	370001A	308-0836	35066
		-	-	39520	3525	-	-	-	-

Manufacturer Line Number	Inner Set	Outer Set	Inner (Cone/Cup)	Outer (Cone/Cup)	Timken	National	Stemco	SKF

**ARVINMERITOR (continued)**

<b>10</b>	FRONT AXLE .....	-	-	71450	52400	-	-	-	-
		-	-	71750	52637	-	-	-	-
<b>11</b>	FRONT AXLE .....	Set408	-	39590	387AS	-	-	-	-
		-	-	39520	382A	-	-	-	-
<b>12</b>	FRONT AXLE .....	Set410	-	45284	2780	-	370010A	-	28820
		-	-	45220	2720	-	-	-	-
	FRONT AXLE - FORD .....	Set410	-	45284	25880	-	370010A	-	28820
		-	-	45220	25820	-	-	-	-
<b>13</b>	FRONT AXLE .....	-	-	47490	395A	-	-	-	-
		-	-	47420	394A	-	-	-	-
<b>14</b>	FRONT AXLE .....	-	-	39581	3585	-	370010A	-	28820
		-	-	39520	3525	-	-	-	-
<b>15</b>	FRONT AXLE .....	-	-	33287	395A	-	-	-	-
		-	-	33472	394A	-	-	-	-
<b>16</b>	FRONT AXLE .....	Set412	Set406	HM212047	3782	TKR847	370001A	308-0836	35066
		-	-	HM212011	3720	-	-	-	-
<b>17</b>	FRONT AXLE .....	-	Set412	756A	HM212047	-	370007A	-	48794
		-	-	752	HM212011	-	-	-	-
<b>18</b>	FRONT AXLE - 1st Design .....	-	Set406	557A	3782	TKR847	370001A	308-0836	35066
		-	-	553X	3720	-	-	-	-
	FRONT AXLE - 2nd Design .....	-	Set406	HM212044	3782	TKR847	370001A	308-0836	35066
		-	-	HM212011	3720	-	-	-	-
<b>19</b>	FRONT AXLE .....	Set413	Set406	HM212049	3782	TKR847	370001A	308-0836	35066
		-	-	HM212011	3720	-	-	-	-
<b>20</b>	FRONT AXLE .....	-	Set412	756A	HM212047	-	370057A	-	48796
		-	-	752	HM212011	-	-	-	-
<b>21</b>	FRONT AXLE .....	-	-	6386	537	-	370008A	-	39380
		-	-	6320	532A	-	-	-	-
<b>22</b>	FRONT AXLE .....	-	-	6389	537	-	370008A	-	39380
		-	-	6320	532A	-	-	-	-
<b>23</b>	FRONT AXLE .....	Set423	-	6461A	3979	TKR863	370048A	309-0864	43764
		-	-	6420	3920	-	-	-	-
	FRONT AXLE - FORD .....	Set423	-	6461A	555-S	TKR863	370048A	309-0864	43764
		-	-	6420	552A	-	-	-	-
<b>24</b>	FRONT AXLE .....	Set423	-	6461A	555-S	TKR863	370048A	309-0864	43764
		-	-	6420	552A	-	-	-	-

HEAVY-DUTY WHEEL BEARING APPLICATIONS

Manufacturer Line Number	Inner Set	Outer Set	Inner (Cone/Cup)	Outer (Cone/Cup)	Timken	National	Stemco	SKF

**ARVINMERITOR** (continued)

<b>25</b>								
FRONT AXLE .....	-	-	-	749	-	-	-	-
	-	-	-	742	-	-	-	-
<b>26</b>								
FRONT AXLE .....	-	-	594	498	-	-	-	-
	-	-	592A	493	-	-	-	-
<b>27</b>								
FRONT AXLE .....	-	-	71450	52400	-	-	-	-
	-	-	71750	52637	-	-	-	-
<b>28</b>								
FRONT AXLE .....	-	-	3578	2689	-	-	-	-
	-	-	3525	2631	-	-	-	-
<b>29</b>								
FRONT AXLE .....	-	-	64450	52400	-	-	-	-
	-	-	64700	52637	-	-	-	-
<b>30</b>								
FRONT AXLE .....	-	-	3778	2790	-	-	-	-
	-	-	3720	2720	-	-	-	-
<b>31</b>								
FRONT AXLE .....	Set423	-	6461A	555-S	TKR863	370048A	309-0864	43764
	-	-	6420	552A	-	-	-	-
<b>32</b>								
FRONT AXLE .....	Set423	-	6461A	555-S	TKR863	370048A	309-0864	43764
	-	-	6420	552A	-	-	-	-
<b>33</b>								
FRONT AXLE .....	Set412	Set406	HM212047	3782	TKR847	370001A	308-0836	35066
	-	-	HM212011	3720	-	-	-	-
<b>34</b>								
FRONT AXLE .....	-	Set406	557A	3782	TKR847	370001A	308-0836	35066
	-	-	553X	3720	-	-	-	-
<b>35</b>								
FRONT AXLE .....	Set410	-	45284	2780	-	370010A <sup>12</sup>	-	28820
	-	-	45220	2720	-	370054A <sup>13</sup>	-	28832
<b>36</b>								
FRONT AXLE .....	-	-	-	749	-	-	-	-
	-	-	-	742	-	-	-	-
<b>37</b>								
FRONT AXLE .....	-	-	39581	3585	TKR847	370001A	308-0836	35066
	-	-	39520	3525	-	-	-	-
<b>38</b>								
FRONT AXLE .....	-	-	-	555-S	-	-	-	-
	-	-	-	552A	-	-	-	-
<b>39</b>								
FRONT AXLE .....	-	-	JM207049A	25877	-	370150A	308-0866	28758
	-	-	JM207010	25820	-	-	-	-
<b>40</b>								
FRONT AXLE .....	Set413	Set406	HM212049	3782	TKR847	370001A	308-0836	35066
	-	-	HM212011	3720	-	-	-	-

<sup>12</sup> Through 9/72 <sup>13</sup> From 10/72

Manufacturer Line Number	Inner Set	Outer Set	Inner (Cone/Cup)	Outer (Cone/Cup)	Timken	National	Stemco	SKF

**ARVINMERITOR (continued)**

<b>41</b>								
FRONT AXLE .....	-	-	6379	557S	-	370066A	-	40086
	-	-	6320	552A	-	-	-	-
<b>42</b>								
FRONT AXLE .....	-	-	64450	-	-	-	-	-
	-	-	64700	-	-	-	-	-
<b>43</b>								
FRONT AXLE .....	-	-	JHM720249	52375	-	-	-	-
	-	-	JHM720210	52637	-	-	-	-
<b>44</b>								
FRONT AXLE - 3.875" Shaft .....	-	-	6386	537	-	370165A	-	38747
	-	-	6320	532A	-	-	-	-
FRONT AXLE - 4.0" Shaft .....	-	-	6389	557S	-	370066A	-	40086
	-	-	6320	552A	-	-	-	-
<b>45</b>								
FRONT AXLE .....	-	-	6379	557S	-	370066A	-	40086
	-	-	6320	552A	-	-	-	-
<b>46</b>								
FRONT AXLE .....	-	-	3382	1779	-	-	-	-
	-	-	3320	1729X	-	-	-	-
<b>47</b>								
FRONT AXLE .....	-	-	3578	2689	-	-	-	-
	-	-	3525	2631	-	-	-	-
<b>48</b>								
FRONT AXLE - 1.313" Outer Cone I.D. ....	-	-	3778	2790	-	-	-	-
	-	-	3720	2720	-	-	-	-
FRONT AXLE - 1.375" Outer Cone I.D. ....	-	-	3778	25877	-	-	-	-
	-	-	3720	25820	-	-	-	-
<b>49</b>								
FRONT AXLE .....	-	-	JHM720249	52375	-	-	-	-
	-	-	JHM720210	52637	-	-	-	-
<b>50</b>								
FRONT AXLE .....	-	-	39581	3585	TKR847	370001A	308-0836	35066
	-	-	39520	3525	-	-	-	-
<b>51</b>								
FRONT AXLE .....	Set412	Set406	HM212047	3782	TKR847	370001A	308-0836	35066
	-	-	HM212011	3720	-	-	-	-
<b>52</b>								
FRONT AXLE .....	-	-	64450	-	-	-	-	-
	-	-	64700	-	-	-	-	-
<b>53</b>								
FRONT AXLE - 5.375" Seal Bore .....	-	-	6386	537	-	370165A	-	38747
	-	-	6320	532A	-	-	-	-
FRONT AXLE - 5.625" Bore Seal .....	-	-	6389	557S	-	370066A	-	40086
	-	-	6320	552A	-	-	-	-
<b>54</b>								
FRONT AXLE .....	Set413	Set406	HM212049	3782	TKR847	370001A	308-0836	35066
	-	-	HM212011	3720	-	-	-	-
<b>55</b>								
FRONT AXLE .....	-	-	JM207049A	25877	-	370150A	308-0866	28758
	-	-	JM207010	25820	-	-	-	-

HEAVY-DUTY WHEEL BEARING APPLICATIONS

Manufacturer Line Number	Inner Set	Outer Set	Inner (Cone/Cup)	Outer (Cone/Cup)	Timken	National	Stemco	SKF

**ARVINMERITOR** (continued)

<b>56</b>	FRONT AXLE .....	-	-	JHM720210	52375	-	-	-	-
		-	-	JHM720210	52637	-	-	-	-
<b>57</b>	FRONT AXLE .....	-	-	594	498	-	-	-	-
		-	-	592A	493	-	-	-	-
<b>58</b>	FRONT AXLE .....	Set410	-	45284	-	-	-	-	-
		-	-	45220	-	-	-	-	-
<b>59</b>	REAR AXLE - 3.94" Shaft .....	-	Set408	495AX	39590	-	370008A	-	39380
		-	-	493	39520	-	-	-	-
	REAR AXLE - 3.87" Shaft .....	-	Set408	495AX	39590	TKR848	370024A	309-0915	38750
		-	-	493	39520	-	-	-	-
	REAR AXLE - 4.27" Shaft .....	-	-	495AX	3984	-	370030A	309-0961	42800
		-	-	493	3920	-	-	-	-
<b>60</b>	REAR AXLE .....	-	-	387AS	368A	-	-	-	-
		-	-	382A	362A	-	-	-	-
<b>61</b>	REAR AXLE - 3.94" Shaft .....	-	-	495AX	3984	-	370008A	-	39380
		-	-	493	3920	-	-	-	-
	REAR AXLE - DODGE 3.87" Shaft .....	-	Set408	42688	39590	-	370033A	-	38709
		-	-	42620	39520	-	-	-	-
	REAR AXLE - FORD, Navistar 3.87" Shaft .....	Set411	Set408	47686	39590	TKR849	370023A	309-0912	38780
		-	-	47620	39520	-	-	-	-
	REAR AXLE - FORD, GM 3.94" Shaft .....	-	Set408	495AX	39590	-	370009A	309-0957	37425
		-	-	493	39520	-	-	-	39420
<b>62</b>	REAR AXLE .....	Set402	-	582	462	-	370046A	-	31307
		-	-	572	453X	-	-	-	-
<b>63</b>	REAR AXLE .....	-	-	3984	462	-	370046A	-	31307
		-	-	3920	453X	-	-	-	-
<b>64</b>	REAR AXLE .....	-	-	575	575	TKR850	370036A	307-0713	40136
		-	-	572	572	-	-	-	-
	REAR AXLE - 4.27" Shaft .....	Set402	-	582	42687	TKR850	370036A	307-0713	40136
		-	-	572	42620	-	-	-	-
<b>65</b>	REAR AXLE - 4.27" Shaft .....	-	Set401	598A	580	-	370030A	309-0961	42800
		-	-	592-A	572	-	-	-	-
	REAR AXLE - 4.77" Shaft .....	Set404	Set401	598A	580	TKR861	370003A	309-0973	47697
		-	-	592A	572	-	-	-	-
	REAR AXLE - 4.82" Shaft .....	Set404	Set401	598A	580	-	-	-	-
		-	-	592A	572	-	-	-	-
	REAR AXLE - 4.88" Shaft .....	Set404	Set401	598A	580	-	370004A	-	48884
		-	-	592A	572	-	-	-	-
<b>66</b>	REAR AXLE .....	-	-	33281	3982	-	370047A	309-0935	34384
		-	-	33462	3920	-	-	-	34387
<b>67</b>	REAR AXLE .....	-	-	760	749	-	370004A	-	48884
		-	-	572	742	-	-	-	-

Manufacturer Line Number	Inner Set	Outer Set	Inner (Cone/Cup)	Outer (Cone/Cup)	Timken	National	Stemco	SKF

**ARVINMERITOR (continued)**

REAR AXLE - 3.94" Shaft .....	-	-	495AX	749	-	370008A	-	39380
	-	-	493	742	-	-	-	-
REAR AXLE - 4.77" Shaft .....	-	Set401	681A	580	-	370006A	309-0970	47699
	-	-	672	572	-	-	-	-
<b>68</b>								
REAR AXLE .....	-	Set401	681A	580	-	370006A	309-0970	47699
	-	-	672	572	-	-	-	-
<b>69</b>								
REAR AXLE .....	-	-	759	749	-	-	-	-
	-	-	752	742	-	-	-	-
<b>70</b>								
REAR AXLE .....	-	Set401	594	580	TKR858	370021A	309-0964	45160
	-	-	592-A	572	-	-	-	-
<b>71</b>								
REAR AXLE .....	-	Set401	681A	580	-	370006A	309-0970	47699
	-	-	672	572	-	-	-	-
<b>72</b>								
REAR AXLE .....	-	-	759	749	-	370004A	-	48884
	-	-	752	742	-	-	-	-
<b>73</b>								
REAR AXLE .....	Set403	Set401	594A	580	TKR861	370003A	309-0973	47697
	-	-	592A	572	-	-	-	-
<b>74</b>								
REAR AXLE .....	Set404	Set401	598A	580	TKR861	370003A	309-0973	47697
	-	-	592A	572	-	-	-	-
<b>75</b>								
REAR AXLE .....	Set402	-	582	42687	-	370030A	309-0961	42800
	-	-	572	42620	-	-	-	-
<b>76</b>								
REAR AXLE .....	-	-	681A	575	-	370006A	309-0970	47699
	-	-	672	572	-	-	-	-
<b>77</b>								
REAR AXLE .....	-	-	782	749	-	370120A	-	55177
	-	-	772	742	-	-	-	-
<b>78</b>								
REAR AXLE .....	-	-	782	6580	-	-	-	-
	-	-	772	6535	-	-	-	-
<b>79</b>								
REAR AXLE .....	-	-	782	749	-	370120A	-	55177
	-	-	772	742	-	-	-	-
<b>80</b>								
REAR AXLE .....	Set411	Set408	47686	39590	TKR849	370023A	309-0912	38780
	-	-	47620	39520	-	-	-	-
<b>81</b>								
REAR AXLE .....	Set404	Set401	598A	580	TKR861	370003A	309-0973	47697
	-	-	592A	572	-	-	-	-
<b>82</b>								
REAR AXLE .....	Set403	Set401	594A	580	TKR861	370003A	309-0973	47697
	-	-	592A	572	-	-	-	-

HEAVY-DUTY WHEEL BEARING APPLICATIONS

Manufacturer Line Number	Inner Set	Outer Set	Inner (Cone/Cup)	Outer (Cone/Cup)	Timken	National	Stemco	SKF

**ARVINMERITOR** (continued)

<b>83</b>								
REAR AXLE .....	-	-	760	749	-	370004A	-	48884
	-	-	752	742	-	-	-	-
<b>84</b>								
REAR AXLE .....	-	-	-	749	-	370004A	-	48884
	-	-	-	742	-	-	-	-
<b>85</b>								
REAR AXLE - 4.77" Shaft .....	Set403	Set401	594A	580	TKR861	370003A	309-0973	47697
	-	-	592A	572	-	-	-	-
<b>86</b>								
REAR AXLE .....	-	-	-	780	-	-	-	-
	-	-	-	772	-	-	-	-
<b>87</b>								
REAR AXLE .....	Set402	-	582	42687	-	370030A <sup>14</sup>	309-0961	42800
	-	-	572	42620	-	-	-	-
REAR AXLE - Inner Seal Width .500" .....	Set411	Set408	47686	39590	TKR849	370023A	309-0912	38780
	-	-	47620	39520	-	-	-	-
<b>88</b>								
TRAILER AXLE - w/o Budd Whls. and Gunite 81012 Anti-Skid Control. ....	-	-	-	-	-	-	-	-
	-	Set413	665A	HM212049	TKR853	370037A	307-0744	43752
	-	-	653	HM212011	-	-	-	-
TRAILER AXLE - Budd Whls. ....	Set405	Set413	663	HM212049	-	-	-	-
	-	-	653	HM212011	-	-	-	-
TRAILER AXLE - w/Gunite 81012 Anti-Skid Control. ....	-	-	-	-	-	-	-	-
	-	Set413	665A	HM212049	TKR856	370022A	309-0903	45099
	-	-	653	HM212011	-	-	-	-
<b>89</b>								
REAR AXLE - STANDARD AXLE .....	Set404	Set401	598A	580	TKR861	370003A	309-0973	47697
	-	-	592A	572	-	-	-	-
REAR AXLE - BROCKWAY .....	-	Set401	681A	580	-	370006A	309-0970	47699
	-	-	672	572	-	-	-	-
<b>90</b>								
TRAILER AXLE .....	Set414	Set413	HM218248	HM212049	TKR859	370025A	307-0743	46305
	-	-	HM218210	HM212011	-	-	-	-
<b>91</b>								
TRAILER AXLE - .14" Cone FF Radius .....	Set405	Set413	663	HM212049	TKR850	370036A	307-0713	40136
	-	-	653	HM212011	-	-	-	-
TRAILER AXLE - .27" Cone FF Radius .....	-	Set413	663A	HM212049	TKR850	370036A	307-0713	40136
	-	-	653	HM212011	-	-	-	-
<b>92</b>								
TRAILER AXLE .....	Set415	Set415	HM518445	HM518445	TKR851	370065A	307-0723	42623
	-	-	HM518410	HM518410	-	-	-	-
<b>93</b>								
TRAILER AXLE - w/o Budd and Motor Wheel Whls. Exc. TR4670 Axle .....	-	-	-	-	-	-	-	-
	Set403	-	594A	-	-	-	-	-
	-	-	592A	-	-	-	-	-
<b>94</b>								
TRAILER AXLE .....	Set403	Set401	594A	580	TKR861	370003A	309-0973	47697
	-	-	592A	572	-	-	-	-
<b>95</b>								
TRAILER AXLE .....	Set403	-	594A	HM516449	TKR861	370003A	309-0973	47697
	-	-	592A	HM516410	-	-	-	-

<sup>14</sup> Standard Axle, White & Dodge Ser. To 1491999

Manufacturer Line Number	Inner Set	Outer Set	Inner (Cone/Cup)	Outer (Cone/Cup)	Timken	National	Stemco	SKF

**ARVINMERITOR (continued)**

<b>96</b>	TRAILER AXLE .....	Set414	Set413	HM218248 HM218210	HM212049 HM212011	TKR859 -	370025A -	307-0743 -	46305 -
<b>97</b>	REAR AXLE - STANDARD AXLE .....	Set404	Set401	598A 592A	580 572	TKR861 -	370003A -	309-0973 -	47697 -
	REAR AXLE - BROCKWAY .....	-	Set401	681A 672	580 572	- -	370006A -	309-0970 -	47699 -
<b>98</b>	REAR AXLE - EXCEPT FRONT UNIT .....	Set402	-	582 572	42687 42620	- -	370030A -	309-0961 -	42800 -
	REAR AXLE - FRONT UNIT .....	Set404	Set401	598A 592A	580 572	TKR861 -	370003A -	309-0973 -	47697 -
<b>99</b>	REAR AXLE - STANDARD AXLE - GMC 4.33" Outer Cup O.D. ....	- -	- -	- 33281 33462	- 3982 3920	- - -	- 370047A -	- 309-0935 -	- 34384 34387
<b>100</b>	REAR AXLE .....	-	-	B12235YK	KA11950Z	-	-	-	-
<b>101</b>	REAR AXLE - 2.875" Inner Cone I.D. ....	- -	- -	33287 33462	3982 3920	- -	370047A -	309-0935 -	34384 34387
	REAR AXLE - 2.813" Inner Cone I.D. ....	- -	- -	33281 33462	3982 3920	TKR847 -	370001A -	308-0836 -	35066 -
<b>102</b>	REAR AXLE - STANDARD AXLE, White, & Ford Thru Ser. F90000 .....	- -	- -	- 495AX 493	- 3984 3920	- -	- 370008A -	- -	- 39380 -
	REAR AXLE - DODGE .....	-	Set408	42688 47620	39590 39520	- -	370033A -	- -	38709 -
	REAR AXLE - GMC 3.938" Shaft .....	-	Set408	495AX 493	39590 39520	TKR848 -	370024A -	309-0915 -	38750 -
	REAR AXLE - GMC 3.875" Shaft .....	-	Set408	495AX 493	39590 39520	- -	370009A -	309-0957 -	37425 39420
	REAR AXLE - FORD From Ser. F90001 .....	-	-	-	-	-	370009A	309-0957	37425 39420
	REAR AXLE - Navistar .....	Set411	Set408	47686 47620	39590 39520	TKR849 -	370023A -	309-0912 -	38780 -
<b>103</b>	REAR AXLE .....	- -	- -	493 493	- -	- -	370008A -	- -	39380 -
<b>104</b>	REAR AXLE - STANDARD AXLE .....	Set411	-	47686 47620	39585 39520	TKR849 -	370023A -	309-0912 -	38780 -
	REAR AXLE - GMC .....	Set411	Set408	47686 47620	39590 39520	TKR848 -	370024A -	309-0915 -	38750 -
	REAR AXLE - Navistar .....	Set411	Set408	47686 47620	39590 39520	TKR849 -	370023A -	309-0912 -	38780 -
<b>105</b>	REAR AXLE - STANDARD AXLE, DODGE Thru Ser. 1491999 .....	- Set402	- -	- 582 572	- 42687 42620	- -	- 370030A -	- 309-0961 -	- 42800 -
	REAR AXLE - DODGE From Ser. 1492000 .....	Set411	-	47686 47620	39585 39520	TKR849 -	370023A -	309-0912 -	38780 -

HEAVY-DUTY WHEEL BEARING APPLICATIONS

Manufacturer Line Number	Inner Set	Outer Set	Inner (Cone/Cup)	Outer (Cone/Cup)	Timken	National	Stemco	SKF

**ARVINMERITOR** (continued)

REAR AXLE - Navistar .....	Set411 -	Set408 -	47686 47620	39590 39520	TKR849 -	370023A -	309-0912 -	38780 -
<b>106</b>								
REAR AXLE - STANDARD AXLE .....	- -	- -	495AX 493	3984 3920	- -	370008A -	- -	39380 -
REAR AXLE - DODGE .....	Set411 -	Set408 -	47686 47620	39590 39520	TKR849 -	370023A -	309-0912 -	38780 -
REAR AXLE - GMC .....	Set411 -	Set408 -	47686 47620	39590 39520	TKR848 -	370024A -	309-0915 -	38750 -
<b>107</b>								
REAR AXLE .....	- -	- -	52400 52618	68462 68712	TKR859 -	370025A -	307-0743 -	46305 -
<b>108</b>								
REAR AXLE .....	- -	- -	493 493	- -	- -	370008A -	- -	39380 -
<b>109</b>								
REAR AXLE .....	- -	- -	52400 52618	68462 68712	- -	- -	- -	- -
<b>110</b>								
REAR AXLE .....	- -	- -	52400 52618	68462 68712	- -	- -	- -	- -
<b>111</b>								
REAR AXLE .....	- -	- -	34300 34478	- -	- -	- -	- -	- -
<b>112</b>								
REAR AXLE - 3.00" Outer Cone I.D. ....	- -	- -	598 592A	575 572	TKR854 -	370019A -	309-0965 -	43860 -
REAR AXLE - 3.25" Outer Cone I.D. ....	- -	Set401 -	598 592A	580 572	TKR854 -	370019A -	309-0965 -	43860 -
<b>113</b>								
REAR AXLE .....	Set405 -	Set401 -	663 653	580 572	- -	370178A -	- -	44964 -
<b>114</b>								
REAR AXLE - 4.5" Shaft .....	Set403 -	Set401 -	594A 592A	580 572	TKR858 -	370021A -	309-0964 -	45160 -
REAR AXLE - 4.82" Shaft .....	Set403 -	Set401 -	594A 592A	580 572	- -	- -	- -	- -
<b>115</b>								
REAR AXLE .....	- -	Set405 -	- -	663 653	- -	370178A -	- -	44964 -
<b>116</b>								
REAR AXLE .....	- -	- -	687 672	47890 47820	- -	370195A -	1066 3909034	48690 -
<b>117</b>								
REAR AXLE - STANDARD AXLE .....	- -	Set405 -	749A 742	663 653	- -	370178A -	- -	44964 -
REAR AXLE - GMC .....	- -	Set405 -	749A 742	663 653	- -	370178A -	- -	44964 -
<b>118</b>								
REAR AXLE - STANDARD AXLE .....	- -	- -	596 592A	596 592A	TKR850 -	370036A -	307-0713 -	40136 -

Manufacturer Line Number	Inner Set	Outer Set	Inner (Cone/Cup)	Outer (Cone/Cup)	Timken	National	Stemco	SKF

**ARVINMERITOR (continued)**

REAR AXLE - WHITE .....	-	-	596	581	TKR850	370036A	307-0713	40136
	-	-	592A	572	-	-	-	-
<b>119</b>								
REAR AXLE .....	-	-	395	387	-	-	-	-
	-	-	394A	382A	-	-	-	-
<b>120</b>								
REAR AXLE - STANDARD AXLE - 3.00" Outer Cone I.D. ....	-	-	-	-	-	-	-	-
	Set401	-	580	575	TKR850	370036A	307-0713	40136
	-	-	572	572	-	-	-	-
REAR AXLE - STANDARD AXLE - 2.62" Outer Cone I.D. ....	-	-	-	-	-	-	-	-
	Set401	-	580	553X	TKR850	370036A	307-0713	40136
	-	-	572	560	-	-	-	-
<b>121</b>								
REAR AXLE .....	Set401	-	580	-	TKR850	370036A	307-0713	40136
	-	-	572	-	-	-	-	-
<b>122</b>								
TRAILER AXLE .....	-	-	495AX	3984	-	370008A	-	39380
	-	-	493	3920	-	-	-	-
<b>123</b>								
TRAILER AXLE .....	Set405	Set413	663	HM212049	TKR850	370036A 1	307-0713	40136
	-	-	653	HM212011	-	370349A 2	307-0713	40136
<b>124</b>								
TRAILER AXLE .....	-	Set413	665A	HM212049	TKR853	370037A 1	307-0744	43752
	-	-	653	HM212011	-	370338A 2	3070744	43752
	-	-	-	-	-	-	3727095	43754
	-	-	-	-	-	-	3730144	-
<b>125</b>								
TRAILER AXLE .....	-	-	-	596	-	370004A	-	48884
	-	-	-	592A	-	-	-	-
<b>126</b>								
TRAILER AXLE .....	Set414	Set413	HM218248	HM212049	TKR859	370025A 1	307-0743	46305
	-	-	HM218210	HM212011	-	-	-	-
<b>127</b>								
TRAILER AXLE .....	Set403	Set401	594A	580	TKR861	370003A	309-0973	47697
	-	-	592A	572	-	-	-	-
<b>128</b>								
TRAILER AXLE .....	Set415	Set415	HM518445	HM518445	TKR851	370065A 1	307-0723	42623
	-	-	HM518410	HM518410	-	-	-	-
<b>129</b>								
TRAILER AXLE .....	Set403	-	594A	HM516449	TKR861	370003A	309-0973	47697
	-	-	592A	HM516410	-	-	-	-
<b>130</b>								
TRAILER AXLE .....	Set425	-	567	528	-	370013A	-	35075
	-	-	563	522	-	-	-	-
<b>131</b>								
TRAILER AXLE .....	-	-	749	643	-	370107A	-	42624
	-	-	742	632	-	-	-	-
<b>132</b>								
TRAILER AXLE .....	-	-	594	643	-	370107A	-	42624
	-	-	592A	632	-	-	-	-

1 Hub Mount 2 Spindle Mount

HEAVY-DUTY WHEEL BEARING APPLICATIONS

Manufacturer Line Number	Inner Set	Outer Set	Inner (Cone/Cup)	Outer (Cone/Cup)	Timken	National	Stemco	SKF

**ARVINMERITOR** (continued)

<b>133</b>								
TRAILER AXLE .....	Set404	-	598A	575	TKR861	370003A	309-0973	47697
	-	-	592A	572	-	-	-	-
<b>134</b>								
TRAILER AXLE - 3.67" Cup O.D. ....	Set412	-	HM212047	3779	-	370012A	-	36285
	-	-	HM212011	3720	-	-	-	-
TRAILER AXLE - 4.125" Cup O.D. ....	Set412	-	HM212047	45282	-	370012A	-	36285
	-	-	HM212011	45220	-	-	-	-

**CLARK Axle Model Index**

Model	Line No.	Model	Line No.	Model	Line No.	Model	Line No.
BD-100000 .....	4	BD-7700 .....	7	F-459 .....	2	ND7 .....	9
BD-121000 .....	5	BD-90000 .....	8	FDS-2000 .....	3	RD-22500 .....	10
BD-50-60 .....	6	F-361 .....	1	FDS-20000 .....	3		
BD-50-70 .....	6	F-362 .....	1	ND18000 .....	9		
BD-70000 .....	7	F-458 .....	2	ND20000 .....	9		

Manufacturer Line Number	Inner Set	Outer Set	Inner (Cone/Cup)	Outer (Cone/Cup)	Timken	National	Stemco	SKF

**CLARK**

<b>1</b>								
FRONT AXLE .....	-	-	2788	1380	-	-	-	-
	-	-	2726	1328	-	-	-	-
<b>2</b>								
FRONT AXLE .....	-	-	26882	15101	-	-	-	-
	-	-	26822	15250	-	-	-	-
<b>3</b>								
FRONT AXLE .....	-	-	593	56418	-	-	-	-
	-	-	592-A	56650	-	-	-	-
<b>4</b>								
BOGIE DRIVE AXLE .....	-	-	898A	67883	-	-	-	-
	-	-	892	67820	-	-	-	-
<b>5</b>								
BOGIE DRIVE AXLE .....	-	-	JM734449	JHM840449	-	-	-	-
	-	-	JM734410	JHM840410	-	-	-	-
<b>6</b>								
BOGIE DRIVE AXLE .....	-	-	685	48286	-	-	-	-
	-	-	672	48220	-	-	-	-
<b>7</b>								
BOGIE DRIVE AXLE .....	-	-	71450	67388	-	-	-	-
	-	-	71750	67322	-	-	-	-
<b>8</b>								
BOGIE DRIVE AXLE .....	-	-	67390	67782	-	-	-	-
	-	-	67320	67720	-	-	-	-
<b>9</b>								
TRAILER AXLE - w/3.25" INR BORE .....	Set405	-	663	-	TKR850	370036A 1	307-0713	40136
	-	-	653	-	-	-	-	-
TRAILER AXLE - w/3.875" INR BORE .....	-	-	685	-	-	370349A 2	307-0713	40136
	-	-	672	-	-	-	-	-
TRAILER AXLE .....	-	Set413	-	HM212049	-	-	-	-
	-	-	-	HM212011	-	-	-	-

1 Hub Mount 2 Spindle Mount

Manufacturer Line Number	Inner Set	Outer Set	Inner (Cone/Cup)	Outer (Cone/Cup)				
					Timken	National	Stemco	SKF

**CLARK (continued)**

<b>10</b>	DRIVE AXLE .....	-	-	685	48190	-	-	-	-
		-	-	672	48120	-	-	-	-

**DAVIES TRUCK EQUIPMENT LTD. Axle Model Index**

Model	Line No.	Model	Line No.	Model	Line No.	Model	Line No.
TAG AXLE .....	1						

Manufacturer Line Number	Inner Set	Outer Set	Inner (Cone/Cup)	Outer (Cone/Cup)				
					Timken	National	Stemco	SKF

**DAVIES TRUCK EQUIPMENT LTD.**

<b>1</b>	.....	Set405	Set413	663	HM212049	-	-	-	-
		-	-	653	HM212011	-	-	-	-

**DODGE Axle Model Index**

Model	Line No.	Model	Line No.	Model	Line No.	Model	Line No.
11000# .....	1	16000# .....	4	5500# .....	6	RA-115 .....	9
12000# .....	2	4000# .....	5	7000# .....	7		
15000# .....	3	5000# .....	6	9000# .....	8		

Manufacturer Line Number	Inner Set	Outer Set	Inner (Cone/Cup)	Outer (Cone/Cup)				
					Timken	National	Stemco	SKF

**DODGE**

<b>1</b>	FRONT AXLE .....	-	-	HM212044	3585	TKR847	370001A	308-0836	35066
		-	-	HM212011	3525	-	-	-	-

<b>2</b>	FRONT AXLE .....	Set412	-	HM212047	3585	TKR847	370001A	308-0836	35066
		-	-	HM212011	3525	-	-	-	-

<b>3</b>	FRONT AXLE .....	-	-	6386	537	-	370008A	-	39380
		-	-	6320	532A	-	-	-	-

<b>4</b>	FRONT AXLE .....	Set423	-	6461A	555-S	TKR863	370048A	309-0864	43764
		-	-	6420	552A	-	-	-	-
	FRONT AXLE - W/AIR OVER HYD BRKS .....	-	-	-	3979	-	370182A	-	43764
		-	-	-	3920	-	-	-	-

<b>5</b>	FRONT AXLE .....	-	-	LM603049	15101	-	-	-	-
		-	-	LM603012	15245	-	-	-	-

<b>6</b>	FRONT AXLE .....	-	-	25590	14116	-	-	-	-
		-	-	25520	14276	-	-	-	-

<b>7</b>	FRONT AXLE .....	Set410	-	45284	2780	-	370132A	308-0863	34975
		-	-	45220	2720	-	-	-	-

<b>8</b>	FRONT AXLE .....	-	-	39581	3585	-	370132A	308-0863	34975
		-	-	39520	3525	-	-	-	-

HEAVY-DUTY WHEEL BEARING APPLICATIONS

Manufacturer Line Number	Inner Set	Outer Set	Inner (Cone/Cup)	Outer (Cone/Cup)	Timken	National	Stemco	SKF

**DODGE** (continued)

<b>9</b>								
REAR AXLE .....	-	-	3984	462	-	-	-	-
	-	-	3920	453X	-	-	-	-

**DANA~ SPICER~ EATON Axle Model Index**

Model	Line No.	Model	Line No.	Model	Line No.	Model	Line No.
.....	103	17301	72	19801	74	28M SERIES	63
.....	105	17302	72	19803	74	30105	64
.....	107	17320	72	20000	55	30105S	64
1204	111	17321	72	2010	73	30127	66
1206	111	17400	72	20100	55	30327	66
1250	111	17421	72	2011	62	30427	66
1265	111	17800	72	2011	73	30D SERIES	65
1275	111	17801	72	20120	55	32M SERIES	75
1277	111	17802	72	20121	60	34D SERIES	75
13100	38	17810	72	20220	54	34M SERIES	75
13101	38	1790	48	20300	55	34R	75
1315	29	1790A	48	20320	55	35327	66
1315	111	1791	48	20500	55	36R	67
1350	31	1791A	48	20502	55	3802	111
13600	33	18100	56	20503	55	38D SERIES	68
13602	33	18101	56	20800	55	42000	55
13800	33	18120	56	20801	55	42D SERIES	69
13802	41	18121	56	20L	25	42M	71
15040S	36	18200	73	20L-77	88	44D SERIES	70
15101	38	18201	73	21080S	60	50D SERIES	70
15201	41	18202	73	21121	56	50M	71
15301	41	18220	73	21221	73	6600	46
16000	46	18221	73	21321	73	6601	46
16001	46	18300	73	21421	73	6802	46
16050	46	18301	73	21D	90	6803	46
16051	46	18302	73	22060S	57	70	3
16120	42	18320	73	22080S	60	70-HD	3
16121	42	18321	73	22121	60	70-SRWFF	5
16121	46	1880	73	22221	60	7810	72
16122	46	18800	73	22321	60	79F	2
16124	44	18802	73	22421	60	80RWFF	5
1614	43	18803	73	22501	58	82F	2
1615	43	1881	73	22L	89	8802	73
1618	46	18812	73	22M SERIES	59	8803	73
1618	46	1892	49	22R	89	8812	73
1619	46	1893	49	23080S	60	9502	74
1619	46	1900	73	23105C	84	9503	74
16220	46	19050S	50	23105S	84	A45	104
16221	46	19060S	50	23121	60	A65	106
16244	44	1910	51	23221	61	C	88
16320	46	19100	51	23321	61	C2	89
16321	46	19101	51	23421	61	CD	88
16344	44	1911	51	23L	88	CD2	89
16500	46	19120	51	23L	92	D	90
16501	46	19121	51	23L501	88	D10	100
16600	45	1918	51	23R	88	D135S	21
16601	46	1919	51	23R	92	D14	101
16800	46	19200	74	24L	88	D-340 SERIES	75
16801	46	19201	74	25LD	90	D-341 SERIES	75
16802	46	19202	74	25R	88	D-344-P	75
16803	46	19220	74	25R	89	D-380	76
17100	47	19221	74	25RD	110	D-380-P SERIES	76
17101	47	19301	52	26105S	84	D-381	79
17120	47	19321	74	26121	60	D-381-P	79
17121	47	19420	61	26221	61	D-400-P SERIES	77
17200	72	19500	74	26321	61	D-401-P	79
17201	72	19503	74	26421	61	D-402-P	79
17202	72	19512	53	26426	61	D-404-P	80
17220	72	19513	74	2750	62	D-440-P	78
17221	72	19800	74	2817	46	D-451-P SERIES	79

**DANA~ SPICER~ EATON Axle Model Index (continued)**

Model	Line No.	Model	Line No.	Model	Line No.	Model	Line No.
D-454-P SERIES	80	EST230P	110	J	92	R-380 Series	76
D-461-P	82	ETA225D	90	J175S	8	R900	109
D-480-P	81	ETA225J	91	J-190-S	12	R-909	93
D-485-P	82	ETA230C	88	J190S	17	S-135-S	21
D-521-P	82	F-155-S	7	J-210-S	12	S-150-S	21
D-550/650	86	F155S	21	J210S	17	T	88
D-580-P	87	F-170-S	8	J-220-S	14	T-11A	99
D-581-P	82	F3A	13	J-340-S	16	T-14	94
D-601-P	83	F3D	13	J340S	17	T-14D	94
D-650-P	87	F4A	15	J400S	18	T-18C	88
D-651-P	87	F4D	15	J460S	18	T-21	95
DE	90	FCA	22	J501	88	T-21D	95
DH	90	FCA-00	22	JE	88	T22L	89
DWL1	90	FE-10	24	JE	92	T23L	88
E	89	FE-10A	24	JH	88	T24L	88
E1000I	4	FE-10A43	24	JH	92	T-25	98
E1200I	4	FE-11	19	K-14	27	T-550/650	86
E23105C	84	FE-15	23	K-20	28	T-580-P	87
E23105S	84	FE-15B	23	K-22	30	T-650-P	87
E-660-G	87	FE-18	22	K-25	32	T-9	96
ED	89	FF	1	K-30	34	T9AD	108
EFA12F3	4	FK	23	K-45	35	T-9D	97
EFA-12F4	4	FTC	22	K-65	37	W	98
EFA13F3	6	FTK	23	LA-15	88	W230S	14
EFA13F4	6	FX-1	24	M-185-S/T	17	W460S	18
EFA13F5	6	FY-1	26	M-190-S/T	17	WC190S	21
EFA18F3	10	G155T	21	M200S	21	X1A	99
EFA20F4	10	G175S	17	M210T	17		
EFA22T2	10	G-175-S/T	9	M220S	21		
EFA22T5	10	G-185-S	11	M-220-S/T	18		
EFA24T2	10	G185S	17	M-230-S/T	18		
EFA24T5	10	G190S	17	M460S	14		
EH	89	G340S	17	N	94		
ESR225J	88	G380S	14	N	98		
ESR225P	110	G400S	14	ND	94		
ESR230J	88	H	95	N Trailer	39		
ESR230P	110	H25LD	90	P22	102		
EST225J	88	H25R	88	P-652-P	85		
EST225P	110	HD	95	P Trailer	40		
EST230J	88	J	88	R	20		

Manufacturer Line Number	Inner Set	Outer Set	Inner (Cone/Cup)	Outer (Cone/Cup)	Timken	National	Stemco	SKF

**DANA~ SPICER~ EATON**

<b>1</b>	FRONT AXLE	-	-	NP431952 NP378092	NP555065 NP720703	-	-	-	-
<b>2</b>	FRONT AXLE	-	-	6386 6320	535 532A	-	-	-	-
<b>3</b>	REAR AXLE	-	-	387AS 382A	LM104949 LM104911	-	-	-	-
<b>4</b>	FRONT AXLE	Set413	Set406	HM212049 HM212011	3782 3720	TKR847	370001A	308-0836	35066
<b>5</b>	REAR AXLE	Set407	-	28682 28622	LM104949 LM104910	-	-	-	-
<b>6</b>	FRONT AXLE	-	Set406	HM212049 HM212011	3782 3720	-	370012A	-	36285

HEAVY-DUTY WHEEL BEARING APPLICATIONS

Manufacturer Line Number	Inner Set	Outer Set	Inner (Cone/Cup)	Outer (Cone/Cup)	Timken	National	Stemco	SKF

**DANA~ SPICER~ EATON** (continued)

<b>7</b>								
REAR AXLE .....	-	-	33281	39585	-	370169A	-	35000
	-	-	33462	39520	-	-	-	-
<b>8</b>								
REAR AXLE - W/8.875" B.C. ....	-	-	47687	39585	TKR849	370023A	309-0912	38780
	-	-	47620	39520	-	-	-	-
REAR AXLE - W/11.25" B.C. ....	Set411	-	47686	39585	-	370165A	-	38747
	-	-	47620	39520	-	-	-	-
<b>9</b>								
REAR AXLE - G-175S/T .....	-	-	495AX	-	-	370008A	-	39380
	-	-	493	-	-	-	-	-
REAR AXLE .....	-	Set408	-	39590	TKR848	370024A	309-0915	38750
	-	-	-	39520	-	-	-	-
<b>10</b>								
FRONT AXLE .....	Set423	-	6461A	555-S	TKR863	370048A	309-0864	43764
	-	-	6420	552A	-	-	-	-
FRONT AXLE - W/AIR OVER HYD DISK BRKS .....	-	-	-	-	-	-	-	-
	-	-	-	3979	-	370182A	-	43764
	-	-	-	3920	-	-	-	-
<b>11</b>								
REAR AXLE - G-185S .....	Set411	-	47686	-	TKR849	370023A	309-0912	38780
	-	-	47620	-	-	-	-	-
REAR AXLE .....	-	Set408	-	39590	TKR848	370024A	309-0915	38750
	-	-	-	39520	-	-	-	-
<b>12</b>								
REAR AXLE .....	Set411	Set408	47686	39590	TKR848	370024A	309-0915	38750
	-	-	47620	39520	-	-	-	-
REAR AXLE - GMC .....	-	-	47687	39585	TKR848	370024A	309-0915	38750
	-	-	47620	39520	-	-	-	-
<b>13</b>								
FRONT AXLE .....	-	-	HH221442	749	-	-	-	-
	-	-	HH221410	742	-	-	-	-
<b>14</b>								
REAR AXLE .....	Set403	Set401	594A	580	TKR858	370021A	309-0964	45160
	-	-	592A	572	-	-	-	-
<b>15</b>								
FRONT AXLE .....	-	-	HH224340	749	-	-	-	-
	-	-	HH224310	742	-	-	-	-
<b>16</b>								
REAR AXLE .....	Set411	Set408	47686	39590	TKR849	370023A	309-0912	38780
	-	-	47620	39520	-	-	-	-
REAR AXLE - GMC .....	-	-	47687	39585	TKR861	370003A	309-0973	47697
	-	-	47620	39520	-	-	-	-
<b>17</b>								
REAR AXLE .....	Set411	Set408	47686	39590	TKR858	370021A	309-0964	45160
	-	-	47620	39520	-	-	-	-
<b>18</b>								
REAR AXLE .....	Set403	Set401	594A	580	TKR861	370003A	309-0973	47697
	-	-	592A	572	-	-	-	-
<b>19</b>								
FRONT AXLE .....	-	-	637	527	-	-	-	-
	-	-	633	522	-	-	-	-

Manufacturer Line Number	Inner Set	Outer Set	Inner (Cone/Cup)	Outer (Cone/Cup)	Timken	National	Stemco	SKF

**DANA~ SPICER~ EATON (continued)**

<b>20</b>	REAR AXLE .....	-	-	NP568900 NP107783	NP555065 NP975161	-	-	-	-
<b>21</b>	REAR AXLE .....	-	-	33287 33462	39585 39520	-	370169A	-	35000
<b>22</b>	FRONT AXLE .....	-	-	843 832	636 632	-	-	-	-
<b>23</b>	FRONT AXLE .....	-	-	6460 6420	636 632	-	-	-	-
<b>26</b>	FRONT AXLE .....	-	-	584 5535	527 522	-	-	-	-
<b>27</b>	TRAILER AXLE .....	Set425	-	567 563	528 522	-	-	-	-
<b>28</b>	TRAILER AXLE .....	Set405	Set413	663 653	HM212049 HM212011	TKR850	370036A	307-0713	40136
<b>29</b>	REAR AXLE - STD .....	-	-	33281 33462	3982 3920	-	370047A	309-0935	34384 34387
	REAR AXLE - CAN .....	-	-	33287 33462	3982 3920	-	-	-	-
<b>30</b>	TRAILER AXLE .....	Set414	Set413	HM218248 HM218210	HM212049 HM212011	TKR859	370025A	307-0743	46305
<b>31</b>	REAR AXLE - DIAMOND T, DODGE, FORD, GMC .....	-	-	- 33281 33462	- 3982 3920	-	-	-	-
	REAR AXLE - IHC .....	Set411	Set408	47686 47620	39590 39520	-	-	-	-
<b>32</b>	TRAILER AXLE .....	-	-	749 742	643 632	-	-	-	-
	TRAILER AXLE - OPT .....	-	-	-	643 633	-	-	-	-
<b>33</b>	REAR AXLE - DODGE & FORD .....	-	-	33287 33462	3982 3920	-	370047A	309-0935	34384 34387
	REAR AXLE - WHITE .....	-	-	3984 3920	29585 29520	-	-	-	-
<b>34</b>	TRAILER AXLE .....	-	-	759 752	740 742	-	370192A	-	45162
<b>35</b>	TRAILER AXLE .....	-	-	780 772	6580 6535	-	-	-	-

HEAVY-DUTY WHEEL BEARING APPLICATIONS

Manufacturer Line Number	Inner Set	Outer Set	Inner (Cone/Cup)	Outer (Cone/Cup)	Timken	National	Stemco	SKF

**DANA~ SPICER~ EATON** (continued)

<b>36</b>								
REAR AXLE .....	-	-	33287	3982	-	370008A	-	39380
	-	-	33462	3920	-	-	-	-
<b>37</b>								
TRAILER AXLE .....	-	-	896	6580	-	-	-	-
	-	-	892	6535	-	-	-	-
<b>38</b>								
REAR AXLE .....	-	-	33287	3982	-	370008A	-	39380
	-	-	33462	3920	-	-	-	-
<b>39</b>								
TRAILER AXLE .....	-	-	NP022333	NP431952	-	-	-	-
	-	-	NP250023	NP378092	-	-	-	-
<b>40</b>								
TRAILER AXLE .....	-	-	NP417549	NP417549	-	-	-	-
	-	-	NP156827	NP156827	-	-	-	-
<b>41</b>								
REAR AXLE - STD .....	-	-	33287	3982	-	-	-	-
	-	-	33462	3920	-	-	-	-
REAR AXLE - IHC-W/RA-126 .....	-	-	3984	29585	-	-	-	-
	-	-	3920	29520	-	-	-	-
REAR AXLE - IHC-W/RA-127 & WHITE .....	-	-	33281	39585	-	-	-	-
	-	-	33462	39520	-	-	-	-
<b>42</b>								
REAR AXLE - STD .....	-	Set408	495AX	39590	-	370009A	309-0957	37425
	-	-	493	39520	-	-	-	39420
<b>43</b>								
REAR AXLE - BROCKWAY .....	-	-	42688	3984	-	370033A	-	38709
	-	-	42620	3920	-	-	-	-
REAR AXLE - DIAMOND T & IHC .....	-	-	42688	39585	-	370033A	-	38709
	-	-	42620	39520	-	-	-	-
REAR AXLE - DODGE .....	-	Set408	42688	39590	-	370033A	-	38709
	-	-	42620	39520	-	-	-	-
REAR AXLE - FORD .....	-	-	495AX	3984	-	-	-	-
	-	-	493	3920	-	-	-	-
REAR AXLE - GMC .....	-	Set408	495AX	39590	-	-	-	-
	-	-	493	39520	-	-	-	-
<b>44</b>								
REAR AXLE - STD .....	-	Set408	495AX	39590	-	-	-	-
	-	-	493	39520	-	-	-	-
REAR AXLE - DIAMOND T .....	-	-	42688	39585	-	370033A	-	38709
	-	-	42620	39520	-	-	-	-
REAR AXLE - DODGE .....	-	Set408	42688	39590	-	370033A	-	38709
	-	-	42620	39520	-	-	-	-
REAR AXLE - FORD .....	-	-	495AX	3984	-	-	-	-
	-	-	493	3920	-	-	-	-
<b>45</b>								
REAR AXLE - STD .....	-	-	42688	39585	-	370008A	-	39380
	-	-	42620	39520	-	-	-	-
REAR AXLE - CHEV, GMC & WHITE .....	-	Set408	495AX	39590	-	370008A	-	39380
	-	-	493	39520	-	-	-	-
REAR AXLE - FORD .....	-	-	495AX	3984	-	370008A	-	39380
	-	-	493	3920	-	-	-	-
<b>46</b>								
REAR AXLE - STD .....	-	Set408	495AX	39590	-	-	-	-
	-	-	493	39520	-	-	-	-

Manufacturer Line Number	Inner Set	Outer Set	Inner (Cone/Cup)	Outer (Cone/Cup)	Timken	National	Stemco	SKF

**DANA~ SPICER~ EATON (continued)**

REAR AXLE - DIAMOND T & IHC W/RA-136 .	-	-	42688	39585	-	370033A	-	38709
	-	-	42620	39520	-	-	-	-
REAR AXLE - DODGE .....	-	Set408	42688	39590	-	370033A	-	38709
	-	-	42620	39520	-	-	-	-
REAR AXLE - IHC W/RA-149/189 .....	-	-	47678	39585	-	-	-	-
	-	-	47620	39520	-	-	-	-
<b>47</b>								
REAR AXLE - STD .....	Set411	Set408	47686	39590	TKR849	370023A	309-0912	38780
	-	-	47620	39520	-	-	-	-
<b>48</b>								
REAR AXLE - STD .....	Set411	Set408	47686	39590	TKR849	370023A	309-0912	38780
	-	-	47620	39520	-	-	-	-
<b>49</b>								
REAR AXLE - STD .....	-	-	598	575	TKR849	370023A	309-0912	38780
	-	-	592A	572	-	-	-	-
<b>50</b>								
REAR AXLE .....	Set411	Set408	47686	39590	-	-	-	-
	-	-	47620	39520	-	-	-	-
<b>51</b>								
REAR AXLE - STD .....	-	Set401	594	580	TKR858	370021A	309-0964	45160
	-	-	592A	572	-	-	-	-
REAR AXLE - FORD 4-76 ON .....	Set403	Set401	594A	580	TKR858	370021A	309-0964	45160
	-	-	592A	572	-	-	-	-
<b>52</b>								
REAR AXLE - STD .....	-	Set401	594	580	TKR858	370021A	309-0964	45160
	-	-	592A	572	-	-	-	-
REAR AXLE - FORD 4-76 ON .....	Set403	Set401	594A	580	TKR858	370021A	309-0964	45160
	-	-	592A	572	-	-	-	-
REAR AXLE - PETERBILT, 19301/420 .....	Set404	Set401	598A	580	TKR860	370005A	309-0960	48000
	-	-	592A	572	-	-	-	-
<b>53</b>								
REAR AXLE - STD .....	-	Set401	594	580	TKR858	370021A	309-0964	45160
	-	-	592A	572	-	-	-	-
REAR AXLE - FORD 4-76 ON .....	Set403	Set401	594A	580	TKR858	370021A	309-0964	45160
	-	-	592A	572	-	-	-	-
REAR AXLE - IHC .....	Set403	Set401	594A	580	TKR858	370021A	309-0964	45160
	-	-	592A	572	-	-	-	-
<b>54</b>								
REAR AXLE - STD .....	-	-	663	663	TKR852	370031A	309-0904	42672
	-	-	652	652	-	-	-	-
<b>55</b>								
REAR AXLE - STD .....	-	-	663	663	TKR852	370031A	309-0904	42672
	-	-	652	652	-	-	-	-
REAR AXLE - IHC-SOME .....	-	Set402	595	582	TKR852	370031A	309-0904	42672
	-	-	592A	572	-	-	-	-
<b>56</b>								
REAR AXLE - STD; THRU 4-76 .....	-	-	598	575	TKR860	370005A	309-0960	48000
	-	-	592A	572	-	-	-	-
REAR AXLE - STD; 5-76 ON .....	Set403	Set401	594A	580	TKR858	370021A	309-0964	45160
	-	-	592A	572	-	-	-	-
REAR AXLE - DODGE .....	Set404	-	598A	575	TKR860	370005A	309-0960	48000
	-	-	592A	572	-	-	-	-
<b>57</b>								
REAR AXLE .....	-	Set401	394A	580	-	-	-	-
	-	-	392A	572	-	-	-	-

HEAVY-DUTY WHEEL BEARING APPLICATIONS

Manufacturer Line Number	Inner Set	Outer Set	Inner (Cone/Cup)	Outer (Cone/Cup)	Timken	National	Stemco	SKF

**DANA~ SPICER~ EATON** (continued)

<b>58</b>	REAR AXLE - STD .....	-	-	760	665	-	370121A	-	48884
		-	-	752	652	-	-	-	-
	REAR AXLE - GMC & IHC-SOME .....	-	-	760	749	-	370121A	-	48884
		-	-	752	742	-	-	-	-
<b>59</b>	TANDEM REAR AXLE - FORD .....	-	-	33281	3982	-	370047A	309-0935	34384
		-	-	33462	3920	-	-	-	34387
	TANDEM REAR AXLE - EXC FORD .....	-	-	33281	39585	-	370047A	309-0935	34384
		-	-	33462	39520	-	-	-	34387
<b>60</b>	REAR AXLE .....	Set403	Set401	594A	580	-	-	-	-
		-	-	592A	572	-	-	-	-
<b>61</b>	REAR AXLE - THRU 4-76 .....	-	-	594	-	TKR858	370021A	309-0964	45160
		-	-	592A	-	-	-	-	-
	REAR AXLE - 5-76 ON .....	Set403	-	594A	-	TKR858	370021A	309-0964	45160
		-	-	592A	-	-	-	-	-
	REAR AXLE .....	-	Set401	-	580	-	-	-	-
		-	-	-	572	-	-	-	-
<b>62</b>	REAR AXLE - STD .....	-	-	663	663	TKR854	370019A	309-0965	43860
		-	-	652	652	-	-	-	-
<b>63</b>	TANDEM REAR AXLE - DIAMOND T, IHC, REO & WHITE .....	-	-	-	-	-	-	-	-
		-	-	42688	39585	-	370033A	-	38709
		-	-	42620	39520	-	-	-	-
	TANDEM REAR AXLE - DODGE .....	-	Set408	42688	39590	-	370033A	-	38709
		-	-	42620	39520	-	-	-	-
	TANDEM REAR AXLE - FORD .....	-	-	495AX	3984	-	370033A	-	38709
		-	-	493	3920	-	-	-	-
	TANDEM REAR AXLE - GMC .....	-	Set408	495AX	39590	-	370033A	-	38709
		-	-	493	39520	-	-	-	-
<b>64</b>	REAR AXLE .....	-	-	782	6580	-	-	-	-
		-	-	772	6535	-	-	-	-
<b>65</b>	TANDEM REAR AXLE - CHEV & GMC .....	-	Set408	495AX	39590	-	370033A	-	38709
		-	-	493	39520	-	-	-	-
	TANDEM REAR AXLE - DIAMOND T & FORD	-	-	495AX	3984	-	370033A	-	38709
		-	-	493	3920	-	-	-	-
	TANDEM REAR AXLE - DODGE .....	-	Set408	42688	39590	-	370033A	-	38709
		-	-	42620	39520	-	-	-	-
	TANDEM REAR AXLE - IHC & WHITE .....	-	-	42688	39585	-	370033A	-	38709
		-	-	42620	39520	-	-	-	-
<b>66</b>	REAR AXLE .....	-	-	760	749	-	-	-	-
		-	-	752	742	-	-	-	-
<b>67</b>	TANDEM REAR AXLE - IHC .....	-	-	5760	575	TKR849	370023A	309-0912	38780
		-	-	5735	572	-	-	-	-
<b>68</b>	TANDEM REAR AXLE - THRU 4-76 .....	-	-	598	575	TKR860	370005A	309-0960	48000
		-	-	592A	572	-	-	-	-

Manufacturer Line Number	Inner Set	Outer Set	Inner (Cone/Cup)	Outer (Cone/Cup)	Timken	National	Stemco	SKF

**DANA~ SPICER~ EATON (continued)**

TANDEM REAR AXLE - 5-76 ON .....	Set403 -	Set401 -	594A 592A	580 572	TKR858 -	370021A -	309-0964 -	45160 -
TANDEM REAR AXLE - FORD 4-76 ON .....	Set403 -	Set401 -	594A 592A	580 572	TKR858 -	370021A -	309-0964 -	45160 -
<b>69</b> TANDEM REAR AXLE .....	- -	Set401 -	595 592A	580 572	TKR854 -	370019A -	309-0965 -	43860 -
<b>70</b> TANDEM REAR AXLE - THRU 4-76 .....	- -	- -	594 592A	- -	TKR858 -	370021A -	309-0964 -	45160 -
TANDEM REAR AXLE - 5-76 ON .....	Set403 -	- -	594A 592A	- -	TKR858 -	370021A -	309-0964 -	45160 -
TANDEM REAR AXLE .....	- -	Set401 -	- -	580 572	TKR858 -	370021A -	309-0964 -	45160 -
<b>71</b> TANDEM REAR AXLE .....	- -	- -	760 752	749 742	- -	370004A -	- -	48884 -
<b>72</b> REAR AXLE - STD .....	Set411 -	Set408 -	47686 47620	39590 39520	TKR849 -	370023A -	309-0912 -	38780 -
<b>73</b> REAR AXLE - STD & FORGED HUB; THRU 4-76 .....	- -	- -	- 598 592A	- 575 572	- - -	- - -	- - -	- - -
REAR AXLE - CAST HUB; THRU 4-76 .....	- -	- -	575 572	575 572	TKR854 -	370019A -	309-0965 -	43860 -
REAR AXLE - STD; 5-76 ON .....	Set403 -	Set401 -	594A 592A	580 572	TKR854 -	370019A -	309-0965 -	43860 -
REAR AXLE - DODGE .....	Set404 -	- -	598A 592A	575 572	TKR854 -	370019A -	309-0965 -	43860 -
<b>74</b> REAR AXLE - STD .....	- -	Set401 -	594 592A	580 572	TKR858 -	370021A -	309-0964 -	45160 -
REAR AXLE - FORD 4-76 ON .....	Set403 -	Set401 -	594A 592A	580 572	TKR858 -	370021A -	309-0964 -	45160 -
<b>75</b> TANDEM REAR AXLE .....	Set411 -	Set408 -	47686 47620	39590 39520	TKR849 -	370023A -	309-0912 -	38780 -
<b>76</b> TANDEM REAR AXLE - THRU 1977 .....	- -	- -	598 592A	575 572	TKR854 -	370019A -	309-0965 -	43860 -
TANDEM REAR AXLE - 1978 ON .....	Set403 -	Set401 -	594A 592A	580 572	TKR854 -	370019A -	309-0965 -	43860 -
<b>77</b> TANDEM REAR AXLE - THRU 1977 .....	- -	- -	594 592A	- -	- -	- -	- -	- -
TANDEM REAR AXLE - 1978 ON .....	Set403 -	- -	594A 592A	- -	- -	- -	- -	- -
TANDEM REAR AXLE .....	- -	Set401 -	- -	580 572	- -	- -	- -	- -
<b>78</b> TANDEM REAR AXLE .....	Set403 -	- -	594A 592A	- -	TKR858 -	370021A -	309-0964 -	45160 -

HEAVY-DUTY WHEEL BEARING APPLICATIONS

Manufacturer Line Number	Inner Set	Outer Set	Inner (Cone/Cup)	Outer (Cone/Cup)	Timken	National	Stemco	SKF

**DANA~ SPICER~ EATON** (continued)

<b>79</b>								
TANDEM REAR AXLE .....	Set403	Set401	594A	580	-	-	-	-
	-	-	592A	572	-	-	-	-
<b>80</b>								
TANDEM REAR AXLE .....	-	Set401	-	580	-	-	-	-
	-	-	-	572	-	-	-	-
<b>81</b>								
TANDEM REAR AXLE - THRU 1979 .....	-	-	594	-	TKR858	370021A	309-0964	45160
	-	-	592A	-	-	-	-	-
TANDEM REAR AXLE - 1980 ON .....	Set403	-	594A	-	TKR858	370021A	309-0964	45160
	-	-	592A	-	-	-	-	-
TANDEM REAR AXLE .....	-	Set401	-	580	TKR858	370021A	309-0964	45160
	-	-	-	572	-	-	-	-
<b>82</b>								
TANDEM REAR AXLE .....	Set403	Set401	594A	580	-	-	-	-
	-	-	592A	572	-	-	-	-
<b>83</b>								
TANDEM REAR AXLE .....	-	-	782	6580	-	-	-	-
	-	-	772	6535	-	-	-	-
<b>84</b>								
REAR AXLE .....	Set403	Set401	594A	580	TKR849	370023A	309-0912	38780
	-	-	592A	572	-	-	-	-
<b>85</b>								
TANDEM REAR AXLE .....	Set403	-	594A	-	-	-	-	-
	-	-	592A	-	-	-	-	-
<b>86</b>								
TANDEM REAR AXLE .....	-	-	760	749	-	-	-	-
	-	-	752	742	-	-	-	-
<b>87</b>								
TANDEM REAR AXLE .....	-	-	760	749	-	-	-	-
	-	-	752	742	-	-	-	-
<b>88</b>								
TRAILER AXLE .....	Set414	Set413	HM218248	HM212049	TKR859	370025A 1	307-0743	46305
	-	-	HM218210	HM212011	-	-	-	-
<b>89</b>								
TRAILER AXLE .....	-	Set413	665A	HM212049	TKR853	370037A	307-0744	43752
	-	-	653	HM212011	-	-	-	-
<b>90</b>								
TRAILER AXLE .....	Set403	Set401	594A	580	TKR861	370003A	309-0973	47697
	-	-	592A	572	-	-	-	-
<b>91</b>								
TRAILER AXLE .....	Set414	Set413	HM218248	HM212049	TKR850	370036A	307-0713	40136
	-	-	HM218210	HM212011	-	-	-	-
<b>92</b>								
TRAILER AXLE .....	Set414	Set413	HM218248	HM212049	TKR859	370025A	307-0743	46305
	-	-	HM218210	HM212011	-	-	-	-
<b>93</b>								
TRAILER AXLE .....	-	-	593	65390	-	-	-	-
	-	-	592A	65320	-	-	-	-

1 Hub Mount

Manufacturer Line Number	Inner Set	Outer Set	Inner (Cone/Cup)	Outer (Cone/Cup)	Timken	National	Stemco	SKF

**DANA~ SPICER~ EATON (continued)**

<b>94</b>	TRAILER AXLE .....	Set425 -	- -	567 563	528 522	- -	370002A -	- -	35075 -
<b>95</b>	TRAILER AXLE .....	- -	- -	749 742	643 632	- -	370107A -	- -	42624 -
<b>96</b>	TRAILER AXLE .....	- -	Set406 -	HM212044 HM212011	3782 3720	TKR847 -	370001A -	308-0836 -	35066 -
<b>97</b>	TRAILER AXLE .....	- -	Set406 -	557A 553X	3782 3720	TKR858 -	370021A -	309-0964 -	45160 -
<b>98</b>	TRAILER AXLE .....	- -	- -	760 752	749 742	- -	370004A -	- -	48884 -
<b>100</b>	TRAILER AXLE .....	- -	- -	28995 28920	25580 25523	- -	370010A -	- -	28820 -
<b>101</b>	TRAILER AXLE .....	Set425 -	- -	567 563	522 528	- -	370002A -	- -	35075 -
<b>102</b>	TRAILER AXLE .....	Set415 -	Set415 -	HM518445 HM518410	HM518445 HM518410	TKR851 -	370065A -	307-0723 -	42623 -
<b>103</b>	TRAILER AXLE .....	- -	- -	896 892	6580 6535	- -	- -	- -	- -
<b>104</b>	TRAILER AXLE .....	- -	- -	787 772	6580 6535	- -	- -	- -	- -
<b>105</b>	TRAILER AXLE .....	- -	Set406 -	557A 553X	3782 3720	TKR858 -	370021A -	309-0964 -	45160 -
<b>106</b>	TRAILER AXLE .....	- -	- -	896 892	6580 6535	- -	- -	- -	- -
<b>107</b>	TRAILER AXLE .....	- -	- -	593 592A	65390 65320	- -	- -	- -	- -
<b>108</b>	TRAILER AXLE .....	- -	Set406 -	557A 553X	3782 3720	TKR858 -	370021A -	309-0964 -	45160 -
<b>109</b>	TRAILER AXLE .....	- -	- -	593 592A	65390 65320	- -	- -	- -	- -
<b>110</b>	TRAILER AXLE .....	Set415 -	Set415 -	HM518445 HM518410	HM518445 HM518410	TKR851 -	370065A -	307-0723 -	42623 -

HEAVY-DUTY WHEEL BEARING APPLICATIONS

Manufacturer Line Number	Inner Set	Outer Set	Inner (Cone/Cup)	Outer (Cone/Cup)	Timken	National	Stemco	SKF

**DANA~ SPICER~ EATON (continued)**

<b>111</b>								
REAR AXLE - FORD .....	-	-	33281	-	-	370047A	309-0935	34384
	-	-	33462	-	-	-	-	34387
REAR AXLE - IHC .....	-	-	33281	-	-	-	-	-
	-	-	33462	-	-	-	-	-
REAR AXLE - WHITE .....	-	-	33281	-	-	-	-	-
	-	-	33462	-	-	-	-	-

**FORD Axle Model Index**

Model	Line No.	Model	Line No.	Model	Line No.	Model	Line No.
10000# .....	1	20000# .....	2	7000# .....	6	7500# HYD .....	10
12000# .....	1	5000# .....	3	7000# .....	7	8000# .....	11
16000# .....	2	5500# .....	4	7000# HYD .....	8	9000# .....	12
18000# .....	2	6000# .....	5	7500# .....	9	9000# .....	13

Manufacturer Line Number	Inner Set	Outer Set	Inner (Cone/Cup)	Outer (Cone/Cup)	Timken	National	Stemco	SKF

**FORD**

<b>1</b>								
FRONT AXLE .....	Set412	Set406	HM212047	3782	-	370132A	308-0863	34975
	-	-	HM212011	3720	-	-	-	-
<b>2</b>								
FRONT AXLE .....	Set423	-	6461A	555-S	-	370182A	-	43764
	-	-	6420	552A	-	-	-	-
<b>3</b>								
FRONT AXLE .....	-	-	25590	25877	-	-	-	-
	-	-	25520	25820	-	-	-	-
<b>4</b>								
FRONT AXLE .....	-	-	3778	25877	-	-	-	-
	-	-	3720	25820	-	-	-	-
<b>5</b>								
FRONT AXLE - 66-67 .....	-	-	3778	25877	-	370054A	-	28832
	-	-	3720	25820	-	-	-	-
FRONT AXLE - 1968 On .....	Set410	-	45284	25880	-	370054A	-	28832
	-	-	45220	25820	-	-	-	-
<b>6</b>								
FRONT AXLE - Thru 1975 .....	Set410	-	45284	25880	-	370054A	-	28832
	-	-	45220	25820	-	-	-	-
FRONT AXLE - 1976 On w/Air Brakes .....	-	-	-	3585	-	-	-	-
	-	-	-	3525	-	-	-	-
<b>7</b>								
FRONT AXLE - 1976 On w/Air Brakes .....	-	-	39581	-	-	-	-	-
	-	-	39520	-	-	-	-	-
<b>8</b>								
FRONT AXLE - Thru 1975 .....	Set410	-	45284	25880	-	370054A	-	28832
	-	-	45220	25820	-	-	-	-
FRONT AXLE - 1976 On .....	Set410	-	45284	25880	-	370054A	-	28832
	-	-	45220	25820	-	-	-	-
<b>9</b>								
FRONT AXLE - 1976 On .....	-	-	39581	3585	-	-	-	-
	-	-	39520	3525	-	-	-	-

Manufacturer Line Number	Inner Set	Outer Set	Inner (Cone/Cup)	Outer (Cone/Cup)				
					Timken	National	Stemco	SKF

**FORD (continued)**

<b>10</b>	FRONT AXLE - Thru 1975 .....	Set410	-	45284	25880	-	370054A	-	28832
		-	-	45220	25820	-	-	-	-
<b>11</b>	FRONT AXLE - Thru 1975 .....	Set410	-	45284	25880	-	370054A	-	28832
		-	-	45220	25820	-	-	-	-
	FRONT AXLE - 1976 On w/Hyd Brakes .....	-	-	39581	3585	-	370054A	-	28832
		-	-	39520	3525	-	-	-	-
<b>12</b>	FRONT AXLE - Thru 1975 .....	Set410	-	45284	25880	TKR847	370001A	308-0836	35066
		-	-	45220	25820	-	-	-	-
	FRONT AXLE - 1976 On w/Air or Hyd Brakes ..	-	-	39581	3585	-	370132A	308-0863	34975
		-	-	39520	3525	-	-	-	-
<b>13</b>	FRONT AXLE - AIR & HYD BRKS .....	-	-	39581	3585	-	370132A	308-0863	34975
		-	-	39520	3525	-	-	-	-

**FRUEHAUF Axle Model Index**

Model	Line No.	Model	Line No.	Model	Line No.	Model	Line No.
NO. 5 .....	1	PRO-PAR .....	2				

Manufacturer Line Number	Inner Set	Outer Set	Inner (Cone/Cup)	Outer (Cone/Cup)				
					Timken	National	Stemco	SKF

**FRUEHAUF**

<b>1</b>	TRAILER AXLE .....	-	-	593	HH506348	TKR851	370065A	307-0723	42623
		-	-	592A	HH506310	-	-	-	-
<b>2</b>	TRAILER AXLE .....	Set415	Set415	HM518445	HM518445	-	-	-	-
		-	-	HM518410	HM518410	-	-	-	-

**FRUEHAUF CANADA INC. Axle Model Index**

Model	Line No.	Model	Line No.	Model	Line No.	Model	Line No.
NO. 5 .....	1	R-S TK-570 & S-F A-19S .....	2				

Manufacturer Line Number	Inner Set	Outer Set	Inner (Cone/Cup)	Outer (Cone/Cup)				
					Timken	National	Stemco	SKF

**FRUEHAUF CANADA INC.**

<b>1</b>	.....	-	-	593	HH506348	TKR851	370065A	307-0723	42623
		-	-	592A	HH506310	-	-	-	-
<b>2</b>	.....	Set405	Set413	663	HM212049	-	-	-	-
		-	-	653	HM212011	-	-	-	-

**FWD Axle Model Index**

Model	Line No.	Model	Line No.	Model	Line No.	Model	Line No.
22 .....	1	2621 .....	2	2SCB .....	4	33 .....	8
22A .....	1	2A .....	3	2SDC .....	4	33A .....	8
22HD .....	1	2B .....	4	32 .....	4	3A .....	9
23 .....	7	2C .....	4	32A .....	4	3B .....	10
23L .....	7	2SC .....	4	32R .....	4	3C .....	10

**FWD Axle Model Index (continued)**

Model	Line No.	Model	Line No.	Model	Line No.	Model	Line No.
3D	11	6-23	15	ND-22	5		
3SC	12	6-23L	15	ND-32	6		
3SCB	12	6-33	16	ND-32A	6		
3SD	13	6-33AR	16				
3SDC	13	6-33ART	16				
5644	14	6-33H	16				

Manufacturer Line Number	Inner Set	Outer Set	Inner (Cone/Cup)	Outer (Cone/Cup)	Timken	National	Stemco	SKF

**FWD**

<b>1</b>	FRONT AXLE	Set425	-	567	33275	-	-	-	-
		-	-	563	33462	-	-	-	-
<b>2</b>	FRONT AXLE	-	Set411	749	47686	-	-	-	-
		-	-	742	47620	-	-	-	-
<b>3</b>	FRONT AXLE	Set425	-	567	33275	-	-	-	-
		-	-	563	33462	-	-	-	-
<b>4</b>	FRONT AXLE	-	Set411	749	47686	-	-	-	-
		-	-	742	47620	-	-	-	-
<b>5</b>	FRONT AXLE	Set425	-	567	33275	-	-	-	-
		-	-	563	33462	-	-	-	-
<b>6</b>	FRONT AXLE	-	Set411	749	47686	-	-	-	-
		-	-	742	47620	-	-	-	-
<b>7</b>	REAR AXLE	-	-	644	644	-	-	-	-
		-	-	633	633	-	-	-	-
<b>8</b>	REAR AXLE	-	-	749	749	-	-	-	-
		-	-	742	742	-	-	-	-
<b>9</b>	REAR AXLE	-	-	29685	29685	-	-	-	-
		-	-	29620	29620	-	-	-	-
<b>10</b>	REAR AXLE	-	-	595	581	-	-	-	-
		-	-	592A	572	-	-	-	-
<b>11</b>	REAR AXLE	-	-	749	749	-	-	-	-
		-	-	742	742	-	-	-	-
<b>12</b>	REAR AXLE	-	-	595	581	-	-	-	-
		-	-	592A	572	-	-	-	-
<b>13</b>	REAR AXLE	-	-	749	749	-	-	-	-
		-	-	742	742	-	-	-	-
<b>14</b>	REAR AXLE	-	-	595	581	-	-	-	-
		-	-	592A	572	-	-	-	-

Manufacturer Line Number	Inner Set	Outer Set	Inner (Cone/Cup)	Outer (Cone/Cup)	Timken	National	Stemco	SKF

**FWD (continued)**

<b>15</b>	REAR AXLE .....	-	-	644	644	-	-	-	-
		-	-	633	633	-	-	-	-
<b>16</b>	REAR AXLE .....	-	-	749	749	-	-	-	-
		-	-	742	742	-	-	-	-

**GMC Axle Model Index**

Model	Line No.	Model	Line No.	Model	Line No.	Model	Line No.
F-040 (4000 #) .....	1	F-090 (9000#) .....	4	FD-070 .....	7	H-170 .....	10
F-045 (4500#) .....	2	F-110 .....	5	H-110 (11,000#) .....	8	T-150 (15,000#) .....	11
F-050 (5000#) .....	2	F-120 .....	5	H-130 .....	9	T-170 (17,000#) .....	12
F-055 (5500#) .....	2	F-150 .....	6	H-135 .....	9		
F-070 (7000#) .....	3	F-160 .....	6	H-150 .....	10		

Manufacturer Line Number	Inner Set	Outer Set	Inner (Cone/Cup)	Outer (Cone/Cup)	Timken	National	Stemco	SKF

**GMC**

<b>1</b>	FRONT AXLE - GMC, 66-67 .....	-	-	2777	-	-	-	-
		-	-	2720	-	-	-	-
	FRONT AXLE - CHEV; GMC, 68-69 .....	-	-	25582	-	-	-	-
		-	-	25520	-	-	-	-
	FRONT AXLE .....	-	-	-	M12649	-	-	-
		-	-	-	M12610	-	-	-
<b>2</b>	FRONT AXLE .....	-	-	3578A	15103S	-	-	-
		-	-	3525	15243	-	-	-
<b>3</b>	FRONT AXLE .....	Set410	-	45284	2796	-	370145A	31175
		-	-	45220	2720	-	-	-
<b>4</b>	FRONT AXLE .....	-	-	39581	26878	-	370018A	32470
		-	-	39520	26820	-	-	-
<b>5</b>	FRONT AXLE .....	Set412	-	HM212047	-	-	370012A	36285
		-	-	HM212011	-	-	-	-
	FRONT AXLE - 66-67 .....	-	-	-	3779	-	370012A	36285
		-	-	-	3720	-	-	-
	FRONT AXLE - 1968 ON .....	-	-	-	45282	-	370012A	36285
		-	-	-	45220	-	-	-
<b>6</b>	FRONT AXLE .....	-	-	6386A	537	-	370015A	40040
		-	-	6320	532A	-	-	-
<b>7</b>	FRONT DRIVE AXLE .....	-	-	36690	36690	-	-	-
		-	-	36620	36620	-	-	-
<b>8</b>	REAR AXLE .....	-	-	395CS	-	-	370046A	31307
		-	-	394CS	-	-	-	-

HEAVY-DUTY WHEEL BEARING APPLICATIONS

Manufacturer Line Number	Inner Set	Outer Set	Inner (Cone/Cup)	Outer (Cone/Cup)	Timken	National	Stemco	SKF

**GMC (continued)**

REAR AXLE - 1966 .....	-	-	-	388A	-	370046A	-	31307
	-	-	-	382	-	-	-	-
REAR AXLE - 1967 .....	-	-	-	388A	-	370046A	-	31307
	-	-	-	382	-	-	-	-
REAR AXLE - 1968 ON .....	-	-	-	395CS	-	370046A	-	31307
	-	-	-	394CS	-	-	-	-

**9**

REAR AXLE .....	-	-	395CS	388A	-	370046A	-	31307
	-	-	394CS	382	-	-	-	-

**10**

REAR AXLE .....	-	-	M514546	M111048	-	-	-	-
	-	-	M514512	M111012	-	-	-	-

**11**

REAR AXLE - 1966, wo/15" BRKS .....	-	-	M514546	M111048	-	370106A	-	42550
	-	-	M514512	M111012	-	-	-	-
REAR AXLE - CHEV .....	-	-	33287	3982	-	370106A	-	42550
	-	-	33472	3925	-	-	-	-
REAR AXLE - GMC, 1966 .....	-	-	33287	3982	-	370106A	-	42550
	-	-	33472	3925	-	-	-	-
REAR AXLE - 1967 ON .....	-	-	33281	-	-	370106A	-	42550
	-	-	33472	-	-	-	-	-
REAR AXLE - GMC, 1967 ON .....	-	-	-	3984	-	370106A	-	42550
	-	-	-	3925	-	-	-	-

**12**

REAR AXLE .....	-	Set408	495AX	39590	-	370106A	-	42550
	-	-	493	39520	-	-	-	-

**HAYES-DANA INC. Axle Model Index**

Model	Line No.	Model	Line No.	Model	Line No.	Model	Line No.
K-14 SERIES .....	1	K-21 Series .....	4	K-22 SERIES .....	5	K-30 SERIES .....	7
K-20 .....	2	K-21 SERIES .....	3	K-25 SERIES .....	6		

Manufacturer Line Number	Inner Set	Outer Set	Inner (Cone/Cup)	Outer (Cone/Cup)	Timken	National	Stemco	SKF

**HAYES-DANA INC.**

**1**

TRAILER AXLE .....	Set425	-	567	528	-	-	-	-
	-	-	563	522	-	-	-	-

**2**

TRAILER AXLE .....	Set405	Set413	663	HM212049	-	-	-	-
	-	-	653	HM212011	-	-	-	-

**3**

TRAILER AXLE .....	Set405	Set413	663	HM212049	-	-	-	-
	-	-	653	HM212011	-	-	-	-

**4**

TRAILER AXLE .....	Set405	Set413	663	HM212049	-	-	-	-
	-	-	653	HM212011	-	-	-	-

**5**

TRAILER AXLE .....	Set414	Set413	HM218248	HM212049	TKR859	370025A	307-0743	46305
	-	-	HM218210	HM212011	-	-	-	-

**6**

TRAILER AXLE .....	-	-	749	643	-	-	-	-
	-	-	742	632	-	-	-	-

Manufacturer Line Number	Inner Set	Outer Set	Inner (Cone/Cup)	Outer (Cone/Cup)	Timken	National	Stemco	SKF

**HAYES-DANA INC. (continued)**

<b>7</b>								
TRAILER AXLE .....	-	-	759	740	-	370192A	-	45162
	-	-	752	742	-	-	-	-

**NAVISTAR (IHC) Axle Model Index**

Model	Line No.	Model	Line No.	Model	Line No.	Model	Line No.
FA-101	1	FA-51	17	FA-98	33	RA-418	58
FA-102	2	FA-54	17	FA-99	33	RA-42	51
FA-103	3	FA-55	18	RA-180	36	RA-420	59
FA-104	3	FA-57	19	RA-199	37	RA-421	59
FA-109	4	FA58	35	RA-250	39	RA-422	59
FA-118	5	FA-59	19	RA-25/27	38	RA-423	60
FA-119	6	FA-60	20	RA-29	40	RA-438	61
FA-127	7	FA-65	21	RA-294	41	RA-439	61
FA-139	7	FA-68	22	RA-30	42	RA-44	51
FA-140	8	FA-69	23	RA-305	43	RA-441	62
FA-242	9	FA-70	24	RA-307	43	RA-441	62
FA248	34	FA-71	25	RA-341	44	RA-47	52
FA-309	10	FA-72	26	RA-35	45	RA-472	53
FA-329	10	FA-73	27	RA-351	46	RA-474	53
FA-336	11	FA-74	27	RA-355	47	RA-560	62
FA-337	11	FA-75	28	RA-386	48	RA-57	54
FA-338	12	FA-76	28	RA-387	49	RA-570	62
FA-339	13	FA-78	29	RA-39	50	RA-571	62
FA-340	14	FA-80	30	RA-400	55		
FA-342	15	FA-81	31	RA-410	56		
FA-41	16	FA-90	32	RA-411	56		
FA-48	16	FA-91	33	RA-417	57		

Manufacturer Line Number	Inner Set	Outer Set	Inner (Cone/Cup)	Outer (Cone/Cup)	Timken	National	Stemco	SKF

**NAVISTAR (IHC)**

<b>1</b>								
FRONT AXLE .....	-	-	JM207049A	25877	-	370150A	308-0866	28758
	-	-	JM207010	25820	-	-	-	-

<b>2</b>								
FRONT AXLE .....	-	-	39581	3585	TKR847	370001A	308-0836	35066
	-	-	39520	3525	-	-	-	-

<b>3</b>								
FRONT AXLE .....	-	-	JM207049A	25877	-	370150A	308-0866	28758
	-	-	JM207010	25820	-	-	-	-

<b>4</b>								
FRONT AXLE .....	-	-	641	-	-	-	-	-
	-	-	632	-	-	-	-	-
FRONT AXLE .....	-	Set407	-	28682	TKR857	370131A 7	308-0855	45103
	-	-	-	28622	TKR857	-	308-0856	45103
FRONT AXLE .....	-	-	-	3979	TKR855	370124A 8	308-0853	44922
	-	-	-	3920	-	-	-	-

<b>5</b>								
FRONT AXLE .....	Set420	-	H715345	-	-	-	-	-
	-	-	H715311	-	-	-	-	-
FRONT AXLE .....	-	Set407	-	28682	-	370171A 7	-	-
	-	-	-	28622	-	-	-	-
FRONT AXLE .....	-	-	-	3979	TKR855	370124A 8	308-0853	44922
	-	-	-	3920	-	-	-	-

7 Cast Wheels 8 Disc Wheels

HEAVY-DUTY WHEEL BEARING APPLICATIONS

Manufacturer Line Number	Inner Set	Outer Set	Inner (Cone/Cup)	Outer (Cone/Cup)	Timken	National	Stemco	SKF

**NAVISTAR (IHC) (continued)**

<b>6</b>	FRONT AXLE .....	-	-	36990	36990	-	-	-	-
		-	-	36920	36920	-	-	-	-
<b>7</b>	FRONT AXLE .....	Set420	-	H715345	-	-	-	-	-
		-	-	H715311	-	-	-	-	-
	FRONT AXLE .....	-	Set407	-	28682	-	370171A <sup>7</sup>	-	-
		-	-	-	28622	-	-	-	-
	FRONT AXLE .....	-	-	-	3979	TKR855	370124A <sup>8</sup>	308-0853	44922
		-	-	-	3920	-	-	-	-
<b>8</b>	FRONT AXLE .....	-	-	36990	36990	-	-	-	-
		-	-	36920	36920	-	-	-	-
<b>9</b>	FRONT AXLE .....	Set420	Set407	H715345	28682	TKR857	370131A	308-0855	45103
		-	-	H715311	28622	TKR857	-	308-0856	45103
<b>10</b>	FRONT AXLE .....	Set413	Set407	HM212049	28682	TKR855	370124A	308-0853	44922
		-	-	HM212011	28622	-	-	-	-
<b>11</b>	FRONT AXLE .....	Set420	-	H715345	555-S	TKR857	370131A	308-0855	45103
		-	-	H715311	552A	TKR857	-	308-0856	45103
<b>12</b>	FRONT AXLE .....	Set420	Set407	H715345	28682	TKR857	370131A	308-0855	45103
		-	-	H715311	28622	TKR857	-	308-0856	45103
<b>13</b>	FRONT AXLE .....	Set413	Set407	HM212049	28682	TKR855	370124A	308-0853	44922
		-	-	HM212011	28622	-	-	-	-
<b>14</b>	FRONT AXLE .....	Set420	Set407	H715345	28682	TKR857	370131A	308-0855	45103
		-	-	H715311	28622	TKR857	-	308-0856	45103
<b>15</b>	FRONT AXLE .....	Set420	-	H715345	555-S	TKR857	370131A	308-0855	45103
		-	-	H715311	552A	TKR857	-	308-0856	45103
<b>16</b>	FRONT AXLE .....	-	-	26881	-	-	-	-	-
		-	-	26823	-	-	-	-	-
	FRONT AXLE .....	-	-	26884	-	-	-	-	-
		-	-	26823	-	-	-	-	-
	FRONT AXLE .....	-	-	-	1779	-	-	-	-
		-	-	-	1729X	-	-	-	-
<b>17</b>	FRONT AXLE .....	-	-	469	3780	-	-	-	-
		-	-	453X	3720	-	-	-	-
<b>18</b>	FRONT AXLE - W/S164-4X4, SF160-6X6, SF180-6X6 .....	-	-	-	-	-	-	-	-
		-	-	33275	399A	-	-	-	-
		-	-	33472	394A	-	-	-	-
	FRONT AXLE - W/S170/180-4X4 .....	-	-	3578	2689	-	-	-	-
		-	-	3525	2620	-	-	-	-
	FRONT AXLE - EXC S164, SF160, SF180 .....	-	-	47490	395A	-	-	-	-
		-	-	47420	394A	-	-	-	-

<sup>7</sup> Cast Wheels <sup>8</sup> Disc Wheels

Manufacturer Line Number	Inner Set	Outer Set	Inner (Cone/Cup)	Outer (Cone/Cup)	Timken	National	Stemco	SKF

**NAVISTAR (IHC) (continued)**

<b>19</b>	FRONT AXLE .....	-	-	36690	36690	-	-	-	-
		-	-	36620	36620	-	-	-	-
<b>20</b>	FRONT AXLE .....	-	-	3578	2689	-	-	-	-
		-	-	3525	2620	-	-	-	-
<b>21</b>	FRONT AXLE .....	-	-	33895	3196	-	-	-	-
		-	-	33821	3120	-	-	-	-
<b>22</b>	FRONT AXLE .....	-	-	3578	2689	-	-	-	-
		-	-	3525	2620	-	-	-	-
<b>23</b>	FRONT AXLE .....	-	-	3778	2689	-	-	-	-
		-	-	3720	2620	-	-	-	-
<b>24</b>	FRONT AXLE .....	-	-	3578	2689	-	-	-	-
		-	-	3525	2620	-	-	-	-
<b>25</b>	FRONT AXLE .....	-	-	JM205149A	25877	-	370150A	308-0866	28758
		-	-	JM205110	25820	-	-	-	-
<b>26</b>	FRONT AXLE .....	-	-	3578	2689	-	-	-	-
		-	-	3525	2620	-	-	-	-
<b>27</b>	FRONT AXLE .....	-	-	JM205149A	25877	-	370150A	308-0866	28758
		-	-	JM205110	25820	-	-	-	-
<b>28</b>	FRONT AXLE .....	-	-	47490	395A	-	-	-	-
		-	-	47420	394A	-	-	-	-
<b>29</b>	FRONT AXLE .....	-	-	566	33269	-	-	-	-
		-	-	563	33462	-	-	-	-
<b>30</b>	FRONT AXLE .....	-	-	33891	3196	-	370352A	-	27438
		-	-	33821	3120	-	-	-	-
<b>31</b>	FRONT AXLE .....	-	-	566	33269	-	-	-	-
		-	-	563	33462	-	-	-	-
<b>32</b>	FRONT AXLE .....	-	-	539	440	-	-	-	-
		-	-	532A	432	-	-	-	-
<b>33</b>	FRONT AXLE .....	-	-	33895	3196	-	-	-	-
		-	-	33821	3120	-	-	-	-
<b>34</b>	FRONT AXLE .....	-	-	47490	395A	-	-	-	-
		-	-	47420	394A	-	-	-	-

HEAVY-DUTY WHEEL BEARING APPLICATIONS

Manufacturer Line Number	Inner Set	Outer Set	Inner (Cone/Cup)	Outer (Cone/Cup)	Timken	National	Stemco	SKF

**NAVISTAR (IHC) (continued)**

<b>35</b>								
FRONT AXLE .....	-	-	469	3780	-	-	-	-
	-	-	453X	3720	-	-	-	-
<b>36</b>								
REAR AXLE .....	-	-	760	749	-	370004A	-	48884
	-	-	752	742	-	-	-	-
<b>37</b>								
REAR AXLE .....	-	-	47678	39585	TKR849	370023A	309-0912	38780
	-	-	47620	39520	-	-	-	-
<b>38</b>								
REAR AXLE .....	-	-	3984	29585	-	-	-	-
	-	-	3920	29520	-	-	-	-
<b>39</b>								
REAR AXLE .....	-	-	598	575	TKR849	370023A	309-0912	38780
	-	-	592A	572	-	-	-	-
<b>40</b>								
REAR AXLE .....	-	-	33287	39585	-	370169A	-	35000
	-	-	33462	39520	-	-	-	-
<b>41</b>								
REAR AXLE .....	-	-	850	782	-	-	-	-
	-	-	832	772	-	-	-	-
<b>42</b>								
REAR AXLE .....	-	-	33281	39585	-	-	-	-
	-	-	33462	39520	-	-	-	-
<b>43</b>								
REAR AXLE .....	-	-	42688	39585	-	370033A	-	38709
	-	-	42620	39520	-	-	-	-
<b>44</b>								
TANDEM REAR AXLE .....	-	-	42688	39585	-	370033A	-	38709
	-	-	42620	39520	-	-	-	-
TANDEM REAR AXLE - SOME .....	-	-	47678	-	-	-	-	-
	-	-	47620	-	-	-	-	-
<b>45</b>								
REAR AXLE .....	-	-	42688	39585	-	370033A	-	38709
	-	-	42620	39520	-	-	-	-
<b>46</b>								
REAR AXLE .....	Set411	Set408	47686	39590	TKR849	370023A	309-0912	38780
	-	-	47620	39520	-	-	-	-
<b>47</b>								
TANDEM REAR AXLE .....	Set403	Set401	594A	580	TKR858	370021A	309-0964	45160
	-	-	592A	572	-	-	-	-
<b>48</b>								
TANDEM REAR AXLE .....	Set411	Set408	47686	39590	TKR849	370023A	309-0912	38780
	-	-	47620	39520	-	-	-	-
TANDEM REAR AXLE - w/22.5 X14.00 Rims & 6 Spoke Rim (1970 On) .....	-	-	-	-	-	-	-	-
	-	Set413	-	HM212049	-	-	-	-
	-	-	-	HM212011	-	-	-	-
<b>49</b>								
TANDEM REAR AXLE .....	Set403	Set401	594A	580	TKR858	370021A	309-0964	45160
	-	-	592A	572	-	-	-	-

Manufacturer Line Number	Inner Set	Outer Set	Inner (Cone/Cup)	Outer (Cone/Cup)	Timken	National	Stemco	SKF

**NAVISTAR (IHC) (continued)**

<b>50</b>	REAR AXLE .....	-	-	47678	39585	TKR849	370023A	309-0912	38780
		-	-	47620	39520	-	-	-	-
<b>51</b>	REAR AXLE .....	Set411	Set408	47686	39590	TKR849	370023A	309-0912	38780
		-	-	47620	39520	-	-	-	-
<b>52</b>	REAR AXLE .....	Set403	Set401	594A	580	TKR858	370021A	309-0964	45160
		-	-	592A	572	-	-	-	-
<b>53</b>	TANDEM REAR AXLE .....	Set403	Set401	594A	580	TKR858	370021A	309-0964	45160
		-	-	592A	572	-	-	-	-
<b>54</b>	REAR AXLE .....	Set403	Set401	594A	580	TKR861	370003A	309-0973	47697
		-	-	592A	572	-	-	-	-
<b>55</b>	TRAILER AXLE .....	Set403	Set401	594A	580	TKR858	370021A	309-0964	45160
		-	-	592A	572	-	-	-	-
<b>56</b>	TRAILER AXLE .....	Set425	-	567	528	-	370013A	-	35075
		-	-	563	522	-	-	-	-
<b>57</b>	TRAILER AXLE .....	Set405	Set413	663	HM212049	TKR850	370036A	307-0713	40136
		-	-	653	HM212011	-	-	-	-
<b>58</b>	TRAILER AXLE .....	Set403	Set401	594A	580	TKR858	370021A	309-0964	45160
		-	-	592A	572	-	-	-	-
<b>59</b>	TRAILER AXLE .....	Set405	Set413	663	HM212049	TKR850	370036A	307-0713	40136
		-	-	653	HM212011	-	-	-	-
<b>60</b>	TRAILER AXLE .....	Set403	Set401	594A	580	TKR858	370021A	309-0964	45160
		-	-	592A	572	-	-	-	-
<b>61</b>	TRAILER AXLE .....	-	Set406	557A	3782	TKR858	370021A	309-0964	45160
		-	-	553X	3720	-	-	-	-
<b>62</b>	TRAILER AXLE .....	Set405	Set413	663	HM212049	TKR850	370036A	307-0713	40136
		-	-	653	HM212011	-	-	-	-

**INGERSOLL MACHINE & TOOL CO. Axle Model Index**

Model	Line No.	Model	Line No.	Model	Line No.	Model	Line No.
A15S .....	1	A21S .....	3	A26S .....	5	A65S .....	7
A19H/S .....	2	A22H/S .....	4	A45S .....	6		

HEAVY-DUTY WHEEL BEARING APPLICATIONS

Manufacturer Line Number	Inner Set	Outer Set	Inner (Cone/Cup)	Outer (Cone/Cup)	Timken	National	Stemco	SKF

**INGERSOLL MACHINE & TOOL CO.**

<b>1</b>	TRAILER AXLE .....	Set425	-	567 563	528 522	-	-	-	-
<b>2</b>	TRAILER AXLE .....	Set405	Set413	663 653	HM212049 HM212011	-	-	-	-
<b>3</b>	TRAILER AXLE .....	-	-	749 742	643 632	-	-	-	-
<b>4</b>	TRAILER AXLE .....	Set414	Set413	HM218248 HM218210	HM212049 HM212011	-	-	-	-
<b>5</b>	TRAILER AXLE .....	-	-	759 752	740 742	-	-	-	-
<b>6</b>	TRAILER AXLE .....	-	-	787 772	6580 6535	-	-	-	-
<b>7</b>	TRAILER AXLE .....	-	-	896 892	6580 6535	-	-	-	-

**ISUZU Axle Model Index**

Model	Line No.	Model	Line No.	Model	Line No.	Model	Line No.
EVR .....	1	FTR .....	2	FVR .....	3	NPR .....	4

Manufacturer Line Number	Inner Set	Outer Set	Inner (Cone/Cup)	Outer (Cone/Cup)	Timken	National	Stemco	SKF

**ISUZU**

<b>1</b>	.....	-	-	H414245A H414210	-	-	-	-
<b>2</b>	.....	Set412	-	HM212047 HM212011	4388 4335	-	-	-
<b>3</b>	.....	-	-	H414245A H414210	-	-	-	-
<b>4</b>	.....	-	-	29585 29520	28680 28622	-	-	-

**KAY-BRUNNER Axle Model Index**

Model	Line No.	Model	Line No.	Model	Line No.	Model	Line No.
KB4 .....	1	S37 .....	3	T18W .....	10	XHT-21 .....	14
KB5 .....	1	S53 .....	4	T-21 .....	8		
KB6 .....	1	S65 .....	5	T-27 .....	9		
KB7 .....	1	T-100 .....	6	T37 .....	11		
KB8 .....	1	T-11 .....	7	T53 .....	12		
KBW .....	2	T145 .....	10	T65 .....	13		

Manufacturer Line Number	Inner Set	Outer Set	Inner (Cone/Cup)	Outer (Cone/Cup)				
					Timken	National	Stemco	SKF

**KAY-BRUNNER**

<b>1</b>	TRAILER AXLE .....	Set405 -	Set413 -	663 653	HM212049 HM212011	TKR850 -	370036A 1 370349A 2	307-0713 307-0713	40136 40136
<b>2</b>	TRAILER AXLE .....	Set414 -	Set413 -	HM218248 HM218210	HM212049 HM212011	TKR859 -	370025A -	307-0743 -	46305 -
<b>3</b>	TRAILER AXLE .....	- -	- -	861 854	740 742	- -	- -	- -	- -
<b>4</b>	TRAILER AXLE .....	- -	- -	938 932	861 854	- -	- -	- -	- -
<b>5</b>	TRAILER AXLE .....	- -	- -	95525 95925	67390 67320	- -	- -	- -	- -
<b>6</b>	TRAILER AXLE .....	- -	- -	93800 93125	93708 93125	- -	- -	- -	- -
<b>7</b>	TRAILER AXLE .....	- -	- -	560 552A	419 414	- -	- -	- -	- -
<b>8</b>	TRAILER AXLE .....	- -	Set413 -	749 742	HM212049 HM212011	- -	- -	- -	- -
<b>9</b>	TRAILER AXLE .....	- -	- -	759 752	749 742	- -	370057A -	- -	48796 -
<b>10</b>	TRAILER AXLE .....	Set405 -	Set413 -	663 653	HM212049 HM212011	TKR850 -	370036A 1 370349A 2	307-0713 307-0713	40136 40136
<b>11</b>	TRAILER AXLE .....	- -	- -	861 854	740 742	- -	- -	- -	- -
<b>12</b>	TRAILER AXLE .....	- -	- -	938 932	861 854	- -	- -	- -	- -
<b>13</b>	TRAILER AXLE .....	- -	- -	95525 95925	67390 67320	- -	- -	- -	- -
<b>14</b>	TRAILER AXLE .....	- -	Set413 -	749 742	HM212049 HM212011	- -	- -	- -	- -

**KGI LIMITED Axle Model Index**

Model	Line No.	Model	Line No.	Model	Line No.	Model	Line No.
K250 .....	1	KG225 .....	2				

1 Hub Mount 2 Spindle Mount

# HEAVY-DUTY WHEEL BEARING APPLICATIONS

Manufacturer Line Number	Inner Set	Outer Set	Inner (Cone/Cup)	Outer (Cone/Cup)	Timken	National	Stemco	SKF
<b>KGI LIMITED</b>								
<b>1</b>								
TRAILER AXLE .....	-	-	749	643	-	-	-	-
	-	-	742	632	-	-	-	-
<b>2</b>								
TRAILER AXLE .....	Set405	Set413	663	HM212049	-	-	-	-
	-	-	653	HM212011	-	-	-	-

## MACK Axle Model Index

Model	Line No.	Model	Line No.	Model	Line No.	Model	Line No.
EW-48	36	FAN-5351	30	RADP-1205	58	SWD-59	85
EW-573	37	FANL-535	30	RADP-1206	58	SWD-592	85
EW-57	38	FANL-5351	30	RAS-23	59	SWD-5921	85
FA-1000	1	FAS-491	31	RAS-301	60	SWD-593	85
FA-1001	1	FAS-525	32	RAS-307	61	SWD-5951	86
FA-1002	1	FAS-605	33	RAS-507	62	SWD-68	87
FA-1003	1	FAS-6051	33	RAS-508	62	SWD-681	87
FA-301	2	FAW-536	34	RAS-509	62	SWD-682	87
FA-505	3	FAW-537	34	RAS-512	62	SWD-6821	87
FA-507	4	FAW-538	34	RASP-1203	63	SWD-69	88
FA-5071	4	FAW-6044	35	RASP-1300	64	SWD-691	88
FA-511	5	FAW-612	35	RASP-1301	64	SWD-73	89
FA-5111	5	FAW-616	35	RASP-1303	64	SWD-731	90
FA-512	6	FAW-617	35	SA-38	65	SWD-732	90
FA-514	6	FAW-619	35	SC-342	65	SWD-7321	90
FA-5141	7	RA2DT-306	39	SC-38	65	SWD-75	91
FA-517	8	RA2DT-518	40	SH-34	65	SWD-751	92
FA-522	9	RA2DT-519	40	SH-342	66	SWD-76	93
FA-5221	9	RA2DT-521	40	SH-38	67	SWD-761	94
FA-523	9	RA2DT-5211	40	SHB-342	68	SWD-762	94
FA-5231	9	RA2DT-532	41	SHB-38	69	SWD-7621	94
FA-532	10	RAD-111	42	SS-34	70	SWD-83	95
FA-5321	10	RAD-1141	43	SS-342	70	SWD-831	95
FA-534	11	RAD-23	44	SS-38	71	SWD-832	95
FA-5341	11	RAD-231	44	SS-441	72	SWD-833	95
FA-535	12	RAD-29	45	SS-55	73	SWD-84	95
FA-5351	12	RAD-303	46	SS-551	73	SWD-841	95
FA-600	13	RAD-305	46	SS-65	74	SWD-842	95
FA-6001	13	RAD-38	47	SSB-38	75	SWD-843	95
FA-601	13	RAD-507	48	ST-34	75	SWDL-56	96
FA-6011	13	RAD-508	48	SW-342	75	SWDL-563	96
FA-6044	14	RAD-509	48	SW-38	76	SWDL-564	96
FA-612	15	RAD-512	48	SW-441	76	SWDL-73	97
FA-700	16	RAD-529	48	SW-55	77	SWDL-731	98
FA-701	16	RAD-5291	48	SW-551	78	SWDL-732	98
FA-702	16	RAD-530	48	SW-65	79	SWDL-7321	98
FA-703	17	RAD-533	49	SW-80	80	SWDL-75	99
FA-704	18	RAD-606	50	SWA-57	81	SWDL-751	100
FA-800	19	RAD-608	50	SWB-342	81	SWDL-76	101
FA-801	19	RAD-703	50	SWB-38	81	SWDL-761	102
FA-900	20	RAD-704	50	SWC-562	81	SWDL-762	102
FA-901	20	RAD-705	50	SWC-57	81	SWDL-7621	102
FAD-605	21	RAD-706	50	SWD-56	81	SWDL-78	103
FAFW-537	22	RAD-707	50	SWD-561	82	SWDL-781	104
FAL-5051	23	RAD-708	50	SWD-57	83	SWDL-782	104
FAL-5071	24	RADF-1000	51	SWD-5701	83	SWDL-783	104
FAL-522	25	RADL-515	52	SWD-571	83	SWDP-43	105
FAL-5221	25	RADL-5153	52	SWD-5711	83	SWDR-48	106
FAL-523	25	RADL-528	53	SWD-572	83	SWH-56	107
FAL-5231	25	RADL-5281	53	SWD-573	83	SWH-562	107
FAL-532	26	RADL-529	54	SWD-5731	83	SWH-57	107
FAL5321	28	RADL-5291	54	SWD-574	83	SWH-573	108
FAL-535	27	RADL-533	55	SWD-5741	83	SWH-76	109
FAN-534	29	RADP-1000	56	SWD-575	83	SWH-762	110
FAN-5341	29	RADP-1001	56	SWD-5751	83	SWP-800	111
FAN-535	30	RADP-1201	57	SWD-58	84	SWP-801	111

**MACK Axle Model Index (continued)**

Model	Line No.	Model	Line No.	Model	Line No.	Model	Line No.
SWS-56	112	SWS-68	113	SWSP-642	118	SWW-68	121
SWS-562	112	SWS-681	113	SWSP-72	119	SWW-681	121
SWS-57	112	SWS-76	114	SWTL-56	120	SWW-69	122
SWS-570	112	SWS-92	115	SWW-562	120	SWW-76	123
SWS5711	116	SWS-93	115	SWW-57	120	SWW-762	124
SWS573	116	SWS-94	115	SWW-571	120	SWWL-56	124
SWS5731	116	SWSL-56	117	SWW-573	120	SWWL-562	124
SWS-59	113	SWSP-64	118	SWW-59	121	SWWP-90	125
SWS-592	113	SWSP-641	118	SWW-592	121	SWWP-95	125

Manufacturer Line Number	Inner Set	Outer Set	Inner (Cone/Cup)	Outer (Cone/Cup)	Timken	National	Stemco	SKF

**MACK**

<b>1</b>	FRONT AXLE	-	-	EE107057 107105	6580 6535	-	-	-	-
<b>2</b>	FRONT AXLE	-	-	49580 49521	2790 2720	-	-	-	-
<b>3</b>	FRONT AXLE	-	-	4595 4536	418 414A	-	370014A	-	31281
<b>4</b>	FRONT AXLE	-	-	559 552A	526 522	-	370011A	-	36358
<b>5</b>	FRONT AXLE	-	-	4595 4536	418 414A	-	370014A	-	31281
<b>6</b>	FRONT AXLE	-	-	559 552A	526 522	-	370011A	-	36358
<b>7</b>	FRONT AXLE - w/Std Whls to 1968 & All 1968-69 w/Alum Whls	-	-	- 559 552A	- 526 522	-	- 370011A	-	- 36358
	FRONT AXLE - w/Std Whls After 1968 RC	-	-	3982 3920	3877 3820	-	370011A	-	36358
<b>8</b>	FRONT AXLE	-	-	559 552A	526 522	-	370011A	-	36358
<b>9</b>	FRONT AXLE	-	-	641 633	65385 65320	-	370198A	-	-
<b>10</b>	FRONT AXLE - w/Std Whls to 1968 & All 1968-69 w/Alum Whls	-	-	- 641 633	- 65385 65320	-	- 370198A	-	-
	FRONT AXLE - w/Std Whls After 1968 RC	Set413	Set409	HM212049 HM212011	45280 45220	-	370033A	-	38709
<b>11</b>	FRONT AXLE - w/Std Whls to 1968 & All 1968-69 w/Alum Whls	-	-	- 4595 4536	- 418 414A	-	- 370014A	-	- 31281
	FRONT AXLE - w/Std Whls After 1968 RC	-	-	39578 39520	25572 25520	-	370014A	-	31281

HEAVY-DUTY WHEEL BEARING APPLICATIONS

Manufacturer Line Number	Inner Set	Outer Set	Inner (Cone/Cup)	Outer (Cone/Cup)	Timken	National	Stemco	SKF

**MACK** (continued)

<b>12</b>								
FRONT AXLE - w/Std Whls to 1968 & All 1968-69 w/Alum Whls .....	-	-	-	-	-	-	-	-
	-	-	559	526	-	370011A	-	36358
	-	-	552A	522	-	-	-	-
FRONT AXLE - w/Std Whls After 1968 RC .....	-	-	3982	3877	-	370011A	-	36358
	-	-	3920	3820	-	-	-	-
<b>13</b>								
FRONT AXLE - w/Std Whls to 1968 & All 1968-69 w/Alum Whls .....	-	-	-	-	-	-	-	-
	-	-	6461	621	-	370198A	-	-
	-	-	6420	612	-	-	-	-
FRONT AXLE - w/Std Whls After 1968 RC .....	-	-	5760	45287	-	-	-	-
	-	-	5735	45220	-	-	-	-
<b>14</b>								
FRONT AXLE .....	Set423	-	6461A	555-S	-	370182A	-	43764
	-	-	6420	552A	-	-	-	-
<b>15</b>								
FRONT AXLE .....	Set423	-	6461A	555-S	-	370020A	309-0964	-
	-	-	6420	552A	-	-	-	-
<b>16</b>								
FRONT AXLE .....	-	-	665	4595	-	370020A	309-0964	-
	-	-	653	4535	-	-	-	-
<b>17</b>								
FRONT AXLE .....	-	-	758	4595	-	-	-	-
	-	-	752A	4535	-	-	-	-
<b>18</b>								
FRONT AXLE .....	-	-	665	4595	-	370020A	309-0964	-
	-	-	653	4535	-	-	-	-
<b>19</b>								
FRONT AXLE .....	-	-	HH221449	664	-	-	-	-
	-	-	HH221410	652	-	-	-	-
<b>20</b>								
FRONT AXLE .....	-	-	941	749	-	-	-	-
	-	-	932	742	-	-	-	-
<b>21</b>								
FRONT DRIVE AXLE .....	-	-	71450	52400	-	-	-	-
	-	-	71750	52637	-	-	-	-
<b>22</b>								
FRONT AXLE .....	Set413	Set409	HM212049	45280	-	370033A	-	38709
	-	-	HM212011	45220	-	-	-	-
<b>23</b>								
FRONT AXLE .....	-	-	4595	418	-	370014A	-	31281
	-	-	4536	414A	-	-	-	-
<b>24</b>								
FRONT AXLE .....	-	-	559	526	-	370011A	-	36358
	-	-	552A	522	-	-	-	-
<b>25</b>								
FRONT AXLE .....	-	-	641	65385	-	370198A	-	-
	-	-	633	65320	-	-	-	-
<b>26</b>								
FRONT AXLE - w/Std Whls to 1968 & All 1968-69 w/Alum Whls .....	-	-	-	-	-	-	-	-
	-	-	641	65385	-	370198A	-	-
	-	-	633	65320	-	-	-	-

Manufacturer Line Number	Inner Set	Outer Set	Inner (Cone/Cup)	Outer (Cone/Cup)	Timken	National	Stemco	SKF

**MACK (continued)**

FRONT AXLE - w/Std Whls After 1968 RC .....	Set413	Set409	HM212049 HM212011	45280 45220	- -	370033A -	- -	38709 -
<b>27</b>								
FRONT AXLE - w/Std Whls to 1968 & All 1968-69 w/Alum Whls .....	- -	- -	- 559 552A	- 526 522	- - -	- 370011A -	- - -	- 36358 -
FRONT AXLE - w/Std Whls After 1968 RC .....	- -	- -	3982 3920	3877 3820	- -	370011A -	- -	36358 -
<b>28</b>								
FRONT AXLE - w/Std Whls to 1968 & All 1968-69 w/Alum Whls .....	- -	- -	- 641 633	- 65385 65320	- - -	- 370198A -	- - -	- - -
FRONT AXLE - w/Std Whls After 1968 RC .....	Set413	Set409	HM212049 HM212011	45280 45220	- -	370033A -	- -	38709 -
<b>29</b>								
FRONT AXLE .....	- -	- -	4595 4536	418 414A	- -	370014A -	- -	31281 -
<b>30</b>								
FRONT AXLE .....	- -	- -	559 552A	526 522	- -	370011A -	- -	36358 -
<b>31</b>								
FRONT DRIVE AXLE .....	- -	- -	5760 5735	528A 522	- -	- -	- -	- -
<b>32</b>								
FRONT DRIVE AXLE .....	- -	- -	36990 36920	36990 36920	- -	- -	- -	- -
<b>33</b>								
FRONT DRIVE AXLE .....	- -	- -	71450 71750	52400 52637	- -	- -	- -	- -
<b>34</b>								
FRONT AXLE .....	Set413	Set409	HM212049 HM212011	45280 45220	- -	370033A -	- -	38709 -
<b>35</b>								
FRONT AXLE .....	Set423	-	6461A 6420	555-S 552A	- -	370182A -	- -	43764 -
<b>36</b>								
TANDEM REAR AXLE .....	Set402	Set425	582 572	567 563	TKR856 -	370022A -	309-0903 -	45099 -
<b>37</b>								
TANDEM REAR AXLE - TO 1968 RC & W/ALUM HUB 1970 ON .....	- -	- -	- 663 652	- 575 572	- - -	- - -	- - -	- - -
TANDEM REAR AXLE - 1968 RC ON .....	- -	Set426	HM516449 HM516410	47679 47620	- -	- -	- -	- -
<b>38</b>								
TANDEM REAR AXLE .....	Set402	Set425	582 572	567 563	- -	- -	- -	- -
<b>39</b>								
REAR AXLE .....	Set402	-	582 572	42687 42620	- -	370030A -	309-0961 -	42800 -
<b>40</b>								
REAR AXLE .....	Set404	Set401	598A 592A	580 572	TKR861 -	370003A -	309-0973 -	47697 -

HEAVY-DUTY WHEEL BEARING APPLICATIONS

Manufacturer Line Number	Inner Set	Outer Set	Inner (Cone/Cup)	Outer (Cone/Cup)	Timken	National	Stemco	SKF

**MACK** (continued)

<b>41</b>								
REAR AXLE .....	-	Set401	598	580	TKR861	370003A	309-0973	47697
	-	-	592A	572	-	-	-	-
<b>42</b>								
REAR AXLE .....	-	-	780	864	-	-	-	-
	-	-	772	854	-	-	-	-
<b>43</b>								
REAR AXLE .....	-	-	780	-	-	370028A	-	50124
	-	-	772	-	-	-	-	-
REAR AXLE - SPOKE .....	-	-	-	776	-	370028A	-	50124
	-	-	-	772	-	-	-	-
REAR AXLE - DISC .....	-	-	-	77375	-	370028A	-	50124
	-	-	-	77675	-	-	-	-
<b>44</b>								
REAR AXLE .....	-	-	598	-	-	-	-	-
	-	-	592A	-	-	-	-	-
REAR AXLE - TO 1968 RC .....	-	-	-	758	-	-	-	-
	-	-	-	752	-	-	-	-
REAR AXLE - 1968 RC ON .....	-	-	-	HM617049	-	-	-	-
	-	-	-	HM617010	-	-	-	-
REAR AXLE - ALUM WHLS .....	-	-	-	665	-	-	-	-
	-	-	-	653	-	-	-	-
<b>45</b>								
REAR AXLE .....	-	-	780	-	-	370028A	-	50124
	-	-	772	-	-	-	-	-
REAR AXLE - SPOKE .....	-	-	-	776	-	370028A	-	50124
	-	-	-	772	-	-	-	-
REAR AXLE - DISC .....	-	-	-	77375	-	370028A	-	50124
	-	-	-	77675	-	-	-	-
<b>46</b>								
REAR AXLE .....	Set401	Set425	580	567	TKR850	370036A	307-0713	40136
	-	-	572	563	-	-	-	-
<b>47</b>								
REAR AXLE .....	-	-	780	-	-	370028A	-	50124
	-	-	772	-	-	-	-	-
REAR AXLE - SPOKE .....	-	-	-	776	-	370028A	-	50124
	-	-	-	772	-	-	-	-
REAR AXLE - DISC .....	-	-	-	77375	-	370028A	-	50124
	-	-	-	77675	-	-	-	-
<b>48</b>								
REAR AXLE .....	-	-	598	-	-	-	-	-
	-	-	592A	-	-	-	-	-
REAR AXLE - TO 1968 RC .....	-	-	-	758	-	-	-	-
	-	-	-	752	-	-	-	-
REAR AXLE - 1968 RC ON .....	-	-	-	HM617049	-	-	-	-
	-	-	-	HM617010	-	-	-	-
REAR AXLE - ALUM WHLS .....	-	-	-	665	-	-	-	-
	-	-	-	653	-	-	-	-
<b>49</b>								
REAR AXLE .....	-	-	598	-	TKR854	370019A	309-0965	43860
	-	-	592A	-	-	-	-	-
REAR AXLE - TO 1968 RC .....	-	-	-	758	TKR854	370019A	309-0965	43860
	-	-	-	752	-	-	-	-

Manufacturer Line Number	Inner Set	Outer Set	Inner (Cone/Cup)	Outer (Cone/Cup)	Timken	National	Stemco	SKF

**MACK (continued)**

REAR AXLE - 1968 RC ON .....	-	-	-	HM617049	TKR854	370019A	309-0965	43860
	-	-	-	HM617010	-	-	-	-
REAR AXLE - ALUM WHLS .....	-	-	-	665	TKR854	370019A	309-0965	43860
	-	-	-	653	-	-	-	-

**50**

REAR AXLE .....	-	-	780	-	-	370028A	-	50124
	-	-	772	-	-	-	-	-
REAR AXLE - SPOKE .....	-	-	-	776	-	370028A	-	50124
	-	-	-	772	-	-	-	-
REAR AXLE - DISC .....	-	-	-	77375	-	370028A	-	50124
	-	-	-	77675	-	-	-	-

**51**

REAR AXLE .....	-	-	67390	938	-	-	-	-
	-	-	67322	932	-	-	-	-

**52**

REAR AXLE .....	-	-	598	758	TKR854	370019A	309-0965	43860
	-	-	592A	752	-	-	-	-
REAR AXLE - ALUM WHLS .....	-	-	-	665	TKR854	370019A	309-0965	43860
	-	-	-	653	-	-	-	-

**53**

REAR AXLE .....	-	-	598	-	TKR854	370019A	309-0965	43860
	-	-	592A	-	-	-	-	-
REAR AXLE - TO 1968 RC .....	-	-	-	758	-	-	-	-
	-	-	-	752	-	-	-	-
REAR AXLE - 1968 RC ON .....	-	-	-	HM617049	-	-	-	-
	-	-	-	HM617010	-	-	-	-
REAR AXLE - ALUM WHLS .....	-	-	-	665	-	-	-	-
	-	-	-	653	-	-	-	-

**54**

REAR AXLE .....	-	-	598	-	-	-	-	-
	-	-	592A	-	-	-	-	-
REAR AXLE - TO 1968 RC .....	-	-	-	758	-	-	-	-
	-	-	-	752	-	-	-	-
REAR AXLE - 1968 RC ON .....	-	-	-	HM617049	-	-	-	-
	-	-	-	HM617010	-	-	-	-
REAR AXLE - ALUM WHLS .....	-	-	-	665	-	-	-	-
	-	-	-	653	-	-	-	-

**55**

REAR AXLE .....	-	-	598	-	TKR854	370019A	309-0965	43860
	-	-	592A	-	-	-	-	-
REAR AXLE - TO 1968 RC .....	-	-	-	758	TKR854	370019A	309-0965	43860
	-	-	-	752	-	-	-	-
REAR AXLE - 1968 RC ON .....	-	-	-	HM617049	TKR854	370019A	309-0965	43860
	-	-	-	HM617010	-	-	-	-
REAR AXLE - ALUM WHLS .....	-	-	-	665	TKR854	370019A	309-0965	43860
	-	-	-	653	-	-	-	-

**56**

REAR AXLE .....	-	-	67390	938	-	-	-	-
	-	-	67322	932	-	-	-	-

**57**

REAR AXLE .....	-	-	99575	HH228349	-	-	-	-
	-	-	99100	HH228310	-	-	-	-

**58**

REAR AXLE .....	-	-	M236845	HH228349	-	-	-	-
	-	-	M236810	HH228310	-	-	-	-

HEAVY-DUTY WHEEL BEARING APPLICATIONS

Manufacturer Line Number	Inner Set	Outer Set	Inner (Cone/Cup)	Outer (Cone/Cup)	Timken	National	Stemco	SKF

**MACK** (continued)

<b>59</b>								
REAR AXLE .....	-	-	598	-	TKR854	370019A	309-0965	43860
	-	-	592A	-	-	-	-	-
REAR AXLE - TO 1968 RC .....	-	-	-	758	TKR854	370019A	309-0965	43860
	-	-	-	752	-	-	-	-
REAR AXLE - 1968 RC ON .....	-	-	-	HM617049	TKR854	370019A	309-0965	43860
	-	-	-	HM617010	-	-	-	-
REAR AXLE - ALUM WHLS .....	-	-	-	665	TKR854	370019A	309-0965	43860
	-	-	-	653	-	-	-	-
<b>60</b>								
REAR AXLE .....	Set401	Set425	580	567	TKR850	370036A	307-0713	40136
	-	-	572	563	-	-	-	-
<b>61</b>								
REAR AXLE .....	Set402	-	582	42687	-	370030A	309-0961	42800
	-	-	572	42620	-	-	-	-
<b>62</b>								
REAR AXLE .....	-	-	598	-	TKR854	370019A	309-0965	43860
	-	-	592A	-	-	-	-	-
REAR AXLE - TO 1968 RC .....	-	-	-	758	TKR854	370019A	309-0965	43860
	-	-	-	752	-	-	-	-
REAR AXLE - 1968 RC ON .....	-	-	-	HM617049	TKR854	370019A	309-0965	43860
	-	-	-	HM617010	-	-	-	-
REAR AXLE - ALUM WHLS .....	-	-	-	665	TKR854	370019A	309-0965	43860
	-	-	-	653	-	-	-	-
<b>63</b>								
REAR AXLE .....	-	-	M236845	HH228349	-	-	-	-
	-	-	M236810	HH228310	-	-	-	-
<b>64</b>								
REAR AXLE .....	-	-	8573	H247535	-	-	-	-
	-	-	8520	H247510	-	-	-	-
<b>65</b>								
TANDEM REAR AXLE .....	Set402	Set425	582	567	-	-	-	-
	-	-	572	563	-	-	-	-
<b>66</b>								
TANDEM REAR AXLE .....	Set402	Set425	582	567	TKR856	370022A	309-0903	45099
	-	-	572	563	-	-	-	-
<b>67</b>								
TANDEM REAR AXLE .....	Set402	Set425	582	567	-	-	-	-
	-	-	572	563	-	-	-	-
<b>68</b>								
TANDEM REAR AXLE .....	Set402	Set425	582	567	TKR856	370022A	309-0903	45099
	-	-	572	563	-	-	-	-
<b>69</b>								
TANDEM REAR AXLE .....	Set402	Set425	582	567	-	-	-	-
	-	-	572	563	-	-	-	-
<b>70</b>								
TANDEM REAR AXLE .....	Set402	Set425	582	567	TKR856	370022A	309-0903	45099
	-	-	572	563	-	-	-	-
<b>71</b>								
TANDEM REAR AXLE .....	Set402	Set425	582	567	-	-	-	-
	-	-	572	563	-	-	-	-

Manufacturer Line Number	Inner Set	Outer Set	Inner (Cone/Cup)	Outer (Cone/Cup)	Timken	National	Stemco	SKF

**MACK (continued)**

<b>72</b>								
TANDEM REAR AXLE - TO 1968 RC & W/ALUM HUB 1970 ON .....	-	-	-	-	-	-	-	-
	-	-	663	575	-	-	-	-
	-	-	652	572	-	-	-	-
TANDEM REAR AXLE - 1968 RC ON .....	-	Set426	HM516449	47679	-	-	-	-
	-	-	HM516410	47620	-	-	-	-

<b>73</b>								
TANDEM REAR AXLE - TO 1968 RC & W/ALUM HUB 1970 ON .....	-	-	-	-	-	-	-	-
	-	-	780	687	-	-	-	-
	-	-	772	672	-	-	-	-
TANDEM REAR AXLE - 1968 RC ON .....	-	-	687	52400	-	-	-	-
	-	-	672	52618	-	-	-	-
TANDEM REAR AXLE - W/ 1200 X 24 TIRES ..	-	-	687	780	-	-	-	-
	-	-	672	772	-	-	-	-

<b>74</b>								
TANDEM REAR AXLE - w/ 1100 X 24 Tires .....	-	-	780	-	-	-	-	-
	-	-	772	-	-	-	-	-
TANDEM REAR AXLE - SPOKE w/1100 X 24 Tires .....	-	-	-	-	-	-	-	-
	-	-	-	776	-	-	-	-
	-	-	-	772	-	-	-	-
TANDEM REAR AXLE - DISC w/ 1100 X 24 Tires .....	-	-	-	-	-	-	-	-
	-	-	-	77375	-	-	-	-
	-	-	-	77675	-	-	-	-
TANDEM REAR AXLE - w/ 1200 X 24 Tires .....	-	-	780	864	-	370069A	309-0948	52658
	-	-	772	854	-	-	-	-

<b>75</b>								
TANDEM REAR AXLE .....	Set402	Set425	582	567	TKR856	370022A	309-0903	45099
	-	-	572	563	-	-	-	-

<b>76</b>								
TANDEM REAR AXLE .....	Set402	Set425	582	567	-	-	-	-
	-	-	572	563	-	-	-	-

<b>77</b>								
TANDEM REAR AXLE - TO 1968 RC & W/ALUM HUB 1970 ON .....	-	-	-	-	-	-	-	-
	-	-	780	687	-	-	-	-
	-	-	772	672	-	-	-	-
TANDEM REAR AXLE - 1968 RC ON .....	-	-	687	52400	-	-	-	-
	-	-	672	52618	-	-	-	-
TANDEM REAR AXLE - W/ 1200 X 24 TIRES ..	-	-	687	780	-	370069A	309-0948	52658
	-	-	672	772	-	-	-	-

<b>78</b>								
TANDEM REAR AXLE - TO 1968 RC & W/ALUM HUB 1970 ON .....	-	-	-	-	-	-	-	-
	-	-	780	687	-	-	-	-
	-	-	772	672	-	-	-	-
TANDEM REAR AXLE - 1968 RC ON .....	-	-	687	52400	-	-	-	-
	-	-	672	52618	-	-	-	-
TANDEM REAR AXLE - W/ 1200 X 24 TIRES ..	-	-	687	780	-	-	-	-
	-	-	672	772	-	-	-	-

<b>79</b>								
TANDEM REAR AXLE - TO 1968 RC & W/ALUM HUB 1970 ON .....	-	-	-	-	-	-	-	-
	-	-	780	687	-	-	-	-
	-	-	772	672	-	-	-	-
TANDEM REAR AXLE - 1968 RC ON .....	-	-	687	52400	-	-	-	-
	-	-	672	52618	-	-	-	-
TANDEM REAR AXLE - W/ 1200 X 24 TIRES ..	-	-	687	780	-	370069A	309-0948	52658
	-	-	672	772	-	-	-	-

HEAVY-DUTY WHEEL BEARING APPLICATIONS

Manufacturer Line Number	Inner Set	Outer Set	Inner (Cone/Cup)	Outer (Cone/Cup)	Timken	National	Stemco	SKF

**MACK** (continued)

<b>80</b>								
TANDEM REAR AXLE .....	-	-	71425	861	-	-	-	-
	-	-	71750	854	-	-	-	-
<b>81</b>								
TANDEM REAR AXLE .....	Set402	Set425	582	567	-	-	-	-
	-	-	572	563	-	-	-	-
<b>82</b>								
TANDEM REAR AXLE .....	Set402	Set425	582	567	TKR856	370022A	309-0903	45099
	-	-	572	563	-	-	-	-
<b>83</b>								
TANDEM REAR AXLE - TO 1968 RC & WALUM HUB 1970 ON .....	-	-	-	-	-	-	-	-
	-	-	663	575	-	-	-	-
	-	-	652	572	-	-	-	-
TANDEM REAR AXLE - 1968 RC ON .....	-	Set426	HM516449	47679	-	-	-	-
	-	-	HM516410	47620	-	-	-	-
<b>84</b>								
TANDEM REAR AXLE .....	-	-	759	664	-	-	-	-
	-	-	752	652	-	-	-	-
<b>85</b>								
TANDEM REAR AXLE - w/ 1100 X 24 Tires .....	-	-	780	-	-	-	-	-
	-	-	772	-	-	-	-	-
TANDEM REAR AXLE - SPOKE w/1100 X 24 Tires .....	-	-	-	776	-	-	-	-
	-	-	-	772	-	-	-	-
TANDEM REAR AXLE - DISC w/ 1100 X 24 Tires .....	-	-	-	-	-	-	-	-
	-	-	-	77375	-	-	-	-
	-	-	-	77675	-	-	-	-
TANDEM REAR AXLE - w/ 1200 X 24 Tires .....	-	-	780	864	-	370069A	309-0948	52658
	-	-	772	854	-	-	-	-
<b>86</b>								
TANDEM REAR AXLE - TO 1968 RC & WALUM HUB 1970 ON .....	-	-	-	-	-	-	-	-
	-	-	780	687	-	-	-	-
	-	-	772	672	-	-	-	-
TANDEM REAR AXLE - 1968 RC ON .....	-	-	687	52400	-	-	-	-
	-	-	672	52618	-	-	-	-
TANDEM REAR AXLE - W/ 1200 X 24 TIRES ..	-	-	687	780	-	370069A	309-0948	52658
	-	-	672	772	-	-	-	-
<b>87</b>								
TANDEM REAR AXLE - w/ 1100 X 24 Tires .....	-	-	780	-	-	-	-	-
	-	-	772	-	-	-	-	-
TANDEM REAR AXLE - SPOKE w/1100 X 24 Tires .....	-	-	-	776	-	-	-	-
	-	-	-	772	-	-	-	-
TANDEM REAR AXLE - DISC w/ 1100 X 24 Tires .....	-	-	-	-	-	-	-	-
	-	-	-	77375	-	-	-	-
	-	-	-	77675	-	-	-	-
TANDEM REAR AXLE - w/ 1200 X 24 Tires .....	-	-	780	864	-	370069A	309-0948	52658
	-	-	772	854	-	-	-	-
<b>88</b>								
TANDEM REAR AXLE .....	-	-	71425	861	-	-	-	-
	-	-	71750	854	-	-	-	-
<b>89</b>								
TANDEM REAR AXLE .....	Set402	Set425	582	567	TKR856	370022A	309-0903	45099
	-	-	572	563	-	-	-	-

Manufacturer Line Number	Inner Set	Outer Set	Inner (Cone/Cup)	Outer (Cone/Cup)	Timken	National	Stemco	SKF

**MACK (continued)**

<b>90</b>	TANDEM REAR AXLE .....	Set402 -	Set425 -	582 572	567 563	- -	- -	- -	- -
<b>91</b>	TANDEM REAR AXLE .....	Set402 -	Set425 -	582 572	567 563	TKR856 -	370022A -	309-0903 -	45099 -
<b>92</b>	TANDEM REAR AXLE .....	Set402 -	Set425 -	582 572	567 563	- -	- -	- -	- -
<b>93</b>	TANDEM REAR AXLE .....	Set402 -	Set425 -	582 572	567 563	TKR856 -	370022A -	309-0903 -	45099 -
<b>94</b>	TANDEM REAR AXLE .....	Set402 -	Set425 -	582 572	567 563	- -	- -	- -	- -
<b>95</b>	TANDEM REAR AXLE .....	Set401 -	- -	580 572	5752 5735	TKR856 -	370022A -	309-0903 -	45099 -
	TANDEM REAR AXLE - DUAL .....	- -	Set425 -	- -	567 563	TKR856 -	370022A -	309-0903 -	45099 -
<b>96</b>	TANDEM REAR AXLE .....	Set402 -	Set425 -	582 572	567 563	- -	- -	- -	- -
<b>97</b>	TANDEM REAR AXLE .....	Set402 -	Set425 -	582 572	567 563	TKR856 -	370022A -	309-0903 -	45099 -
<b>98</b>	TANDEM REAR AXLE .....	Set402 -	Set425 -	582 572	567 563	- -	- -	- -	- -
<b>99</b>	TANDEM REAR AXLE .....	Set402 -	Set425 -	582 572	567 563	TKR856 -	370022A -	309-0903 -	45099 -
<b>100</b>	TANDEM REAR AXLE .....	Set402 -	Set425 -	582 572	567 563	- -	- -	- -	- -
<b>101</b>	TANDEM REAR AXLE .....	Set402 -	Set425 -	582 572	567 563	TKR856 -	370022A -	309-0903 -	45099 -
<b>102</b>	TANDEM REAR AXLE .....	Set402 -	Set425 -	582 572	567 563	- -	- -	- -	- -
<b>103</b>	TANDEM REAR AXLE .....	Set402 -	Set425 -	582 572	567 563	TKR856 -	370022A -	309-0903 -	45099 -
<b>104</b>	TANDEM REAR AXLE .....	Set402 -	Set425 -	582 572	567 563	- -	- -	- -	- -
<b>105</b>	TANDEM REAR AXLE .....	- -	- -	74500 74850	938 932	- -	- -	- -	- -

HEAVY-DUTY WHEEL BEARING APPLICATIONS

Manufacturer Line Number	Inner Set	Outer Set	Inner (Cone/Cup)	Outer (Cone/Cup)	Timken	National	Stemco	SKF

**MACK** (continued)

<b>106</b>								
TANDEM REAR AXLE .....	-	-	598	758	-	-	-	-
	-	-	592A	752	-	-	-	-
TANDEM REAR AXLE - ALUM .....	-	-	-	665	-	-	-	-
	-	-	-	653	-	-	-	-
<b>107</b>								
TANDEM REAR AXLE .....	Set402	Set425	582	567	-	-	-	-
	-	-	572	563	-	-	-	-
<b>108</b>								
TANDEM REAR AXLE - TO 1968 RC & W/ALUM HUB 1970 ON .....	-	-	-	-	-	-	-	-
	-	-	663	575	-	-	-	-
	-	-	652	572	-	-	-	-
TANDEM REAR AXLE - 1968 RC ON .....	-	Set426	HM516449	47679	-	-	-	-
	-	-	HM516410	47620	-	-	-	-
<b>109</b>								
TANDEM REAR AXLE .....	Set402	Set425	582	567	TKR856	370022A	309-0903	45099
	-	-	572	563	-	-	-	-
<b>110</b>								
TANDEM REAR AXLE .....	Set402	Set425	582	567	-	-	-	-
	-	-	572	563	-	-	-	-
<b>111</b>								
TANDEM REAR AXLE .....	-	-	67390	938	-	-	-	-
	-	-	67322	932	-	-	-	-
<b>112</b>								
TANDEM REAR AXLE .....	Set402	Set425	582	567	-	-	-	-
	-	-	572	563	-	-	-	-
<b>113</b>								
TANDEM REAR AXLE - TO 1968 RC & W/ALUM HUB 1970 ON .....	-	-	-	-	-	-	-	-
	-	-	780	687	-	-	-	-
	-	-	772	672	-	-	-	-
TANDEM REAR AXLE - 1968 RC ON .....	-	-	687	52400	-	-	-	-
	-	-	672	52618	-	-	-	-
TANDEM REAR AXLE - W/ 1200 X 24 TIRES ..	-	-	687	780	-	370069A	309-0948	52658
	-	-	672	772	-	-	-	-
<b>114</b>								
TANDEM REAR AXLE .....	Set402	Set425	582	567	-	-	-	-
	-	-	572	563	-	-	-	-
<b>115</b>								
TANDEM REAR AXLE - TO 1968 RC & W/ALUM HUB 1970 ON .....	-	-	-	-	-	-	-	-
	-	-	780	687	-	-	-	-
	-	-	772	672	-	-	-	-
TANDEM REAR AXLE - 1968 RC ON .....	-	-	687	52400	-	-	-	-
	-	-	672	52618	-	-	-	-
TANDEM REAR AXLE - W/ 1200 X 24 TIRES ..	-	-	687	780	-	370069A	309-0948	52658
	-	-	672	772	-	-	-	-
<b>116</b>								
TANDEM REAR AXLE - TO 1968 RC & W/ALUM HUB 1970 ON .....	-	-	-	-	-	-	-	-
	-	-	663	575	-	-	-	-
	-	-	652	572	-	-	-	-
TANDEM REAR AXLE - 1968 RC ON .....	-	Set426	HM516449	47679	-	-	-	-
	-	-	HM516410	47620	-	-	-	-
<b>117</b>								
TANDEM REAR AXLE .....	Set402	Set425	582	567	-	-	-	-
	-	-	572	563	-	-	-	-

Manufacturer Line Number	Inner Set	Outer Set	Inner (Cone/Cup)	Outer (Cone/Cup)				
					Timken	National	Stemco	SKF

**MACK (continued)**

<b>118</b>	TANDEM REAR AXLE .....	-	-	M236845	HH228349	-	-	-	-
		-	-	M236810	HH228310	-	-	-	-
<b>119</b>	TANDEM REAR AXLE .....	-	-	8573	EE420801	-	-	-	-
		-	-	8520	421437	-	-	-	-
<b>120</b>	TANDEM REAR AXLE .....	Set402	Set425	582	567	-	-	-	-
		-	-	572	563	-	-	-	-
<b>121</b>	TANDEM REAR AXLE - TO 1968 RC & W/ALUM HUB 1970 ON .....	-	-	-	-	-	-	-	-
		-	-	780	687	-	-	-	-
		-	-	772	672	-	-	-	-
	TANDEM REAR AXLE - 1968 RC ON .....	-	-	687	52400	-	-	-	-
		-	-	672	52618	-	-	-	-
	TANDEM REAR AXLE - W/ 1200 X 24 TIRES ..	-	-	687	780	-	370069A	309-0948	52658
		-	-	672	772	-	-	-	-
<b>122</b>	TANDEM REAR AXLE .....	-	-	71425	861	-	-	-	-
		-	-	71750	854	-	-	-	-
<b>123</b>	TANDEM REAR AXLE .....	Set402	Set425	582	567	TKR856	370022A	309-0903	45099
		-	-	572	563	-	-	-	-
<b>124</b>	TANDEM REAR AXLE .....	Set402	Set425	582	567	-	-	-	-
		-	-	572	563	-	-	-	-
<b>125</b>	TANDEM REAR AXLE .....	-	-	67390	938	-	-	-	-
		-	-	67322	932	-	-	-	-

**MACK MID-LINER Axle Model Index**

Model	Line No.	Model	Line No.	Model	Line No.	Model	Line No.
408.00 .....	1	MS250 .....	3	P1021.5 .....	3	P1121G2 .....	3
408.01 .....	1	MS300 .....	3	P1021G1 .....	3	P802.2 .....	3
408.03 .....	1	P102011 .....	3	P112102 .....	3	P820G .....	3
408.04 .....	1	P1020B .....	3	P1121.4 .....	3	P820G1 .....	3
408.06 .....	2	P1020G .....	3	P1121G .....	3	P821 .....	3
MS200 .....	3	P10211 .....	3	P1121G1 .....	3	P821G .....	3

Manufacturer Line Number	Inner Set	Outer Set	Inner (Cone/Cup)	Outer (Cone/Cup)				
					Timken	National	Stemco	SKF

**MACK MID-LINER**

<b>3</b>	DRIVE AXLE .....	-	-	594	594	-	-	-	-
		-	-	593X	593X	-	-	-	-

**MERCEDES Axle Model Index**

Model	Line No.	Model	Line No.	Model	Line No.	Model	Line No.
L1013 .....	1	L1116 .....	1	L1316 .....	3	LS1316 .....	5
L1113 .....	1	L1117 .....	2	L1418 .....	4	LS1418 .....	6

HEAVY-DUTY WHEEL BEARING APPLICATIONS

Manufacturer Line Number	Inner Set	Outer Set	Inner (Cone/Cup)	Outer (Cone/Cup)	Timken	National	Stemco	SKF

**MERCEDES**

3

FRONT AXLE .....	-	-	559	-	-	-	-	-
	-	-	552A	-	-	-	-	-
743.11 RATIO 7.43 FROM CHASSIS NO. 518923 .....	-	-	-	-	-	-	-	-
	-	-	598A	-	-	-	-	-
	-	-	593X	-	-	-	-	-

4

FRONT AXLE .....	-	-	559	-	-	-	-	-
	-	-	552A	-	-	-	-	-

5

FRONT AXLE .....	-	-	559	-	-	-	-	-
	-	-	552A	-	-	-	-	-

6

FRONT AXLE .....	-	-	559	-	-	-	-	-
	-	-	552A	-	-	-	-	-

**NEOAX Axle Model Index**

Model	Line No.	Model	Line No.	Model	Line No.	Model	Line No.
F3W-1200 .....	1	F3W-1200 .....	1	F3W-1400 .....	1	F6W-1400 .....	1

Manufacturer Line Number	Inner Set	Outer Set	Inner (Cone/Cup)	Outer (Cone/Cup)	Timken	National	Stemco	SKF

**NEOAX**

1

FRONT AXLE .....	-	Set406	HM212049	3782	-	-	-	-
	-	-	HM212011	3720	-	-	-	-

**OSHKOSH Axle Model Index**

Model	Line No.	Model	Line No.	Model	Line No.	Model	Line No.
10338-F-5 .....	1	17896-F .....	5	3908-F-2 .....	9	W-212 .....	15
1258-HA-2 .....	20	1880-G-2 .....	22	6757-G-2 .....	23	W-2200 .....	16
1554-GA-1 .....	2	1888-G-4 .....	6	7895-G .....	10	W-2200 .....	17
1555-G .....	21	1916-J .....	7	8000-G .....	11	W-2200 .....	24
15640-F-1 .....	3	1916-J .....	8	H-1700 .....	12	W-2204 .....	25
16800-F .....	3	19850-F .....	8	W-1600 .....	13	W-700 .....	18
1747-J .....	4	2346-F-3 .....	8	W-1700 .....	14	W-900 .....	19

Manufacturer Line Number	Inner Set	Outer Set	Inner (Cone/Cup)	Outer (Cone/Cup)	Timken	National	Stemco	SKF

**OSHKOSH**

1

FRONT AXLE .....	-	-	687	687	-	-	-	-
	-	-	672	672	-	-	-	-

2

FRONT AXLE .....	-	-	780	687	-	-	-	-
	-	-	772	672	-	-	-	-

3

FRONT AXLE .....	-	-	687	687	-	-	-	-
	-	-	672	672	-	-	-	-

4

FRONT AXLE .....	-	-	5760	567	-	-	-	-
	-	-	5735	563A	-	-	-	-

Manufacturer Line Number	Inner Set	Outer Set	Inner (Cone/Cup)	Outer (Cone/Cup)	Timken	National	Stemco	SKF

**OSHKOSH (continued)**

<b>5</b>								
FRONT AXLE .....	-	-	687	687	-	-	-	-
	-	-	672	672	-	-	-	-
<b>6</b>								
FRONT AXLE .....	-	-	780	687	-	-	-	-
	-	-	772	672	-	-	-	-
<b>7</b>								
FRONT AXLE .....	-	-	687	687	-	-	-	-
	-	-	672	672	-	-	-	-
<b>8</b>								
FRONT AXLE .....	-	-	687	687	-	-	-	-
	-	-	672	672	-	-	-	-
<b>9</b>								
FRONT AXLE .....	-	-	687	687	-	-	-	-
	-	-	672	672	-	-	-	-
<b>10</b>								
FRONT AXLE .....	-	-	71455	71455	-	-	-	-
	-	-	71750	71750	-	-	-	-
<b>11</b>								
FRONT AXLE .....	-	-	67389	47690A	-	-	-	-
	-	-	67322	47620	-	-	-	-
<b>12</b>								
FRONT AXLE .....	-	-	687	687	-	-	-	-
	-	-	672	672	-	-	-	-
<b>13</b>								
FRONT AXLE .....	-	-	780	687	-	-	-	-
	-	-	772	672	-	-	-	-
<b>14</b>								
FRONT AXLE .....	-	-	687	687	-	-	-	-
	-	-	672	672	-	-	-	-
<b>15</b>								
FRONT AXLE .....	-	-	5760	567	-	-	-	-
	-	-	5735	563A	-	-	-	-
<b>16</b>								
FRONT AXLE .....	-	-	780	687	-	-	-	-
	-	-	772	672	-	-	-	-
<b>17</b>								
FRONT AXLE .....	-	-	780	687	-	-	-	-
	-	-	772	672	-	-	-	-
<b>18</b>								
FRONT AXLE .....	-	-	687	687	-	-	-	-
	-	-	672	672	-	-	-	-
<b>19</b>								
FRONT AXLE .....	-	-	780	687	-	-	-	-
	-	-	772	672	-	-	-	-
<b>20</b>								
REAR AXLE .....	-	-	749	749	-	-	-	-
	-	-	742	742	-	-	-	-

HEAVY-DUTY WHEEL BEARING APPLICATIONS

Manufacturer Line Number	Inner Set	Outer Set	Inner (Cone/Cup)	Outer (Cone/Cup)	Timken	National	Stemco	SKF

**OSHKOSH** (continued)

<b>21</b>	REAR AXLE .....	-	-	71450	71450	-	-	-	-
		-	-	71750	71750	-	-	-	-
<b>22</b>	REAR AXLE .....	-	-	780	687	-	-	-	-
		-	-	772	672	-	-	-	-
<b>23</b>	REAR AXLE .....	-	-	99600	HM237545	-	-	-	-
		-	-	99100	HM237510	-	-	-	-
<b>24</b>	REAR AXLE .....	-	-	780	687	-	-	-	-
		-	-	772	672	-	-	-	-
<b>25</b>	REAR AXLE .....	-	-	71450	71450	-	-	-	-
		-	-	71750	71750	-	-	-	-

**PAGE & PAGE Axle Model Index**

Model	Line No.	Model	Line No.	Model	Line No.	Model	Line No.
A-60 .....	1						

Manufacturer Line Number	Inner Set	Outer Set	Inner (Cone/Cup)	Outer (Cone/Cup)	Timken	National	Stemco	SKF

**PAGE & PAGE**

<b>1</b>	TRAILER AXLE .....	-	-	896	6580	-	-	-	-
		-	-	893	6535	-	-	-	-

**ROCKWELL-See ARVINMERITOR Axle Model Index**

Model	Line No.	Model	Line No.	Model	Line No.	Model	Line No.
16910 .....	1	ERQHD .....	44	FDS-75 .....	20	FU-900 .....	33
16930 .....	1	F-106 .....	45	FE-900 .....	21	FU-910 .....	33
16931 .....	1	F-140 .....	46	FE-903 .....	21	FV SERIES .....	191
17100 .....	2	F-145 .....	47	FE-970 .....	22	G-161 .....	50
1758 .....	37	F-147 .....	47	FE-971 .....	22	G-361 .....	50
26061 .....	3	F-2090 .....	9	FF-901 .....	23	H-100 .....	51
2665 .....	4	F-2094 .....	9	FF-903 .....	23	H-140 .....	52
27061 .....	5	F-223 .....	10	FF-921 .....	23	H-141 .....	53
27460 .....	6	F-233 .....	10	FF-923 .....	23	H-143 .....	54
27462 .....	6	F-235 .....	11	FF-931 .....	23	H-162 .....	55
31116 .....	7	F-3110 .....	12	FF-931A .....	23	H-170 .....	56
32500 .....	8	F-3200 .....	12	FF-932 .....	24	H-171 .....	57
32550 .....	8	F-340 .....	48	FF-941 .....	24	H-172 .....	58
32552 .....	8	F-345 .....	49	FF-942 .....	24	H-340 .....	59
32553 .....	8	F-409 .....	12	FF-961 .....	24	H-341 .....	60
58822/3 .....	38	F-429W .....	12	FG-900 .....	25	H-362 .....	61
58863 .....	39	F-7900 .....	13	FG-903 .....	25	L-100 .....	62
58873 .....	39	FC-900 .....	14	FG-931 .....	26	L-101 .....	62
59000 .....	40	FC-901 .....	14	FG-941 .....	26	L-140 .....	63
59722 .....	40	FC-903 .....	14	FG-942 .....	27	L-145 .....	63
59723 .....	40	FC-931 .....	15	FH-900 .....	28	L-146 .....	63
61142/61143 .....	40	FD-900 .....	16	FH-901 .....	28	L-148 .....	64
C-100 .....	41	FD-901 .....	16	FL-900 .....	29	L-155 .....	65
D-100 .....	41	FD-903 .....	16	FL-901 .....	29	L-160 .....	66
D-140 .....	41	FD-931 .....	16	FL-931 .....	29	L-162 .....	66
E-100 .....	41	FD-961 .....	17	FL-942 .....	30	L-172 .....	67
E-200 .....	41	FDS-1600 .....	18	FL-951 .....	31	L-245 .....	68
ELHD .....	42	FDS-1800 SERIES .....	19	FQ-901 .....	32	L-340 .....	68
ERLHD .....	43	FDS-2100 SERIES .....	19	FQ-921 .....	32	L-345 .....	69

**ROCKWELL-See ARVINMERITOR Axle Model Index (continued)**

Model	Line No.	Model	Line No.	Model	Line No.	Model	Line No.
L-346	69	RF-16-145	35	SFD-157	140	SW-3458	181
L-362	70	RF-21-155	35	SFD-3020	141	SW-456	182
L-365	71	RF-21-156	35	SFD-4600	142	SW-457	182
PR-223	72	RF-21-355	35	SFD-4640	142	SW-458	182
PR-400	73	RF-23-180	35	SFD-4740	143	T-11301	193
PR-700	74	RF-7-106	36	SFDD-4640	144	T-14000	194
Q-100	75	RF-9-106	36	SFDD-4740	145	T-17000 SERIES	195
Q-145	75	RL-170	107	SFDD-4742	145	T-2067	196
Q-148	76	RL SERIES	191	SFHD	146	THD SERIES	197
Q-245	77	RN SERIES	192	SHHD	147	TH SERIES	197
Q-246	77	RQ SERIES	192	SJHD	148	TKD SERIES	199
Q-345	77	RS-13-120	108	SL-100	149	TKLD SERIES	200
Q-346	77	RS-15-120	109	SL-100-P	149	TKL SERIES	200
QT-140	78	RS-15-210	110	SLD	150	TKNC SERS.	202
QT-240	79	RS-17-140	111	SLDD	150	TKND SERS.	203
QT-300	80	RS-17-145	111	SLHD	151	TKN SERIES	201
QT-301	80	RS-17-220	112	SPR250	155	TK SERS.	198
QT-340	81	RS-19-145	113	SPR-400	152	TLD SERIES	204
QT-365	81	RS-19-220	114	SPR-570	153	TL SERIES	204
QWF	82	RS-21-145	115	SPR-700	154	TM SERS.	205
QWR	82	RS-21-230	116	SPRC-1926	156	TNC SERIES	206
R-100	83	RS-23-160	117	SPRC-1927	156	TND SERIES	206
R-114	84	RS-23-161	117	SPRC-4806	157	TN SERIES	206
R-115	84	RS-23-180	117	SQ-100	158	TP SERS.	207
R-120	85	RS-23-240	118	SQ-100-P	158	TQD SERIES	208
R-140	86	RS-23-380	119	SQD	159	TQ SERIES	208
R-141	87	RS-26-160	120	SQDD	160	TRD SERIES	209
R-155	88	RS-26-180	120	SQHD	161	TR SERIES	209
R-160	89	RS-26-380	120	SQHP	162	TU SERS.	210
R-163	90	RS-30-180	121	SQR-100	163	TW SERS.	211
R-170	91	RS-30-380	122	SQR-100-P	163	U-170	183
R-171	92	RS-38-380	123	SQW	164	U-180	184
R-173	93	RT-240	124	SR-170	165	U-200	185
R-200	94	RT-241	125	SR-270	166	U-200A	185
R-200A	95	RT-243	125	SR-280	167	U-240	186
R-202	96	RT-265	126	SRD	168	U-270	187
R-210	97	RT-340	128	SRDD	169	U-300	188
R-210A	97	RT-341	128	SRHD	169	U-300A	188
R-220	98	RT-34-145	127	SSHD	170	W-170	189
R-221	99	RT-343	128	SSHP	171	W-270	190
R-221	100	RT-365	129	ST-170	172		
R-230	100	RT-40-145	130	ST-270	173		
R-230A	100	RT-44-145	130	ST-280	173		
R-255	100	RT-46-160	130	STD	174		
R-270	101	RT-48-180	131	STDD	174		
R-300	102	RT-48-380	132	STHD	175		
R-302	103	RT-52-160	133	SU-170	176		
R-314W	104	RT-52-180	133	SU-270	176		
R-315	104	RT-52-380	134	SU-280	177		
R-320	105	RT-58-180	135	SUD	178		
R-321	105	RT-58-380	135	SUDD	178		
R-330	105	RT-70-380	136	SUHD	179		
R-330A	105	S-170	137	SW-170	180		
R-390	106	SD-436	138	SW-270	180		
RF-12-125	34	SDHD	139	SW-280	180		

Manufacturer Line Number	Inner Set	Outer Set	Inner (Cone/Cup)	Outer (Cone/Cup)				
					Timken	National	Stemco	SKF

**ROCKWELL-See ARVINMERITOR**

<b>1</b>	FRONT AXLE	-	-	6379	557S	-	370066A	-	40086
		-	-	6320	552A	-	-	-	-

<b>2</b>	FRONT AXLE	-	-	6389	557S	-	-	-	-
		-	-	6320	552A	-	-	-	-

HEAVY-DUTY WHEEL BEARING APPLICATIONS

Manufacturer Line Number	Inner Set	Outer Set	Inner (Cone/Cup)	Outer (Cone/Cup)	Timken	National	Stemco	SKF

**ROCKWELL-See ARVINMERITOR** (continued)

<b>3</b>								
FRONT AXLE .....	-	-	6375	59175	-	-	-	-
	-	-	6320	59412	-	-	-	-
<b>4</b>								
FRONT AXLE .....	-	-	6379	555-S	-	370066A	-	40086
	-	-	6320	552A	-	-	-	-
<b>5</b>								
FRONT AXLE .....	-	-	6379	537	-	370165A	-	38747
	-	-	6320	532A	-	-	-	-
<b>6</b>								
FRONT AXLE .....	-	-	6389	537	-	370165A	-	38747
	-	-	6320	532A	-	-	-	-
<b>7</b>								
FRONT AXLE .....	-	-	3578	2689	-	-	-	-
	-	-	3525	2631	-	-	-	-
<b>8</b>								
FRONT AXLE .....	-	-	3778	2790	-	-	-	-
	-	-	3720	2720	-	-	-	-
<b>9</b>								
FRONT DRIVE AXLE .....	-	-	594	498	-	-	-	-
	-	-	592A	493	-	-	-	-
<b>10</b>								
FRONT DRIVE AXLE .....	-	-	71450	52400	-	-	-	-
	-	-	71750	52637	-	-	-	-
<b>11</b>								
FRONT DRIVE AXLE .....	-	-	64450	52400	-	-	-	-
	-	-	64700	52637	-	-	-	-
<b>12</b>								
FRONT DRIVE AXLE .....	-	-	71450	52400	-	-	-	-
	-	-	71750	52637	-	-	-	-
<b>13</b>								
FRONT DRIVE AXLE .....	-	-	64450	52400	-	-	-	-
	-	-	64700	52638	-	-	-	-
<b>14</b>								
FRONT AXLE .....	Set410	-	45284	-	-	370010A	-	28820
	-	-	45220	-	-	-	-	-
FRONT AXLE - THRU 8-72 .....	-	-	-	2780	-	370010A	-	28820
	-	-	-	2720	-	-	-	-
FRONT AXLE - 9-72 ON .....	-	-	-	25880	-	370054A	-	28832
	-	-	-	25820	-	-	-	-
<b>15</b>								
FRONT AXLE .....	-	-	39581	3585	-	370132A	308-0863	34975
	-	-	39520	3525	-	-	-	-
<b>16</b>								
FRONT AXLE .....	-	-	39581	3585	TKR847	370001A	308-0836	35066
	-	-	39520	3525	-	-	-	-
<b>17</b>								
FRONT AXLE .....	Set412	Set406	HM212047	3782	TKR847	370001A	308-0836	35066
	-	-	HM212011	3720	-	-	-	-

Manufacturer Line Number	Inner Set	Outer Set	Inner (Cone/Cup)	Outer (Cone/Cup)	Timken	National	Stemco	SKF

**ROCKWELL-See ARVINMERITOR (continued)**

<b>18</b>	FRONT DRIVE AXLE .....	-	Set414	64450	HM218248	-	-	-	-
		-	-	64700	HM218210	-	-	-	-
<b>19</b>	FRONT DRIVE AXLE .....	-	-	JHM720249	52375	-	-	-	-
		-	-	JHM720210	52637	-	-	-	-
<b>20</b>	FRONT DRIVE AXLE .....	-	-	47490	395A	-	-	-	-
		-	-	47420	394A	-	-	-	-
<b>21</b>	FRONT AXLE .....	Set412	Set406	HM212047	3782	TKR847	370001A	308-0836	35066
		-	-	HM212011	3720	-	-	-	-
<b>22</b>	FRONT AXLE .....	-	Set412	756A	HM212047	-	370007A	-	48794
		-	-	752	HM212011	-	-	-	-
<b>23</b>	FRONT AXLE .....	Set412	Set406	HM212047	3782	TKR847	370001A	308-0836	35066
		-	-	HM212011	3720	-	-	-	-
<b>24</b>	FRONT AXLE .....	Set413	Set406	HM212049	3782	TKR847	370001A	308-0836	35066
		-	-	HM212011	3720	-	-	-	-
<b>25</b>	FRONT AXLE - SOME .....	-	-	6389	-	-	370008A	-	39380
		-	-	6320	-	-	-	-	-
	FRONT AXLE - OTHERS .....	-	-	6386	-	-	370008A	-	39380
		-	-	6320	-	-	-	-	-
	FRONT AXLE .....	-	-	-	537	-	370008A	-	39380
		-	-	-	532A	-	-	-	-
<b>26</b>	FRONT AXLE .....	Set413	Set406	HM212049	3782	TKR847	370001A	308-0836	35066
		-	-	HM212011	3720	-	-	-	-
<b>27</b>	FRONT AXLE .....	Set413	Set406	HM212049	3782	-	-	-	-
		-	-	HM212011	3720	-	-	-	-
<b>28</b>	FRONT AXLE .....	Set423	-	6461A	-	-	370182A	-	43764
		-	-	6420	-	-	-	-	-
	FRONT AXLE - EXC DIAMOND REO .....	-	-	-	3979	-	-	-	-
		-	-	-	3920	-	-	-	-
	FRONT AXLE - DIAMOND REO .....	-	-	-	555-S	-	370182A	-	43764
		-	-	-	552A	-	-	-	-
<b>29</b>	FRONT AXLE .....	Set423	-	6461A	555-S	-	370182A	-	43764
		-	-	6420	552A	-	-	-	-
<b>30</b>	FRONT AXLE .....	Set413	Set406	HM212049	3782	-	370182A	-	43764
		-	-	HM212011	3720	-	-	-	-
<b>31</b>	FRONT AXLE .....	Set423	-	6461A	555-S	-	370182A	-	43764
		-	-	6420	552A	-	-	-	-

HEAVY-DUTY WHEEL BEARING APPLICATIONS

Manufacturer Line Number	Inner Set	Outer Set	Inner (Cone/Cup)	Outer (Cone/Cup)	Timken	National	Stemco	SKF

**ROCKWELL-See ARVINMERITOR** (continued)

<b>32</b>	FRONT AXLE .....	-	-	766	JH211749	-	-	-	-
		-	-	752A	JH211710	-	-	-	-
<b>33</b>	FRONT AXLE .....	-	-	HH221442	749	-	-	-	-
		-	-	HH221410	742	-	-	-	-
<b>34</b>	FRONT DRIVE AXLE .....	-	-	JM612949C	JLM710949	-	-	-	-
		-	-	JM61290	JLM710910	-	-	-	-
<b>35</b>	FRONT DRIVE AXLE .....	-	-	JHM720249	52375	-	-	-	-
		-	-	JHM720210	52637	-	-	-	-
<b>36</b>	FRONT DRIVE AXLE .....	-	-	JM612949C	JLM710949	-	-	-	-
		-	-	JM61290	JLM710910	-	-	-	-
<b>37</b>	REAR AXLE .....	-	-	759	749	-	-	-	-
		-	-	752	742	-	-	-	-
<b>38</b>	REAR AXLE .....	Set405	Set405	663	663	-	-	-	-
		-	-	653	653	-	-	-	-
<b>39</b>	REAR AXLE .....	-	Set405	749A	663	-	-	-	-
		-	-	742	653	-	-	-	-
<b>40</b>	REAR AXLE .....	-	Set405	6580	663	-	-	-	-
		-	-	6535	653	-	-	-	-
<b>41</b>	REAR AXLE .....	-	-	3984	462	-	370046A	-	31307
		-	-	3920	453X	-	-	-	-
<b>42</b>	TANDEM REAR AXLE - THRU 1973 .....	Set402	-	582	42687	-	370030A	309-0961	42800
		-	-	572	42620	-	-	-	-
	TANDEM REAR AXLE - 1974 ON .....	Set411	Set408	47686	39590	-	-	-	-
		-	-	47620	39520	-	-	-	-
<b>43</b>	TANDEM REAR AXLE - Thru 7-81 RDHD .....	Set404	-	598A	-	-	370030A	309-0961	42800
		-	-	592A	-	-	-	-	-
	TANDEM REAR AXLE - 8-81 On SRHD .....	Set403	-	594A	-	-	370030A	309-0961	42800
		-	-	592A	-	-	-	-	-
	TANDEM REAR AXLE - SRHD .....	-	Set401	-	580	-	370030A	309-0961	42800
		-	-	-	572	-	-	-	-
	TANDEM REAR AXLE - SLHD .....	Set402	-	582	42687	-	370030A	309-0961	42800
		-	-	582	42687	-	-	-	-
		-	-	572	42620	-	-	-	-
		-	-	572	42620	-	-	-	-
<b>44</b>	TANDEM REAR AXLE - THRU 7-81 .....	Set404	-	598A	-	-	370030A	309-0961	42800
		-	-	592A	-	-	-	-	-
	TANDEM REAR AXLE - 8-81 ON .....	Set403	-	594A	-	-	370030A	309-0961	42800
		-	-	592A	-	-	-	-	-

Manufacturer Line Number	Inner Set	Outer Set	Inner (Cone/Cup)	Outer (Cone/Cup)	Timken	National	Stemco	SKF

**ROCKWELL-See ARVINMERITOR (continued)**

TANDEM REAR AXLE .....	-	Set401	-	580	-	370030A	309-0961	42800
	-	-	-	572	-	-	-	-
<b>45</b>								
REAR AXLE - STD .....	-	-	33287	3982	-	370047A	309-0935	34384
	-	-	33462	3920	-	-	-	34387
<b>46</b>								
REAR AXLE - STD .....	-	-	33287	3982	-	370047A	309-0935	34384
	-	-	33462	3920	-	-	-	34387
REAR AXLE - DUPLEX-F-140 AXL .....	-	-	33281	3982	-	370047A	309-0935	34384
	-	-	33462	3920	-	-	-	34387
<b>47</b>								
REAR AXLE - STD .....	-	-	33287	3982	-	370047A	309-0935	34384
	-	-	33462	3920	-	-	-	34387
<b>48</b>								
REAR AXLE - STD .....	-	-	33287	3982	-	370047A	309-0935	34384
	-	-	33462	3920	-	-	-	34387
REAR AXLE - DUPLEX-F-340 AXLE .....	-	-	33281	3982	-	370047A	309-0935	34384
	-	-	33462	3920	-	-	-	34387
<b>49</b>								
REAR AXLE - STD .....	-	-	33287	3982	-	370047A	309-0935	34384
	-	-	33462	3920	-	-	-	34387
<b>50</b>								
REAR AXLE .....	-	-	M514546	M111048	-	-	-	-
	-	-	M514512	M111012	-	-	-	-
<b>51</b>								
REAR AXLE .....	-	-	495AX	3984	-	370008A	-	39380
	-	-	493	3920	-	-	-	-
<b>52</b>								
REAR AXLE - STD .....	-	-	495AX	3984	-	370008A	-	39380
	-	-	493	3920	-	-	-	-
REAR AXLE - GMC .....	-	Set408	495AX	39590	-	370008A	-	39380
	-	-	493	39520	-	-	-	-
<b>53</b>								
REAR AXLE .....	-	Set408	42688	39590	-	370033A	-	38709
	-	-	42620	39520	-	-	-	-
<b>54</b>								
REAR AXLE .....	-	Set408	575S	39590	-	-	-	-
	-	-	572	39520	-	-	-	-
<b>55</b>								
REAR AXLE - STD .....	-	-	495AX	3984	-	370008A	-	39380
	-	-	493	3920	-	-	-	-
REAR AXLE - GMC .....	-	Set408	495AX	39590	-	370008A	-	39380
	-	-	493	39520	-	-	-	-
<b>56</b>								
REAR AXLE - STD .....	-	Set408	495AX	39590	-	370009A	309-0957	37425
	-	-	493	39520	-	-	-	39420
REAR AXLE - FORD .....	-	-	495AX	3984	-	370009A	309-0957	37425
	-	-	493	3920	-	-	-	39420
<b>57</b>								
REAR AXLE .....	-	Set408	42688	39590	-	370009A	309-0957	37425
	-	-	42620	39520	-	-	-	39420

HEAVY-DUTY WHEEL BEARING APPLICATIONS

Manufacturer Line Number	Inner Set	Outer Set	Inner (Cone/Cup)	Outer (Cone/Cup)	Timken	National	Stemco	SKF

**ROCKWELL-See ARVINMERITOR** (continued)

<b>58</b>								
REAR AXLE - STD .....	-	-	495AX	3984	-	370009A	309-0957	37425
	-	-	493	3920	-	-	-	39420
REAR AXLE - DODGE .....	-	Set408	42688	39590	-	370009A	309-0957	37425
	-	-	42620	39520	-	-	-	39420
<b>59</b>								
REAR AXLE - STD .....	-	-	495AX	3984	-	370008A	-	39380
	-	-	493	3920	-	-	-	-
REAR AXLE - GMC .....	-	Set408	495AX	39590	-	370008A	-	39380
	-	-	493	39520	-	-	-	-
<b>60</b>								
REAR AXLE .....	-	Set408	42688	39590	TKR861	370003A	309-0973	47697
	-	-	42620	39520	-	-	-	-
<b>61</b>								
REAR AXLE .....	-	Set408	495AX	39590	-	370008A	-	39380
	-	-	493	39520	-	-	-	-
<b>62</b>								
REAR AXLE - 1974 ON .....	Set411	Set408	47686	39590	-	370030A	309-0961	42800
	-	-	47620	39520	-	-	-	-
REAR AXLE - THRU 1973 .....	Set402	-	582	42687	-	370030A	309-0961	42800
	-	-	572	42620	-	-	-	-
<b>63</b>								
REAR AXLE - STD; THRU 1973 .....	Set402	-	582	42687	-	370030A	309-0961	42800
	-	-	572	42620	-	-	-	-
REAR AXLE - DODGE-SOME; THRU 1973 .....	Set411	Set408	47686	39590	-	370030A	309-0961	42800
	-	-	47620	39520	-	-	-	-
REAR AXLE - STD; ALL 1974 ON .....	Set411	Set408	47686	39590	-	370030A	309-0961	42800
	-	-	47620	39520	-	-	-	-
<b>64</b>								
REAR AXLE - THRU 1973 .....	-	-	663A	42687	-	370030A	309-0961	42800
	-	-	653	42620	-	-	-	-
REAR AXLE - 1974 ON .....	Set411	Set408	47686	39590	-	370030A	309-0961	42800
	-	-	47620	39520	-	-	-	-
<b>65</b>								
REAR AXLE - STD; THRU 1973 .....	Set402	-	582	42687	-	370030A	309-0961	42800
	-	-	572	42620	-	-	-	-
REAR AXLE - DODGE-SOME; THRU 1973 .....	Set411	Set408	47686	39590	-	370030A	309-0961	42800
	-	-	47620	39520	-	-	-	-
REAR AXLE - STD; ALL 1974 ON .....	Set411	Set408	47686	39590	-	370030A	309-0961	42800
	-	-	47620	39520	-	-	-	-
<b>66</b>								
REAR AXLE .....	Set411	Set408	47686	39590	TKR848	370024A	309-0915	38750
	-	-	47620	39520	-	-	-	-
<b>67</b>								
REAR AXLE - STD .....	Set411	Set408	47686	39590	TKR849	370023A	309-0912	38780
	-	-	47620	39520	-	-	-	-
<b>68</b>								
REAR AXLE - THRU 1973 .....	Set402	-	582	42687	-	370030A	309-0961	42800
	-	-	572	42620	-	-	-	-
REAR AXLE - 1974 ON .....	Set411	Set408	47686	39590	-	370030A	309-0961	42800
	-	-	47620	39520	-	-	-	-
<b>69</b>								
REAR AXLE - STD; THRU 1973 .....	Set402	-	582	42687	-	370030A	309-0961	42800
	-	-	572	42620	-	-	-	-

Manufacturer Line Number	Inner Set	Outer Set	Inner (Cone/Cup)	Outer (Cone/Cup)				
					Timken	National	Stemco	SKF

**ROCKWELL-See ARVINMERITOR (continued)**

REAR AXLE - DODGE, FORD, IHC & OSHKOSH; THRU 1973 .....	- Set411	- Set408	- 47686 47620	- 39590 39520	- -	- 370030A	- 309-0961	- 42800
REAR AXLE - STD; ALL 1974 ON .....	Set411	Set408	47686 47620	39590 39520	- -	370030A	309-0961	42800

<b>70</b> REAR AXLE .....	Set411	Set408	47686 47620	39590 39520	TKR848 -	370024A	309-0915	38750
------------------------------	--------	--------	----------------	----------------	-------------	---------	----------	-------

<b>71</b> REAR AXLE - STD; THRU 1973 .....	Set402	-	582 572	42687 42620	- -	370030A	309-0961	42800
REAR AXLE - DODGE, FORD, IHC & OSHKOSH; THRU 1973 .....	Set411	Set408	47686 47620	39590 39520	- -	370030A	309-0961	42800
REAR AXLE - STD; ALL 1974 ON .....	Set411	Set408	47686 47620	39590 39520	- -	370030A	309-0961	42800

<b>72</b> PLANETARY REAR AXLES .....	-	-	48290 48220	48290 48220	- -	-	-	-
---	---	---	----------------	----------------	--------	---	---	---

<b>73</b> PLANETARY REAR AXLES .....	-	-	67390 67322	67391 67322	- -	-	-	-
---	---	---	----------------	----------------	--------	---	---	---

<b>74</b> PLANETARY REAR AXLES .....	-	-	M238849 M238810	M238849 M238810	- -	-	-	-
---	---	---	--------------------	--------------------	--------	---	---	---

<b>75</b> REAR AXLE .....	Set404	Set401	598A 592A	580 572	- -	370030A	309-0961	42800
------------------------------	--------	--------	--------------	------------	--------	---------	----------	-------

<b>76</b> REAR AXLE .....	-	Set401	681A 672	580 572	- -	370006A	309-0970	47699
------------------------------	---	--------	-------------	------------	--------	---------	----------	-------

<b>77</b> REAR AXLE - STD .....	Set404	Set401	598A 592A	580 572	TKR861 -	370003A	309-0973	47697
REAR AXLE - FORD .....	-	-	598 592A	575 572	TKR861 -	370003A	309-0973	47697
REAR AXLE - IHC .....	Set403	Set401	594A 592A	580 572	TKR861 -	370003A	309-0973	47697

<b>78</b> REAR AXLE .....	Set404	Set401	598A 592A	580 572	- -	370030A	309-0961	42800
------------------------------	--------	--------	--------------	------------	--------	---------	----------	-------

<b>79</b> REAR AXLE - STD .....	Set404	Set401	598A 592A	580 572	TKR861 -	370003A	309-0973	47697
REAR AXLE - IHC .....	Set403	Set401	594A 592A	580 572	TKR861 -	370003A	309-0973	47697
REAR AXLE - WHITE .....	-	Set401	681A 672	580 572	TKR861 -	370003A	309-0973	47697

<b>80</b> REAR AXLE .....	Set404	Set401	598A 592A	580 572	TKR861 -	370003A	309-0973	47697
------------------------------	--------	--------	--------------	------------	-------------	---------	----------	-------

<b>81</b> REAR AXLE - STD .....	Set404	Set401	598A 592A	580 572	TKR861 -	370003A	309-0973	47697
------------------------------------	--------	--------	--------------	------------	-------------	---------	----------	-------

HEAVY-DUTY WHEEL BEARING APPLICATIONS

Manufacturer Line Number	Inner Set	Outer Set	Inner (Cone/Cup)	Outer (Cone/Cup)	Timken	National	Stemco	SKF

**ROCKWELL-See ARVINMERITOR** (continued)

REAR AXLE - IHC .....	Set403	Set401	594A 592A	580 572	TKR861 -	370003A -	309-0973 -	47697 -
REAR AXLE - WHITE .....	-	Set401	681A 672	580 572	TKR861 -	370003A -	309-0973 -	47697 -

**82**

TANDEM REAR AXLE - THRU 7-81 .....	Set404	-	598A 592A	- -	TKR861 -	370003A -	309-0973 -	47697 -
TANDEM REAR AXLE - 8-81 ON .....	Set403	-	594A 592A	- -	TKR861 -	370003A -	309-0973 -	47697 -
TANDEM REAR AXLE .....	-	Set401	-	580 572	TKR861 -	370003A -	309-0973 -	47697 -

**83**

REAR AXLE .....	Set404	Set401	598A 592A	580 572	TKR861 -	370003A -	309-0973 -	47697 -
-----------------	--------	--------	--------------	------------	-------------	--------------	---------------	------------

**84**

REAR AXLE .....	-	Set405	6559 6536	663 653	- -	370178A -	- -	44964 -
-----------------	---	--------	--------------	------------	--------	--------------	--------	------------

**85**

REAR AXLE .....	Set404	Set401	598A 592A	580 572	TKR861 -	370003A -	309-0973 -	47697 -
-----------------	--------	--------	--------------	------------	-------------	--------------	---------------	------------

**86**

REAR AXLE .....	Set404	Set401	598A 592A	580 572	- -	370030A -	309-0961 -	42800 -
-----------------	--------	--------	--------------	------------	--------	--------------	---------------	------------

**87**

REAR AXLE .....	-	Set401	594 592A	580 572	TKR858 -	370021A -	309-0964 -	45160 -
-----------------	---	--------	-------------	------------	-------------	--------------	---------------	------------

**88**

REAR AXLE - STD THRU 1983 .....	Set404	-	598A 592A	- -	- -	370030A -	309-0961 -	42800 -
REAR AXLE - STD 1984 ON .....	Set403	-	594A 592A	- -	- -	370030A -	309-0961 -	42800 -
REAR AXLE - H.D. ....	-	-	681A 672	- -	- -	370030A -	309-0961 -	42800 -
REAR AXLE .....	-	Set401	-	580 572	- -	370030A -	309-0961 -	42800 -

**89**

REAR AXLE .....	Set404	Set401	598A 592A	580 572	- -	370030A -	309-0961 -	42800 -
-----------------	--------	--------	--------------	------------	--------	--------------	---------------	------------

**90**

REAR AXLE .....	-	Set401	681A 672	580 572	- -	370006A -	309-0970 -	47699 -
-----------------	---	--------	-------------	------------	--------	--------------	---------------	------------

**91**

REAR AXLE - STD; THRU 2-81 .....	Set404	-	598A 592A	- -	- -	370030A -	309-0961 -	42800 -
REAR AXLE - STD; 3-81 ON .....	Set403	-	594A 592A	- -	- -	370030A -	309-0961 -	42800 -
REAR AXLE - STD .....	-	Set401	-	580 572	TKR861 -	370003A -	309-0973 -	47697 -
REAR AXLE - H.D. ....	-	Set401	681A 672	580 572	- -	370030A -	309-0961 -	42800 -
REAR AXLE - FORD 4-76 ON .....	Set403	Set401	594A 592A	580 572	TKR861 -	370003A -	309-0973 -	47697 -
REAR AXLE - GMC .....	-	Set401	594 592A	580 572	TKR861 -	370003A -	309-0973 -	47697 -

Manufacturer Line Number	Inner Set	Outer Set	Inner (Cone/Cup)	Outer (Cone/Cup)				
					Timken	National	Stemco	SKF

**ROCKWELL-See ARVINMERITOR (continued)**

<b>92</b>									
REAR AXLE - STD .....	-	Set401	594	580	TKR861	370003A	309-0973	47697	
	-	-	592A	572	-	-	-	-	
REAR AXLE - FORD 4-76 ON .....	Set403	Set401	594A	580	TKR861	370003A	309-0973	47697	
	-	-	592A	572	-	-	-	-	
<b>93</b>									
REAR AXLE .....	-	Set401	681A	580	-	370006A	309-0970	47699	
	-	-	672	572	-	-	-	-	
<b>94</b>									
REAR AXLE - STD ;THRU 1983 .....	Set404	-	598A	-	-	370030A	309-0961	42800	
	-	-	592A	-	-	-	-	-	
REAR AXLE - STD; 1984 ON .....	Set403	-	594A	-	-	370030A	309-0961	42800	
	-	-	592A	-	-	-	-	-	
REAR AXLE - STD .....	-	Set401	-	580	-	370030A	309-0961	42800	
	-	-	-	572	-	-	-	-	
REAR AXLE - WHITE-SOME .....	-	Set401	681A	580	-	370030A	309-0961	42800	
	-	-	672	572	-	-	-	-	
<b>95</b>									
REAR AXLE - STD ;THRU 1983 .....	Set404	-	598A	-	-	370006A	309-0970	47699	
	-	-	592A	-	-	-	-	-	
REAR AXLE - STD; 1984 ON .....	Set403	-	594A	-	-	370006A	309-0970	47699	
	-	-	592A	-	-	-	-	-	
REAR AXLE - STD .....	-	Set401	-	580	-	370006A	309-0970	47699	
	-	-	-	572	-	-	-	-	
REAR AXLE - WHITE-SOME .....	-	Set401	681A	580	-	370006A	309-0970	47699	
	-	-	672	572	-	-	-	-	
<b>96</b>									
REAR AXLE .....	-	Set401	594	580	-	370030A	309-0961	42800	
	-	-	592A	572	-	-	-	-	
<b>97</b>									
REAR AXLE .....	-	Set401	681A	580	-	370006A	309-0970	47699	
	-	-	672	572	-	-	-	-	
<b>98</b>									
REAR AXLE - STD ;THRU 1983 .....	Set404	-	598A	-	-	370030A	309-0961	42800	
	-	-	592A	-	-	-	-	-	
REAR AXLE - STD; 1984 ON .....	Set403	-	594A	-	-	370030A	309-0961	42800	
	-	-	592A	-	-	-	-	-	
REAR AXLE - STD .....	-	Set401	-	580	-	370030A	309-0961	42800	
	-	-	-	572	-	-	-	-	
REAR AXLE - WHITE-SOME .....	-	Set401	681A	580	-	370030A	309-0961	42800	
	-	-	672	572	-	-	-	-	
<b>99</b>									
REAR AXLE - STD ;THRU 1983 .....	Set404	-	598A	-	TKR861	370003A	309-0973	47697	
	-	-	592A	-	-	-	-	-	
REAR AXLE - STD; 1984 ON .....	Set403	-	594A	-	TKR861	370003A	309-0973	47697	
	-	-	592A	-	-	-	-	-	
REAR AXLE - STD .....	-	Set401	-	580	TKR861	370003A	309-0973	47697	
	-	-	-	572	-	-	-	-	
REAR AXLE - WHITE-SOME .....	-	Set401	681A	580	TKR861	370003A	309-0973	47697	
	-	-	672	572	-	-	-	-	
<b>100</b>									
REAR AXLE - STD ;THRU 1983 .....	Set404	-	598A	-	-	370030A	309-0961	42800	
	-	-	592A	-	-	-	-	-	

HEAVY-DUTY WHEEL BEARING APPLICATIONS

Manufacturer Line Number	Inner Set	Outer Set	Inner (Cone/Cup)	Outer (Cone/Cup)	Timken	National	Stemco	SKF

**ROCKWELL-See ARVINMERITOR** (continued)

REAR AXLE - STD; 1984 ON .....	Set403	-	594A	-	-	370030A	309-0961	42800
	-	-	592A	-	-	-	-	-
REAR AXLE - STD .....	-	Set401	-	580	-	370030A	309-0961	42800
	-	-	-	572	-	-	-	-
REAR AXLE - WHITE-SOME .....	-	Set401	681A	580	-	370030A	309-0961	42800
	-	-	672	572	-	-	-	-

**101**

REAR AXLE .....	Set403	Set401	594A	580	TKR861	370003A	309-0973	47697
	-	-	592A	572	-	-	-	-

**102**

REAR AXLE - STD ;THRU 1983 .....	Set404	-	598A	-	-	370030A	309-0961	42800
	-	-	592A	-	-	-	-	-
REAR AXLE - STD; 1984 ON .....	Set403	-	594A	-	-	370030A	309-0961	42800
	-	-	592A	-	-	-	-	-
REAR AXLE - STD .....	-	Set401	-	580	-	370030A	309-0961	42800
	-	-	-	572	-	-	-	-
REAR AXLE - WHITE-SOME .....	-	Set401	681A	580	-	370030A	309-0961	42800
	-	-	672	572	-	-	-	-

**103**

REAR AXLE .....	-	Set401	594	580	-	370030A	309-0961	42800
	-	-	592A	572	-	-	-	-

**104**

REAR AXLE .....	-	Set405	6559	663	-	-	-	-
	-	-	6535	653	-	-	-	-

**105**

REAR AXLE - STD ;THRU 1983 .....	Set404	-	598A	-	-	370030A	309-0961	42800
	-	-	592A	-	-	-	-	-
REAR AXLE - STD; 1984 ON .....	Set403	-	594A	-	-	370030A	309-0961	42800
	-	-	592A	-	-	-	-	-
REAR AXLE - STD .....	-	Set401	-	580	-	370030A	309-0961	42800
	-	-	-	572	-	-	-	-
REAR AXLE - WHITE-SOME .....	-	Set401	681A	580	-	370030A	309-0961	42800
	-	-	672	572	-	-	-	-

**106**

REAR AXLE .....	Set404	Set401	598A	580	TKR861	370003A	309-0973	47697
	-	-	592A	572	-	-	-	-

**107**

REAR AXLE - STD; THRU 2-81 .....	Set404	-	598A	-	-	370030A	309-0961	42800
	-	-	592A	-	-	-	-	-
REAR AXLE - STD; 3-81 ON .....	Set403	-	594A	-	-	370030A	309-0961	42800
	-	-	592A	-	-	-	-	-
REAR AXLE - STD .....	-	Set401	-	580	TKR861	370003A	309-0973	47697
	-	-	-	572	-	-	-	-
REAR AXLE - H.D. ....	-	Set401	681A	580	-	370030A	309-0961	42800
	-	-	672	572	-	-	-	-
REAR AXLE - FORD 4-76 ON .....	Set403	Set401	594A	580	TKR861	370003A	309-0973	47697
	-	-	592A	572	-	-	-	-
REAR AXLE - GMC .....	-	Set401	594	580	TKR861	370003A	309-0973	47697
	-	-	592A	572	-	-	-	-

**108**

REAR AXLE .....	-	-	33287	3982	-	370046A	-	31307
	-	-	33462	3920	-	-	-	-

**109**

REAR AXLE .....	-	-	33287	3982	-	370047A	309-0935	34384
	-	-	33462	3920	-	-	-	34387

Manufacturer Line Number	Inner Set	Outer Set	Inner (Cone/Cup)	Outer (Cone/Cup)	Timken	National	Stemco	SKF

**ROCKWELL-See ARVINMERITOR (continued)**

<b>110</b>								
REAR AXLE .....	-	-	33287	3982	-	370047A	309-0935	34384
	-	-	33462	3920	-	-	-	34387
<b>111</b>								
REAR AXLE .....	Set411	Set408	47686	39590	TKR849	370023A	309-0912	38780
	-	-	47620	39520	-	-	-	-
<b>112</b>								
REAR AXLE .....	Set411	Set408	47686	39590	TKR849	370023A	309-0912	38780
	-	-	47620	39520	-	-	-	-
<b>113</b>								
REAR AXLE .....	Set411	Set408	47686	39590	TKR861	370003A	309-0973	47697
	-	-	47620	39520	-	-	-	-
<b>114</b>								
REAR AXLE .....	Set411	Set408	47686	39590	TKR861	370003A	309-0973	47697
	-	-	47620	39520	-	-	-	-
<b>115</b>								
REAR AXLE .....	Set403	Set401	594A	580	TKR861	370003A	309-0973	47697
	-	-	592A	572	-	-	-	-
<b>116</b>								
REAR AXLE .....	Set403	Set401	594A	580	TKR861	370003A	309-0973	47697
	-	-	592A	572	-	-	-	-
<b>117</b>								
REAR AXLE .....	Set403	Set401	594A	580	TKR861	370003A	309-0973	47697
	-	-	592A	572	-	-	-	-
<b>118</b>								
REAR AXLE .....	Set403	Set401	594A	580	TKR861	370003A	309-0973	47697
	-	-	592A	572	-	-	-	-
<b>119</b>								
REAR AXLE .....	Set403	Set401	594A	580	TKR861	370003A	309-0973	47697
	-	-	592A	572	-	-	-	-
<b>120</b>								
REAR AXLE .....	Set403	Set401	594A	580	TKR861	370003A	309-0973	47697
	-	-	592A	572	-	-	-	-
<b>121</b>								
REAR AXLE - STD .....	-	-	782	749	-	370120A	-	55177
	-	-	772	742	-	-	-	-
<b>122</b>								
REAR AXLE .....	-	-	782	749	-	370120A	-	55177
	-	-	772	742	-	-	-	-
<b>123</b>								
REAR AXLE .....	-	-	782	6580	-	-	-	-
	-	-	772	6535	-	-	-	-
<b>124</b>								
REAR AXLE - STD .....	Set404	Set401	598A	580	-	370030A	309-0961	42800
	-	-	592A	572	-	-	-	-
REAR AXLE - BROCKWAY .....	-	Set401	681A	580	-	370030A	309-0961	42800
	-	-	672	572	-	-	-	-
REAR AXLE - FORD .....	-	Set401	594	580	-	370030A	309-0961	42800
	-	-	592A	572	-	-	-	-

HEAVY-DUTY WHEEL BEARING APPLICATIONS

Manufacturer Line Number	Inner Set	Outer Set	Inner (Cone/Cup)	Outer (Cone/Cup)	Timken	National	Stemco	SKF

**ROCKWELL-See ARVINMERITOR (continued)**

REAR AXLE - IHC .....	Set403	Set401	594A 592A	580 572	- -	370030A -	309-0961 -	42800 -
<b>125</b>								
REAR AXLE - STD .....	Set404	Set401	598A 592A	580 572	TKR861 -	370003A -	309-0973 -	47697 -
REAR AXLE - BROCKWAY .....	-	Set401	681A 672	580 572	TKR861 -	370003A -	309-0973 -	47697 -
REAR AXLE - FORD .....	-	Set401	594 592A	580 572	TKR861 -	370003A -	309-0973 -	47697 -
REAR AXLE - IHC .....	Set403	Set401	594A 592A	580 572	TKR861 -	370003A -	309-0973 -	47697 -
<b>126</b>								
REAR AXLE - STD .....	Set404	Set401	598A 592A	580 572	TKR858 -	370021A -	309-0964 -	45160 -
REAR AXLE - BROCKWAY .....	-	Set401	681A 672	580 572	TKR858 -	370021A -	309-0964 -	45160 -
REAR AXLE - FORD .....	-	Set401	594 592A	580 572	TKR858 -	370021A -	309-0964 -	45160 -
REAR AXLE - IHC .....	Set403	Set401	594A 592A	580 572	TKR858 -	370021A -	309-0964 -	45160 -
<b>127</b>								
TANDEM REAR AXLE .....	Set411	Set408	47686 47620	39590 39520	TKR849 -	370023A -	309-0912 -	38780 -
<b>128</b>								
REAR AXLE - STD .....	Set404	Set401	598A 592A	580 572	TKR861 -	370003A -	309-0973 -	47697 -
REAR AXLE - BROCKWAY .....	-	Set401	681A 672	580 572	TKR861 -	370003A -	309-0973 -	47697 -
REAR AXLE - FORD .....	-	Set401	594 592A	580 572	TKR861 -	370003A -	309-0973 -	47697 -
REAR AXLE - IHC .....	Set403	Set401	594A 592A	580 572	TKR861 -	370003A -	309-0973 -	47697 -
<b>129</b>								
REAR AXLE - STD .....	Set404	Set401	598A 592A	580 572	- -	370030A -	309-0961 -	42800 -
REAR AXLE - BROCKWAY .....	-	Set401	681A 672	580 572	- -	370030A -	309-0961 -	42800 -
REAR AXLE - FORD .....	-	Set401	594 592A	580 572	- -	370030A -	309-0961 -	42800 -
REAR AXLE - IHC .....	Set403	Set401	594A 592A	580 572	- -	370030A -	309-0961 -	42800 -
<b>130</b>								
TANDEM REAR AXLE .....	Set403	Set401	594A 592A	580 572	TKR861 -	370003A -	309-0973 -	47697 -
<b>131</b>								
TANDEM REAR AXLE .....	Set403	Set401	594A 592A	580 572	TKR861 -	370003A -	309-0973 -	47697 -
<b>132</b>								
TANDEM REAR AXLE .....	Set403	Set401	594A 592A	580 572	TKR861 -	370003A -	309-0973 -	47697 -
<b>133</b>								
TANDEM REAR AXLE .....	Set403	Set401	594A 592A	580 572	TKR861 -	370003A -	309-0973 -	47697 -

Manufacturer Line Number	Inner Set	Outer Set	Inner (Cone/Cup)	Outer (Cone/Cup)	Timken	National	Stemco	SKF

**ROCKWELL-See ARVINMERITOR (continued)**

<b>134</b>	TANDEM REAR AXLE .....	Set403 -	Set401 -	594A 592A	580 572	TKR861 -	370003A -	309-0973 -	47697 -
<b>135</b>	TANDEM REAR AXLE - STD .....	- -	- -	782 772	749 742	- -	- -	- -	- -
<b>136</b>	TANDEM REAR AXLE .....	- -	- -	782 772	6580 6535	- -	- -	- -	- -
<b>137</b>	REAR AXLE .....	Set403 -	Set401 -	594A 592A	580 572	TKR861 -	370003A -	309-0973 -	47697 -
<b>138</b>	TANDEM REAR AXLE .....	- -	- -	759 752	749 742	- -	370004A -	- -	48884 -
<b>139</b>	TANDEM REAR AXLE .....	- -	- -	33281 33462	3982 3920	- -	370047A -	309-0935 -	34384 34387
<b>140</b>	TANDEM REAR AXLE .....	- -	- -	5557 5520	5557 5520	- -	- -	- -	- -
<b>141</b>	TANDEM REAR AXLE .....	- -	- -	575 572	575 572	- -	370004A -	- -	48884 -
<b>142</b>	TANDEM REAR AXLE .....	- -	- -	760 752	749 742	- -	370004A -	- -	48884 -
<b>143</b>	TANDEM REAR AXLE .....	- -	- -	938 932	780 772	- -	- -	- -	- -
<b>144</b>	TANDEM REAR AXLE .....	- -	- -	760 752	749 742	- -	370004A -	- -	48884 -
<b>145</b>	TANDEM REAR AXLE .....	- -	- -	938 932	780 772	- -	- -	- -	- -
<b>146</b>	TANDEM REAR AXLE .....	- -	- -	33281 33462	3982 3920	- -	370008A -	- -	39380 -
<b>147</b>	TANDEM REAR AXLE - STD .....	- -	- -	495AX 493	3984 3920	- -	370008A -	- -	39380 -
	TANDEM REAR AXLE - DODGE & WHITE .....	- -	Set408 -	42688 42620	39590 39520	- -	370008A -	- -	39380 -
<b>148</b>	TANDEM REAR AXLE .....	Set402 -	- -	582 572	42687 42620	- -	370030A -	309-0961 -	42800 -
<b>149</b>	TANDEM REAR AXLE - STD .....	Set411 -	Set408 -	47686 47620	39590 39520	TKR849 -	370023A -	309-0912 -	38780 -

HEAVY-DUTY WHEEL BEARING APPLICATIONS

Manufacturer Line Number	Inner Set	Outer Set	Inner (Cone/Cup)	Outer (Cone/Cup)	Timken	National	Stemco	SKF

**ROCKWELL-See ARVINMERITOR** (continued)

<b>150</b>									
TANDEM REAR AXLE - STD; THRU 1973 .....	Set402	-	582	42687	-	370030A	309-0961	42800	
	-	-	572	42620	-	-	-	-	
TANDEM REAR AXLE - FORD, GMC & IHC W/RA-315; THRU 1973 .....	Set411	Set408	47686	39590	-	370030A	309-0961	42800	
	-	-	47620	39520	-	-	-	-	
TANDEM REAR AXLE - STD; ALL 1974 ON ....	Set411	Set408	47686	39590	-	370030A	309-0961	42800	
	-	-	47620	39520	-	-	-	-	
<b>151</b>									
TANDEM REAR AXLE - STD; THRU 1973 .....	Set402	-	582	42687	TKR848	370024A	309-0915	38750	
	-	-	572	42620	-	-	-	-	
TANDEM REAR AXLE - BROCKWAY, CHEV, DODGE-1964 ON, FORD, GMC, & IHC; THRU 1973 .....	Set411	Set408	47686	39590	TKR848	370024A	309-0915	38750	
	-	-	47620	39520	-	-	-	-	
TANDEM REAR AXLE - STD; ALL 1974 ON ....	Set411	Set408	47686	39590	TKR848	370024A	309-0915	38750	
	-	-	47620	39520	-	-	-	-	
<b>152</b>									
PLANETARY REAR AXLES .....	-	-	67390	67391	-	-	-	-	
	-	-	67322	67322	-	-	-	-	
<b>153</b>									
PLANETARY REAR AXLES .....	-	-	67787	67787	-	-	-	-	
	-	-	67720	67720	-	-	-	-	
<b>154</b>									
PLANETARY REAR AXLES .....	-	-	M238849	M238849	-	-	-	-	
	-	-	M238810	M238810	-	-	-	-	
<b>155</b>									
PLANETARY REAR AXLES .....	-	-	48290	48290	-	-	-	-	
	-	-	48220	48220	-	-	-	-	
<b>156</b>									
PLANETARY REAR AXLES .....	-	-	67390	67391	-	-	-	-	
	-	-	67322	67322	-	-	-	-	
<b>157</b>									
PLANETARY REAR AXLES .....	-	-	67787	67787	-	-	-	-	
	-	-	67720	67720	-	-	-	-	
<b>158</b>									
TANDEM REAR AXLE .....	Set403	Set401	594A	580	TKR861	370003A	309-0973	47697	
	-	-	592A	572	-	-	-	-	
<b>159</b>									
TANDEM REAR AXLE - THRU 2-81 .....	Set404	-	598A	-	TKR861	370003A	309-0973	47697	
	-	-	592A	-	-	-	-	-	
TANDEM REAR AXLE - 3-81 ON .....	Set403	-	594A	-	TKR861	370003A	309-0973	47697	
	-	-	592A	-	-	-	-	-	
TANDEM REAR AXLE .....	-	Set401	-	580	TKR861	370003A	309-0973	47697	
	-	-	-	572	-	-	-	-	
<b>160</b>									
TANDEM REAR AXLE - THRU 2-81 .....	Set404	-	598A	-	-	370030A	309-0961	42800	
	-	-	592A	-	-	-	-	-	
TANDEM REAR AXLE - 3-81 ON .....	Set403	-	594A	-	-	370030A	309-0961	42800	
	-	-	592A	-	-	-	-	-	
TANDEM REAR AXLE .....	-	Set401	-	580	-	370030A	309-0961	42800	
	-	-	-	572	-	-	-	-	

Manufacturer Line Number	Inner Set	Outer Set	Inner (Cone/Cup)	Outer (Cone/Cup)	Timken	National	Stemco	SKF

**ROCKWELL-See ARVINMERITOR (continued)**

<b>161</b>								
TANDEM REAR AXLE - STD & AUTOCAR 9-79 ON ;THRU 2-81 .....	Set404	-	598A 592A	-	-	370030A	309-0961	42800
TANDEM REAR AXLE - STD & AUTOCAR 9-79 ON ;3-81 ON .....	Set403	-	594A 592A	-	-	370030A	309-0961	42800
TANDEM REAR AXLE - STD & AUTOCAR 9-79 ON .....	-	Set401	-	580 572	-	370030A	309-0961	42800
TANDEM REAR AXLE - AUTOCAR 11-74 THRU 8-79 .....	-	Set401	681A 672	580 572	-	370030A	309-0961	42800
TANDEM REAR AXLE - FORD THRU 3-76 & IHC W/RA-333/4 .....	-	-	598 592A	575 572	-	370030A	309-0961	42800
TANDEM REAR AXLE - FORD 4-76 ON .....	Set403	Set401	594A 592A	580 572	-	370030A	309-0961	42800

<b>162</b>								
TANDEM REAR AXLE - THRU 2-81 .....	Set404	-	598A 592A	-	-	370030A	309-0961	42800
TANDEM REAR AXLE - 3-81 ON .....	Set403	-	594A 592A	-	-	370030A	309-0961	42800
TANDEM REAR AXLE .....	-	Set401	-	580 572	-	370030A	309-0961	42800

<b>163</b>								
TANDEM REAR AXLE .....	Set403	Set401	594A 592A	580 572	TKR861	370003A	309-0973	47697

<b>164</b>								
TANDEM REAR AXLE - THRU 2-81 .....	Set404	-	598A 592A	-	TKR861	370003A	309-0973	47697
TANDEM REAR AXLE - 3-81 ON .....	Set403	-	594A 592A	-	TKR861	370003A	309-0973	47697
TANDEM REAR AXLE .....	-	Set401	-	580 572	TKR861	370003A	309-0973	47697

<b>165</b>								
TANDEM REAR AXLE - STD; THRU 2-81 .....	Set404	-	598A 592A	-	TKR861	370003A	309-0973	47697
TANDEM REAR AXLE - STD; 3-81 ON .....	Set403	-	594A 592A	-	TKR861	370003A	309-0973	47697
TANDEM REAR AXLE - STD .....	-	Set401	-	580 572	TKR861	370003A	309-0973	47697

<b>166</b>								
TANDEM REAR AXLE .....	Set403	Set401	594A 592A	580 572	TKR861	370003A	309-0973	47697

<b>167</b>								
TANDEM REAR AXLE .....	Set403	Set401	594A 592A	580 572	-	370120A	-	55177

<b>168</b>								
TANDEM REAR AXLE - THRU 2-81 .....	Set404	-	598A 592A	-	TKR861	370003A	309-0973	47697
TANDEM REAR AXLE - 3-81 ON .....	Set403	-	594A 592A	-	TKR861	370003A	309-0973	47697
TANDEM REAR AXLE .....	-	Set401	-	580 572	TKR861	370003A	309-0973	47697

HEAVY-DUTY WHEEL BEARING APPLICATIONS

Manufacturer Line Number	Inner Set	Outer Set	Inner (Cone/Cup)	Outer (Cone/Cup)	Timken	National	Stemco	SKF

**ROCKWELL-See ARVINMERITOR** (continued)

<b>169</b>								
TANDEM REAR AXLE - THRU 2-81 .....	Set404	-	598A	-	-	370030A	309-0961	42800
	-	-	592A	-	-	-	-	-
TANDEM REAR AXLE - 3-81 ON .....	Set403	-	594A	-	-	370030A	309-0961	42800
	-	-	592A	-	-	-	-	-
TANDEM REAR AXLE .....	-	Set401	-	580	-	370030A	309-0961	42800
	-	-	-	572	-	-	-	-
<b>170</b>								
TANDEM REAR AXLE - STD & AUTOCAR 9-79 ON ;THRU 2-81 .....	-	-	-	-	-	-	-	-
	Set404	-	598A	-	-	370006A	309-0970	47699
	-	-	592A	-	-	-	-	-
TANDEM REAR AXLE - STD & AUTOCAR 9-79 ON ;3-81 ON .....	-	-	-	-	-	-	-	-
	Set403	-	594A	-	-	370006A	309-0970	47699
	-	-	592A	-	-	-	-	-
TANDEM REAR AXLE - STD & AUTOCAR 9-79 ON .....	-	-	-	-	-	-	-	-
	-	Set401	-	580	-	370006A	309-0970	47699
	-	-	-	572	-	-	-	-
TANDEM REAR AXLE - AUTOCAR THRU 8-79 & WHITE-OPT 10-1-70 ON .....	-	-	-	-	-	-	-	-
	-	Set401	681A	580	-	370006A	309-0970	47699
	-	-	672	572	-	-	-	-
<b>171</b>								
TANDEM REAR AXLE - STD & AUTOCAR 9-79 ON ;THRU 2-81 .....	-	-	-	-	-	-	-	-
	Set404	-	598A	-	-	-	-	-
	-	-	592A	-	-	-	-	-
TANDEM REAR AXLE - STD & AUTOCAR 9-79 ON ;3-81 ON .....	-	-	-	-	-	-	-	-
	Set403	-	594A	-	-	-	-	-
	-	-	592A	-	-	-	-	-
TANDEM REAR AXLE - STD & AUTOCAR 9-79 ON .....	-	-	-	-	-	-	-	-
	-	Set401	-	580	-	-	-	-
	-	-	-	572	-	-	-	-
TANDEM REAR AXLE - AUTOCAR THRU 8-79 & WHITE-OPT 10-1-70 ON .....	-	-	-	-	-	-	-	-
	-	Set401	681A	580	-	-	-	-
	-	-	672	572	-	-	-	-
<b>172</b>								
TANDEM REAR AXLE - STD; THRU 2-81 .....	Set404	-	598A	-	-	-	-	-
	-	-	592A	-	-	-	-	-
TANDEM REAR AXLE - STD; 3-81 ON .....	Set403	-	594A	-	-	-	-	-
	-	-	592A	-	-	-	-	-
TANDEM REAR AXLE - STD .....	-	Set401	-	580	-	-	-	-
	-	-	-	572	-	-	-	-
<b>173</b>								
TANDEM REAR AXLE .....	Set403	Set401	594A	580	-	370120A	-	55177
	-	-	592A	572	-	-	-	-
<b>174</b>								
TANDEM REAR AXLE .....	-	-	782	749	-	370120A	-	55177
	-	-	772	742	-	-	-	-
<b>175</b>								
TANDEM REAR AXLE - STD .....	Set403	Set401	594A	580	-	370030A	309-0961	42800
	-	-	592A	572	-	-	-	-
TANDEM REAR AXLE - AUTOCAR & BROCKWAY 1-1-74 ON .....	-	-	-	-	-	-	-	-
	-	Set401	683XA	580	-	370030A	309-0961	42800
	-	-	672	572	-	-	-	-
<b>176</b>								
TANDEM REAR AXLE - STD .....	-	-	782	749	-	370120A	-	55177
	-	-	772	742	-	-	-	-

Manufacturer Line Number	Inner Set	Outer Set	Inner (Cone/Cup)	Outer (Cone/Cup)	Timken	National	Stemco	SKF

**ROCKWELL-See ARVINMERITOR (continued)**

<b>177</b>	TANDEM REAR AXLE - STD .....	-	-	782	749	-	-	-	-
		-	-	772	742	-	-	-	-
<b>178</b>	TANDEM REAR AXLE .....	-	-	760	749	-	370030A	309-0961	42800
		-	-	752	742	-	-	-	-
<b>179</b>	TANDEM REAR AXLE - STD .....	-	-	782	749	-	370120A	-	55177
		-	-	772	742	-	-	-	-
<b>180</b>	TANDEM REAR AXLE .....	-	-	782	6580	-	-	-	-
		-	-	772	6535	-	-	-	-
<b>181</b>	TANDEM REAR AXLE .....	-	-	581	575	TKR850	370036A	307-0713	40136
		-	-	572	572	-	-	-	-
<b>182</b>	TANDEM REAR AXLE .....	-	-	760	749	-	370004A	-	48884
		-	-	752	742	-	-	-	-
<b>183</b>	REAR AXLE - STD .....	-	-	782	749	-	370120A	-	55177
		-	-	772	742	-	-	-	-
<b>184</b>	REAR AXLE .....	-	-	782	749	-	-	-	-
		-	-	772	742	-	-	-	-
<b>185</b>	REAR AXLE .....	-	-	760	749	TKR861	370003A	309-0973	47697
		-	-	752	742	-	-	-	-
<b>186</b>	REAR AXLE .....	-	-	782	749	-	370120A	-	55177
		-	-	772	742	-	-	-	-
<b>187</b>	REAR AXLE .....	-	-	782	749	-	370120A	-	55177
		-	-	772	742	-	-	-	-
<b>188</b>	REAR AXLE .....	-	-	760	749	-	370004A	-	48884
		-	-	752	742	-	-	-	-
<b>189</b>	REAR AXLE .....	-	-	782	6580	-	-	-	-
		-	-	772	6535	-	-	-	-
<b>190</b>	REAR AXLE .....	-	-	782	6580	-	-	-	-
		-	-	772	6535	-	-	-	-
<b>191</b>	TRAILER AXLE .....	-	Set413	665A	HM212049	TKR853	370037A	307-0744	43752
		-	-	653	HM212011	-	-	-	-
<b>192</b>	TRAILER AXLE .....	Set414	Set413	HM218248	HM212049	TKR859	370025A	307-0743	46305
		-	-	HM218210	HM212011	-	-	-	-

HEAVY-DUTY WHEEL BEARING APPLICATIONS

Manufacturer Line Number	Inner Set	Outer Set	Inner (Cone/Cup)	Outer (Cone/Cup)	Timken	National	Stemco	SKF

**ROCKWELL-See ARVINMERITOR** (continued)

<b>193</b>	TRAILER AXLE .....	-	Set406	HM212044 HM212011	3782 3720	- -	- -	- -	- -
<b>194</b>	TRAILER AXLE .....	-	-	495AX 493	3984 3920	- -	370008A -	- -	39380 -
<b>195</b>	TRAILER AXLE .....	Set405	Set413	663 653	HM212049 HM212011	TKR850 -	370036A -	307-0713 -	40136 -
<b>196</b>	TRAILER AXLE .....	Set404	Set401	598A 592A	580 572	- -	- -	- -	- -
<b>197</b>	TRAILER AXLE .....	-	-	495AX 493	3984 3920	- -	370008A -	- -	39380 -
<b>198</b>	TRAILER AXLE .....	Set405	-	663 653	-	TKR850 -	370036A -	307-0713 -	40136 -
	TRAILER AXLE - Some Use 560/553X .....	-	Set413	-	HM212049 HM212011	TKR850 -	370036A -	307-0713 -	40136 -
<b>199</b>	TRAILER AXLE .....	Set405	Set413	663 653	HM212049 HM212011	TKR850 -	370036A -	307-0713 -	40136 -
<b>200</b>	TRAILER AXLE .....	-	Set413	665A 653	HM212049 HM212011	TKR853 -	370037A -	307-0744 -	43752 -
<b>201</b>	TRAILER AXLE .....	Set414	Set413	HM218248 HM218210	HM212049 HM212011	TKR859 -	370025A -	307-0743 -	46305 -
<b>202</b>	TRAILER AXLE .....	Set414	Set413	HM218248 HM218210	HM212049 HM212011	- -	- -	- -	- -
<b>203</b>	TRAILER AXLE .....	Set414	Set413	HM218248 HM218210	HM212049 HM212011	TKR850 -	370036A -	307-0713 -	40136 -
<b>204</b>	TRAILER AXLE .....	-	Set413	665A 653	HM212049 HM212011	TKR853 -	370037A -	307-0744 -	43752 -
<b>205</b>	TRAILER AXLE .....	Set403	Set401	594A 592A	580 572	- -	- -	- -	- -
<b>206</b>	TRAILER AXLE .....	Set414	Set413	HM218248 HM218210	HM212049 HM212011	TKR859 -	370025A -	307-0743 -	46305 -
<b>207</b>	TRAILER AXLE .....	Set415	Set415	HM518445 HM518410	HM518445 HM518410	TKR851 -	370065A -	307-0723 -	42623 -
<b>208</b>	TRAILER AXLE .....	Set414	Set413	HM218248 HM218210	HM212049 HM212011	TKR859 -	370025A -	307-0743 -	46305 -

Manufacturer Line Number	Inner Set	Outer Set	Inner (Cone/Cup)	Outer (Cone/Cup)	Timken	National	Stemco	SKF

**ROCKWELL-See ARVINMERITOR (continued)**

<b>209</b>	TRAILER AXLE .....	Set403 -	Set401 -	594A 592A	580 572	TKR861 -	370003A -	309-0973 -	47697 -
<b>210</b>	TRAILER AXLE .....	- -	- -	52401 52637	596 592A	- -	370004A -	- -	48884 -
<b>211</b>	TRAILER AXLE .....	- -	- -	786 772	HM617049 HM617010	- -	- -	- -	- -

**STANDARD FORGE Axle Model Index**

Model	Line No.	Model	Line No.	Model	Line No.	Model	Line No.
A-11 SERS. ....	1	A-19 SERS. ....	6	A-26 SERS. ....	11	A-65 SERS. ....	16
A-13 SERS. ....	2	A-20 SERS. ....	7	A-40 SERS. ....	12	S-700 SERS. ....	17
A-15 SERS. ....	3	A-21 SERS. ....	8	A-45 SERS. ....	13	S-900 SERS. ....	18
A-16 SERS. ....	4	A-22 SERS. ....	9	A-50 SERS. ....	14	T8.5 SERS. ....	19
A-17 SERS. ....	5	A-25 SERS. ....	10	A-60 SERS. ....	15	TA-16S-60 SERS. ....	20

Manufacturer Line Number	Inner Set	Outer Set	Inner (Cone/Cup)	Outer (Cone/Cup)	Timken	National	Stemco	SKF

**STANDARD FORGE**

<b>1</b>	TRAILER AXLE .....	- -	- -	560S 552A	419 414	- -	370029A -	- -	- -
<b>2</b>	TRAILER AXLE .....	Set425 -	- -	567 563	528 522	- -	370002A -	- -	35075 -
<b>3</b>	TRAILER AXLE .....	Set425 -	- -	567 563	528 522	- -	370002A -	- -	35075 -
<b>4</b>	TRAILER AXLE .....	Set401 -	Set413 -	580 572	HM212049 HM212011	- -	- -	- -	- -
<b>5</b>	TRAILER AXLE .....	Set405 -	- -	663 653	560 553X	TKR850 -	370036A -	307-0713 -	40136 -
<b>6</b>	TRAILER AXLE - Some Use 665A Cone .....	Set405 -	- -	663 653	- -	TKR850 -	370036A -	307-0713 -	40136 -
	TRAILER AXLE .....	- -	Set413 -	- -	HM212049 HM212011	TKR850 -	370036A -	307-0713 -	40136 -
<b>7</b>	TRAILER AXLE .....	- -	- -	749 742	643 632	- -	370107A -	- -	42624 -
	TRAILER AXLE - OPT .....	- -	- -	- -	643 633	- -	370107A -	- -	42624 -
<b>8</b>	TRAILER AXLE .....	- -	- -	749 742	643 632	- -	370107A -	- -	42624 -
	TRAILER AXLE - OPT .....	- -	- -	- -	643 633	- -	370107A -	- -	42624 -

HEAVY-DUTY WHEEL BEARING APPLICATIONS

Manufacturer Line Number	Inner Set	Outer Set	Inner (Cone/Cup)	Outer (Cone/Cup)	Timken	National	Stemco	SKF

**STANDARD FORGE** (continued)

<b>9</b>	TRAILER AXLE .....	Set414	Set413	HM218248 HM218210	HM212049 HM212011	TKR859 -	370025A -	307-0743 -	46305 -
<b>10</b>	TRAILER AXLE .....	-	-	760 752	749 742	- -	370192A -	- -	45162 -
<b>11</b>	TRAILER AXLE .....	-	-	759 752	740 742	- -	370192A -	- -	45162 -
<b>12</b>	TRAILER AXLE .....	-	-	780 772	6580 6521	- -	- -	- -	- -
	TRAILER AXLE - OPT .....	-	-	-	6580 6535	- -	- -	- -	- -
<b>13</b>	TRAILER AXLE .....	-	-	787 772	6580 6535	- -	- -	- -	- -
<b>14</b>	TRAILER AXLE .....	-	-	896 892	6580 6535	- -	- -	- -	- -
<b>15</b>	TRAILER AXLE .....	-	-	896 892	6580 6535	- -	- -	- -	- -
<b>16</b>	TRAILER AXLE .....	-	-	896 892	6580 6535	- -	- -	- -	- -
<b>17</b>	TRAILER AXLE .....	Set405	-	663 653	560 553X	TKR850 -	370036A -	307-0713 -	40136 -
<b>18</b>	TRAILER AXLE - Some Use 665A Cone .....	Set405	-	663 653	-	TKR850 -	370036A -	307-0713 -	40136 -
	TRAILER AXLE .....	-	Set413	-	HM212049 HM212011	TKR850 -	370036A -	307-0713 -	40136 -
<b>19</b>	TRAILER AXLE .....	-	-	28995 28920	25580 25523	- -	370010A -	- -	28820 -
<b>20</b>	TRAILER AXLE .....	Set401	-	580 572	560 553X	- -	- -	- -	- -

**VOLVO Axle Model Index**

Model	Line No.	Model	Line No.	Model	Line No.	Model	Line No.
F607 .....	1	F611 (chassis 2377) .....	3	F613 (chassis 6451) .....	8	N10 .....	12
F610 .....	1	F612 (chassis 6450) .....	5	F614 (chassis CH703) .....	9		
F6111 .....	4	F612 (chassis 6451) .....	6	F614 (chassis CH704) .....	10		
F611 (chassis 2376) .....	2	F613 (chassis 6450) .....	7	F7 .....	11		

Manufacturer Line Number	Inner Set	Outer Set	Inner (Cone/Cup)	Outer (Cone/Cup)				
					Timken	National	Stemco	SKF

**VOLVO**

<b>3</b>			JM207047					
	-	-	JM207010	-	-	-	-	-
<b>6</b>			JM207047					
	-	-	JM207010	-	-	-	-	-
<b>8</b>			JM207047					
	-	-	JM207010	-	-	-	-	-
<b>10</b>			JM207047					
	-	-	JM207010	-	-	-	-	-
<b>11</b>			JF7049A	39580				
DISC & SPOKE WHLS FA7.5 METRIC TONS .	-	-	JF7010	39520	-	-	-	-
	-	-			-	-	-	-
DISC WHLS FA6.5-METRIC TONS, BC286	-	-	6386	537	-	-	-	-
& SPOKE WHL	-	-	6320	532X	-	-	-	-
	-	-			-	-	-	-
DISC & SPOKE WHLS-4X2, 6X2 & 6X4	-	Set405	683	663	-	-	-	-
	-	-	672	653	-	-	-	-
<b>12</b>								
SPOKE WHL, DISC WHL FA6.5-METRIC	-	-	6386	537	-	-	-	-
TONS, FA5.5-METRIC TONS	-	-	6320	532X	-	-	-	-
	-	-			-	-	-	-
SPOKE WHL, DISC WHL FA6.5-METRIC	-	-			-	-	-	-
TONS, FA5.5-METRIC TONS ;SPOKE & DISC	-	Set405	683	663	-	-	-	-
	-	-	672	653	-	-	-	-

**WHITE GMC AUTOCAR Axle Model Index**

Model	Line No.	Model	Line No.	Model	Line No.	Model	Line No.
G	1	GG	1	TK	2		

Manufacturer Line Number	Inner Set	Outer Set	Inner (Cone/Cup)	Outer (Cone/Cup)				
					Timken	National	Stemco	SKF

**WHITE GMC AUTOCAR**

<b>1</b>			77375	77375				
REAR AXLE	-	-	77675	77675	-	-	-	-
<b>2</b>			749	749				
REAR AXLE	-	-	742	742	-	-	-	-

**WHITE GMC Axle Model Index**

Model	Line No.	Model	Line No.	Model	Line No.	Model	Line No.
114D	1	154C	24	F3W-125	8	F5W-140	16
115D	1	189C	25	F3W-140	9	F5W-80	17
116D	2	199C	25	F3W-1400	10	F6W-100	18
121D	2	240C	25	F3W-141	10	F6W-120	19
122D	2	89C	26	F3W-80	11	F6W-1200	20
124C	21	F3-100	4	F5-100	12	F6W-125	20
12D	3	F3-120	5	F5-120	13	F6W-1400	20
130C	21	F3-140	5	F5-140	13	F6W-141	20
133C	21	F3W-100	6	F5-80	14	TS-135	27
134C	22	F3W-120	7	F5W-100	15	TS-135L	27
143C	23	F3W-1200	8	F5W-120	16	TS-150	27

HEAVY-DUTY WHEEL BEARING APPLICATIONS

Manufacturer Line Number	Inner Set	Outer Set	Inner (Cone/Cup)	Outer (Cone/Cup)	Timken	National	Stemco	SKF

**WHITE GMC**

<b>1</b>	FRONT AXLE .....	-	-	539 532A	417 414A	-	370018A	-	32470
<b>2</b>	FRONT AXLE .....	Set413	Set406	HM212049 HM212011	3782 3720	-	370012A	-	36285
<b>3</b>	FRONT AXLE .....	-	-	6389 6320	537 532A	-	370015A	-	40040
<b>4</b>	FRONT AXLE .....	-	-	HM212046 HM212011	3583 3525	-	370012A	-	36285
<b>5</b>	FRONT AXLE .....	Set413	Set406	HM212049 HM212011	3782 3720	-	370012A	-	36285
<b>6</b>	FRONT AXLE .....	-	-	HM212046 HM212011	3583 3525	-	370012A	-	36285
<b>7</b>	FRONT AXLE .....	Set413	Set406	HM212049 HM212011	3782 3720	-	370012A	-	36285
<b>8</b>	FRONT AXLE .....	-	Set406	HM212049 HM212011	3782 3720	-	370012A	-	36285
<b>9</b>	FRONT AXLE .....	Set413	Set406	HM212049 HM212011	3782 3720	-	370012A	-	36285
<b>10</b>	FRONT AXLE .....	-	Set406	HM212049 HM212011	3782 3720	-	370012A	-	36285
<b>11</b>	FRONT AXLE .....	-	-	539 532A	417 414A	-	370018A	-	32470
<b>12</b>	FRONT AXLE .....	-	-	HM212046 HM212011	3583 3525	-	370012A	-	36285
<b>13</b>	FRONT AXLE .....	Set413	Set406	HM212049 HM212011	3782 3720	-	370012A	-	36285
<b>14</b>	FRONT AXLE .....	-	-	539 532A	417 414A	-	370018A	-	32470
<b>15</b>	FRONT AXLE .....	-	-	HM212046 HM212011	3583 3525	-	370012A	-	36285
<b>16</b>	FRONT AXLE .....	Set413	Set406	HM212049 HM212011	3782 3720	-	370012A	-	36285
<b>17</b>	FRONT AXLE .....	-	-	539 532A	417 414A	-	370018A	-	32470

Manufacturer Line Number	Inner Set	Outer Set	Inner (Cone/Cup)	Outer (Cone/Cup)	Timken	National	Stemco	SKF

**WHITE GMC (continued)**

<b>18</b>								
FRONT AXLE .....	-	-	HM212046	3583	-	370012A	-	36285
	-	-	HM212011	3525	-	-	-	-
<b>19</b>								
FRONT AXLE .....	Set413	Set406	HM212049	3782	-	370012A	-	36285
	-	-	HM212011	3720	-	-	-	-
<b>20</b>								
FRONT AXLE .....	-	Set406	HM212049	3782	-	370012A	-	36285
	-	-	HM212011	3720	-	-	-	-
<b>21</b>								
REAR AXLE .....	Set404	Set401	598A	580	TKR861	370003A	309-0973	47697
	-	-	592A	572	-	-	-	-
<b>22</b>								
REAR AXLE .....	-	Set401	681A	580	-	370006A	309-0970	47699
	-	-	672	572	-	-	-	-
<b>23</b>								
REAR AXLE .....	Set404	Set401	598A	580	TKR861	370003A	309-0973	47697
	-	-	592A	572	-	-	-	-
<b>24</b>								
REAR AXLE .....	-	-	77375	77375	-	-	-	-
	-	-	77675	77675	-	-	-	-
<b>25</b>								
REAR AXLE .....	-	Set401	681A	580	-	370006A	309-0970	47699
	-	-	672	572	-	-	-	-
<b>26</b>								
REAR AXLE .....	-	Set401	749	580	TKR854	370019A	309-0965	43860
	-	-	742	572	-	-	-	-
<b>27</b>								
REAR AXLE .....	Set404	Set401	598A	580	TKR861	370003A	309-0973	47697
	-	-	592A	572	-	-	-	-

# APPLICATIONS - SET-RIGHT™ HEAVY-DUTY HUB REBUILD KITS

## Rebuild Your Hubs – Get the Timken Advantage

### Kit Components: Features and Benefits

#### Quality Timken® MileMate® Bearings



- Original equipment used in heavy-duty, pre-adjusted wheel hub assemblies since 1995
- Engineered exclusively for pre-adjusted wheel hubs
- Precise half-stand tolerancing provides accurate setting every time
- Consistent and reliable internal geometry equals known performance
- Helps lengthen maintenance intervals
- Helps optimize bearing performance
- Timken “NP” part numbers
  - Proprietary design
  - Enhanced surfaces
  - More precise internal bearing geometry
  - Exceed industry standards
  - Rebuilding with NP parts helps ensure you get all the advantages that were originally engineered into the heavy-duty, pre-adjusted hub systems

#### Precision Machined Cone Spacer

- Designed for the rigorous demands of the heavy-duty wheel market
- Made from high-strength alloy
- Manufactured to precise tolerances
- Combined with Timken half-stand bearings and a special toleranced hub, the need for manual adjustment is eliminated



### Go With the Proven Leader

In order to make it easier and more convenient for you to rebuild hubs, Timken now offers Set-Right™ Heavy-Duty Hub Rebuild Kits incorporating two Timken MileMate sets – the original matched wheel bearing sets produced in North America - and a precision OE spacer.

In the mid-1970s, Timken engineers developed the Set-Right setting method to help optimize bearing performance. Then, in the mid-1990's, working with the leader in heavy-duty hub innovation, this pre-adjusted bearing technology was launched into the North American marketplace. The bearings used in these applications are known as half-stand bearings; they have half the stand tolerance (measurement tolerance) of that used in standard bearings. This means that the stand tolerance is twice as stringent (see diagram on backside). Timken has been supplying these bearings for the North American heavy-duty industry's most popular pre-adjusted wheel ends since 1995.

Using our specially toleranced bearings in conjunction with a precision OE machined spacer allows you to achieve the proper wheel bearing end-play, eliminating the need for manual bearing adjustment. The repeatability of the bearing setting range provides for optimum seal and bearing life. This consistency could help reduce fleet fuel costs.

We understand what the heavy-duty industry demands from their bearings and provide quality products that help to keep fleets operating more cost efficiently and cost effectively. In

fact, if you look inside your wheel-ends, the odds are in your favor that you'll find Timken bearings. Why not replace them with the original? Go with the proven leader.

Timken is where you turn for original matched wheel bearing sets and the assurance that your bearings are Set-Right.

**Set-Right Kits – The Right Choice**

- Enable faster and more reliable wheel-end builds; helps improve up-time
- Lower component counts; reduce inventory
- Help optimize seal performance and life
- Eliminate manual adjustment, one of the leading causes of wheel end issues

**Set-Right Heavy-Duty Hub Rebuild Kits and Components**

FFTC1 - FF Steer Kit			
Kit Contents	MileMate P/N	Component P/N	Qty
Inner half-stand NP Cone	SET427	NP899357	1
Inner half-stand NP Cup		NP026773	1
Outer half-stand NP Cone	SET428	NP874005	1
Outer half-stand NP Cup		NP435398	1
Spacer *		103592TKR	1

RDTC1 - R Drive Kit			
Kit Contents	MileMate P/N	Component P/N	Qty
Inner half-stand NP Cone	SET429	NP034946	1
Inner half-stand NP Cup		NP363298	1
Outer half-stand NP Cone	SET430	NP840302	1
Outer half-stand NP Cup		NP053874	1
Spacer *		103593TKR	1

TNTC1 - N Trailer Kit			
Kit Contents	MileMate P/N	Component P/N	Qty
Inner half-stand NP Cone	SET431	NP965350	1
Inner half-stand NP Cup		NP503727	1
Outer half-stand NP Cone	SET427	NP899357	1
Outer half-stand NP Cup		NP026773	1
Spacer *		104144TKR	1

TPTC1 - P Trailer Kit			
Kit Contents	MileMate P/N	Component P/N	Qty
Inner half-stand NP Cone	SET432	NP174964	1
Inner half-stand NP Cup		NP593561	1
Outer half-stand NP Cone	SET432	NP174964	1
Outer half-stand NP Cup		NP593561	1
Spacer *		104412TKR	1

\* Spacer not sold separately

**Half-Stand Bearing Description**

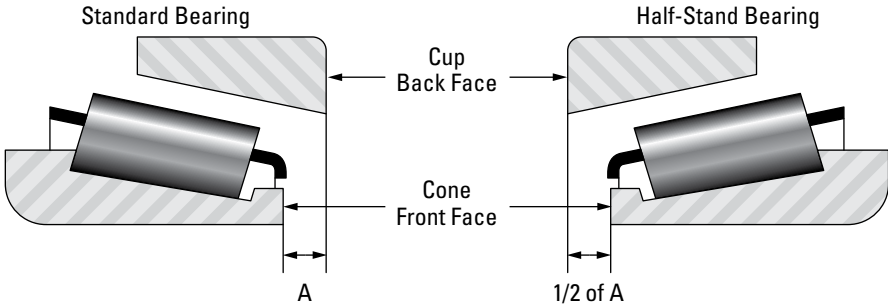

Assembled Stand Tolerance =  
 Measurement between the cone front face and cup back face  
 Standard bearing stand tolerance = A  
 Half-stand bearing tolerance = 1/2 of A

# APPLICATIONS - KIT DE REMONTAGE HAUTES PERFORMANCES TIMKEN SET-RIGHT™

## Reconditionnement des moyeux – Prenez une longueur d’avance avec Timken

### Composants du kit Caractéristiques et avantages

#### Roulements Timken® MileMate® de qualité



- Produits d’origine utilisés depuis 1995 dans les moyeux hautes performances préajustés
- Conçus exclusivement pour les moyeux préajustés
- Niveau de tolérance « half-stand » précis pour un réglage systématiquement correct
- Géométrie interne cohérente et fiable pour des performances garanties
- Intervalles de maintenance plus longs
- Optimisation des performances des roulements
- Références « NP » Timken
  - Conception exclusive
  - Surfaces améliorées
  - Géométrie interne des roulements plus précise
  - Qualité supérieure aux standards de l’industrie
  - Le remontage avec des pièces NP vous garantit un fonctionnement identique aux pièces d’origine intégrées dans les moyeux hautes performances préajustés

#### Usinage très précis de l’entretoise-cône

- Conçus pour le très exigeant marché des roues de poids lourds
- Réalisés en alliage haute résistance
- Fabriqués selon des tolérances précises
- Aucun réglage manuel lorsque associés à des roulements « half-stand » Timken et à un moyeu aux tolérances spéciales



#### Choisissez le leader mondial

Pour faciliter le remontage de vos moyeux, Timken vous propose les kits de remontage hautes performances Set-Right™ comprenant deux jeux MileMate – des roulements Timken fabriqués en Amérique du Nord – ainsi qu’une entretoise de précision d’origine.

Au milieu des années 1970, les ingénieurs Timken ont mis au point la méthode de réglage Set-Right permettant d’optimiser les performances des roulements. Ensuite, au milieu des années 1990, en collaboration avec le leader mondial des moyeux pour poids lourds, cette technologie de roulement préajusté a été commercialisée sur le marché nord-américain. Les roulements utilisés dans ce secteur sont appelés roulements « half-stand », car ils requièrent la moitié de la tolérance de fabrication des roulements standard. Autrement dit, la tolérance de fabrication est deux fois plus stricte (voir le schéma au verso). Timken fournit ces roulements pour les roues préajustées les plus utilisées sur les poids lourds en Amérique du Nord depuis 1995.

En combinant nos roulements à tolérance spéciale avec une entretoise d’origine à usinage haute précision, le jeu axial de roulement obtenu est optimal, sans avoir à effectuer de réglage manuel. La reproduction de l’opération de réglage garantit une durée de vie maximale tant pour le joint que pour le roulement. Cette cohérence permet de réduire la consommation en carburant des poids lourds.

Conscients du niveau d’exigence de l’industrie des poids lourds, nous lui fournissons des roulements de qualité

qui améliorent la rentabilité des véhicules. En fait, si vous regardez à l'intérieur de vos roues, il y a fort à parier qu'elles sont équipées de roulements Timken. Et si vous décidez de les remplacer par des roulements d'origine, mieux vaut vous adresser au leader mondial.

Pour des roulements d'origine ajustés de manière optimale, une seule référence : Timken.

**Kits Set-Right – Le bon choix**

- Des roues remontées plus rapidement pour des véhicules disponibles plus longtemps
- Moins de composantes donc moins d'inventaire
- Optimisation de la durée de vie et des performances des joints
- Aucun réglage manuel, l'une des principales causes des problèmes de roue

**Kits et composants de remontage hautes performances Timken Set-Right**

FFTC1 – Kit conduite FF			
Contenu du kit	Référence MileMate	Référence composant	Quantité
Cône NP « half-stand » intérieur	SET427	NP899357	1
Cuvette NP « half-stand » intérieure		NP026773	1
Cône NP « half-stand » extérieur	SET428	NP874005	1
Cuvette NP « half-stand » extérieure		NP435398	1
Entretoise*		103592TKR	1

RDTC1 – Kit motrice R			
Contenu du kit	Référence MileMate	Référence composant	Quantité
Cône NP « half-stand » intérieur	SET429	NP034946	1
Cuvette NP « half-stand » intérieure		NP363298	1
Cône NP « half-stand » extérieur	SET430	NP840302	1
Cuvette NP « half-stand » extérieure		NP053874	1
Entretoise*		103593TKR	1

TNTC1 – Kit remorque N			
Contenu du kit	Référence MileMate	Référence composant	Quantité
Cône NP « half-stand » intérieur	SET431	NP965350	1
Cuvette NP « half-stand » intérieure		NP503727	1
Cône NP « half-stand » extérieur	SET427	NP899357	1
Cuvette NP « half-stand » extérieure		NP026773	1
Entretoise*		104144TKR	1

TPTC1 – Kit remorque P			
Contenu du kit	Référence MileMate	Référence composant	Quantité
Cône NP « half-stand » intérieur	SET432	NP174964	1
Cuvette NP « half-stand » intérieure		NP593561	1
Cône NP « half-stand » extérieur	SET432	NP174964	1
Cuvette NP « half-stand » extérieure		NP593561	1
Entretoise*		104412TKR	1

\* Entretoise non vendue séparément

**Description d'un roulement « half-stand »**

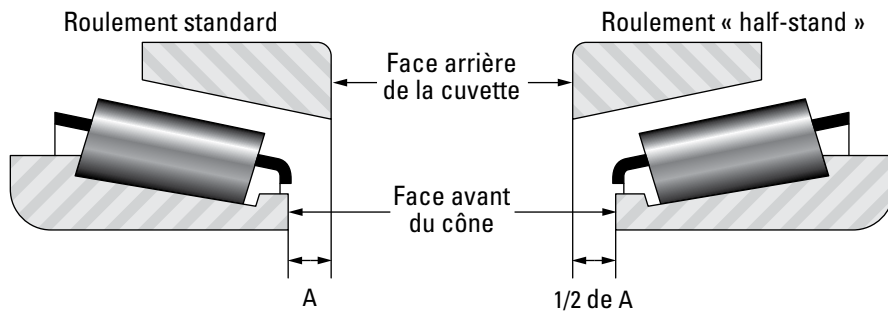

Tolérance de l'assemblage =  
 Mesure entre la face avant du cône et la face arrière de la cuvette  
 Tolérance de roulement standard = A  
 Tolérance de roulement «half-stand» = 1/2 de A

# APLICACIONES - KIT SET-RIGHT™ PARA REPARACIÓN DE MAZAS DE SERVICIO PESADO

Repare sus mazas - aproveche las ventajas de Timken

Componentes del kit Características y beneficios

Rodamientos Quality Timken® MileMate®



- Equipo original usado en ensambles preajustados de maza para servicio pesado, desde 1995
- Diseñado exclusivamente para mazas preajustadas
- La tolerancia precisa del ancho interno ofrece un ajuste más exacto
- La geometría interna uniforme y confiable
- Ayuda a prolongar los intervalos de mantenimiento
- Ayuda a mejorar el desempeño del rodamiento
- Números de parte Timken "NP"
  - Diseño patentado
  - Superficies mejoradas
  - Mayor precisión en la geometría interna del rodamiento
  - Supera los estándares de la industria
  - La reparación con partes NP le asegura la obtención de todas las ventajas que fueron diseñadas para equipo original en mazas preajustadas de servicio pesado

## Espaciador de conos maquinado a precisión

- Diseñados para las demandantes aplicaciones de las ruedas de equipos de servicio pesado
- Fabricados con una aleación de alta resistencia
- Fabricados para tolerancias precisas
- Combinados con rodamientos con tolerancias precisas y mazas especiales, se elimina la necesidad del ajuste manual de los rodamientos



## Comprobamos nuestro liderazgo

Para hacer más fácil y conveniente la reparación de las mazas, ahora Timken ofrece los kits Set-Right™ para reparación de mazas de servicio pesado, que incluyen dos juegos MileMate de Timken (juegos de rodamientos hechos en Norteamérica) y un espaciador de precisión de equipo original.

A mediados de los setenta, los ingenieros de Timken desarrollaron el método de ajuste Set-Right para optimizar el desempeño de los rodamientos. A mediados de los noventa, en conjunto con el líder en innovación de mazas de servicio pesado, se lanzó la tecnología de rodamientos preajustados al mercado norteamericano. Los rodamientos usados en estas aplicaciones se conocen como rodamientos con tolerancia de ancho reducida; tienen la mitad de la tolerancia del ancho de los rodamientos estándar. Esto significa que la tolerancia es doblemente estricta (ver diagrama en la parte posterior). Timken ha suministrado estos rodamientos a la industria norteamericana para los equipos más populares de servicio pesado desde 1995.

El uso de nuestros rodamientos de tolerancia especial, en conjunto con un espaciador maquinado a precisión de EO, le permite lograr el juego lateral axial apropiado para el rodamiento de la rueda, sin necesidad de realizar el ajuste manual del rodamiento. La consistencia del ajuste ofrece una optimizada vida útil tanto al retén como al rodamiento y ayuda a reducir costos en el combustible de las flotillas.

Comprendemos lo que la industria de servicio pesado exige en el desempeño de los rodamientos, por ello

ofrecemos productos de calidad que le ayuden a las flotillas a operar de forma más rentable y efectiva. De hecho, si observa al interior de sus ruedas, seguramente encontrará allí rodamientos Timken. ¿Por qué no reemplazarlos con los originales? Elija al líder comprobado.

Timken es adonde usted acude para obtener juegos de rodamientos para ruedas y la garantía de que sus rodamientos estarán bien ajustados porque son Set-Right.

**Kits Set-Right: la selección correcta**

- Permiten que el armado de los extremos de rueda sea más rápido y confiable; mayor tiempo productivo
- Menos componentes; reducen el inventario
- Optimizan el rendimiento y la vida útil de los retenes
- Eliminan el ajuste manual, una de las principales causas de los problemas en los extremos de las ruedas

**Kit Set-Right™ y componentes para reparación de mazas de servicio pesado**

FFTC1 - FF Kit para dirección			
Contenido del kit	N/P MileMate™	N/P de componentes	Cantidad
Cono interior NP de tolerancia especial	SET427	NP899357	1
Taza interior NP de tolerancia especial		NP026773	1
Cono exterior NP de tolerancia especial	SET428	NP874005	1
Taza exterior NP de tolerancia especial		NP435398	1
Espaciador *		103592TKR	1

RDTC1 - R Kit para transmisión			
Contenido del kit	N/P MileMate™	N/P de componentes	Cantidad
Cono interior NP de tolerancia especial	SET429	NP034946	1
Taza interior NP de tolerancia especial		NP363298	1
Cono exterior NP de tolerancia especial	SET430	NP840302	1
Taza exterior NP de tolerancia especial		NP053874	1
Espaciador *		103593TKR	1

TNTC1 - N Kit para remolque			
Contenido del kit	N/P MileMate™	N/P de componentes	Cantidad
Cono interior NP de tolerancia especial	SET431	NP965350	1
Taza interior NP de tolerancia especial		NP503727	1
Cono exterior NP de tolerancia especial	SET427	NP899357	1
Taza exterior NP de tolerancia especial		NP026773	1
Espaciador *		104144TKR	1

TPTC1 - P Kit para remolque			
Contenido del kit	N/P MileMate™	N/P de componentes	Cantidad
Cono interior NP de tolerancia especial	SET432	NP174964	1
Taza interior NP de tolerancia especial		NP593561	1
Cono exterior NP de tolerancia especial	SET432	NP174964	1
Taza exterior NP de tolerancia especial		NP593561	1
Espaciador *		104412TKR	1

\* El espaciador no se vende por separado

**Descripción del rodamiento de tolerancia de ancho especial**

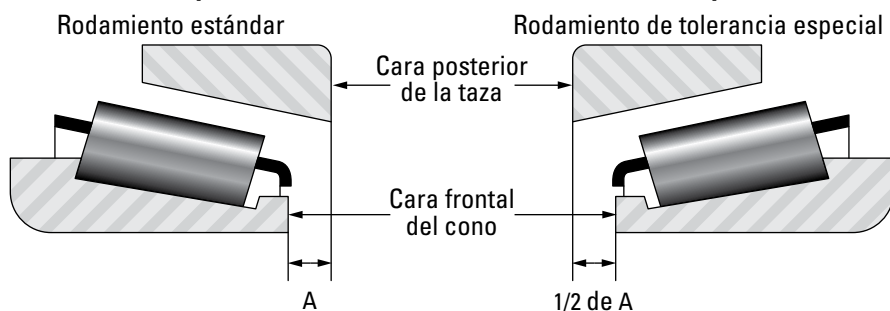

Tolerancia de ancho ensamblado =  
 Medición entre la cara frontal del cono y la cara posterior de la taza  
 Tolerancia estándar de ancho ensamblado = A  
 Tolerancia especial de ancho del rodamiento ensamblado = 1/2 de A

**HEAVY-DUTY BEARING GUIDE TOOLS**

<b>Axle</b>	<b>Bearing Cone No.</b>	<b>Bearing Centering Guide No.</b>	<b>Possible Oil Bath Seal Part No.</b>
D	495AX	BCT8	848, 849
S	557A	BCT3	847
T	575	BCT8	850
T or D	580	BCT10	850, 856
D	582	BCT10	856
T	593	BCT12	851
D	594	BCT15	858, 861
D	594A	BCT15	858, 860, 861
D	595	BCT10	854, 861
D	598	BCT14	854, 861
D	598A	BCT14	849, 854, 858, 860, 861
S	641	BCT06	855, 857
T or D	663	BCT10	850, 852, 853
T or D	665	BCT11	852, 853
D	759	BCT12	858
D	5760	BCT08	849
D	33287	BCT07	848
S	39581	BCT02	847
D	47678	BCT08	849
D	47686	BCT10	848, 849
S	HM212044	BCT03	847
S	HM212047	BCT04	847
S	HM212049	BCT06	847, 855
T	HM218248	BCT13	859
D	HM516449	BCT10	852
T	HM518445	BCT12	851
S	H715345	BCT16	855, 857
S	6461A	BCT08	863

## INTERCHANGE - GREASE SEALS TO OIL BATH SEALS

Grease Seals to Oil Bath Seals		Oil Bath Seals to Grease Seals	
Seal Number	National Number	National Number	Seal Number
2674	370054A	370001A	6638S
5473	370004A	370002A	9339S
5481	370003A	370003A	5481
5495	370006A	370004A	5473
6270	370008A	370006A	5495
6584S	370018A	370007A	7866S
6635S	370030A	370008A	6270
6638S	370001A	370009A	417506
7866S	370007A	370010A	417134
8872	370182A	370011A	416125
8976S	370145A	370014A	417172
9128S	370106A	370015A	416130
9339S	370002A	370018A	6584S
9864S	370150A	370019A	415060
415058	370031A	370020A	455209
415060	370019A	370021A	455062
415371	370022A	370022A	415371
416125	370011A	370024A	417505
416130	370015A	370025A	455211
416297	370046A	370028A	455070
417134	370010A	370029A	455022
417172	370014A	370030A	6635S
417505	370024A	370031A	415058
417506	370009A	370046A	416297
417530	370124A	370047A	455858
417531	370131A	370054A	2674
455022	370029A	370066A	455513
455062	370021A	370106A	9128S
455070	370028A	370124A	417530
455200	370178A	370131A	417531
455209	370020A	370145A	8976S
455211	370025A	370150A	9864S
455513	370066A	370165A	455958
455858	370047A	370178A	455200
455958	370165A	370182A	8872

# HEAVY-DUTY WHEEL SEAL INTERCHANGE LIST

Axle	Seal	Adapter Plate	Bearing Centering Guide	SKF Scotseal	SKF Scotseal Plus	SKF Scotseal Plus XL	FM National	FM National 5-Star	Stemco Grit Guard	Stemco Guardian	Stemco Voyager	Stemco Discover
Steer	TKR847*	847T	BCT6	35066	35059	35058	370001A	380001A	382-8036	308-0836	383-0136	383-0236
Drive	TKR848	848T	BCT10	38750	38748		370024A		392-9099	309-0915	393-0115	
Drive	TKR849	849T	BCT10	38780	38779	38776	370023A	380023A	392-9099	309-0912	393-0112	393-0212
Trailer	TKR850	850T	BCT10	40136	40133	40129	370036A	380036A	372-7098	307-0713	373-0113	373-0213
Trailer	TKR851*	851T	BCT12	42623	42622	42627	370065A 376590A	380065A	372-7099	307-0723	373-0123	373-0223
Drive	TKR852	852T	BCT10	42672	42671	42673	370031A	380031A	392-9130	309-0904	393-0104	393-0204
Trailer	TKR853	853T	BCT11	43752	43753	43754	370037A		372-7095	307-0744	373-0144	
Drive	TKR854	854T	BCT14	43860	43861		370019A		392-9096	309-0965		
Steer	TKR855	855T	BCT6	44922	44919	44916	370124A		382-8053	308-0853	383-0153	
Drive	TKR856	856T	BCT10	45099	45097	45093	370022A	380022A	392-9094	309-0903	393-0103	393-0203
Steer	TKR857	857T	BCT16	45103	45102	45095	370131A	380131A	382-8056	308-0856	383-0156	
Drive	TKR858	858T	BCT15	45160	45158	45157	370021A		392-9088	309-0964		
Trailer	TKR859*	859T	BCT13	46305	46304	46300	370025A	380025A	372-7097	307-0743	373-0143	373-0243
Drive	TKR860	860T	BCT14	48000	48001	48002	370005A		392-9081	309-0960		
Drive	TKR861*	861T	BCT15	47697	47695	47692	370003A	380003A	392-9131	309-0973	393-0173	393-0273
Steer	TKR863	863T	BCT8	43764	43763	43761	370048A	380048A	382-8064	308-0864	383-0164	383-0264

\* PH Wheel Seal

# DRIVELINE CENTER SUPPORT BEARINGS

**Interchangeability, Quality, Durability,  
Decreased Costs**

## Driveline Center Support Bearings For:

- Light duty pick-ups
- Light duty vans
- Mid-size trucks
- School buses
- Heavy duty highway vehicles



Now you can get Driveline Center Support Bearings through The Timken Company – interchangeable with all major truck applications.

Cross Reference						
Timken Part Number	DT Components Part Number	Dana-Spicer Part Number	Federal Mogul Part Number	Meritor Part Number	NEAPCO Part Number	SKF Part Number
HB206FF	HB210527-X	210527-X	HB206-FF	CB210527-X	210527-X	HB206-FF
HB88107B	HB210088-1X	210088-1X	HB88107-B	CB210088-1X	21008-1X	HB88107-B
HB88107C	HB210090-1X	210090-1X	HB88107-C	CB210090-1X	210090-1X	HB88107-C
HB88107D	HB210367-1X	210367-1X	HB88107-D	CB210367-1X	210367-1X	HB88107-D
HB88107E	HB210370-1X	210370-1X	HB88107-E	CB210370-1X	210370-1X	HB88107-E
HB88508AB	HB210866-1X	210866-1X	HB88508-AB	CB210866-1X	210866-1X	HB88508-AB
HB88508B	HB210433-1X	210433-1X	HB88508-B	CB210433-1X	210433-1X	HB88508-B
HB88508C	HB210140-1X	210140-1X	HB88508-C	CB210140-1X	210140-1X	HB88508-C
HB88508D	HB210144-1X	210144-1X	HB88508-D	CB210144-1X	210144-1X	HB88508-D
HB88508E	HB210391-1X	210391-1X	HB88508-E	CB210391-1X	210391-1X	HB88508-E
HB88509A	HB210084-2X	210084-2X	HM88509-A	CB210084-2X	210084-2X	HB88509-A
HB88509C	HB210207-1X	210207-1X	HB88509-C	CB210207-1X	210207-1X	HB88509-C
HB88510	HB210121-1X	210121-1X	HB88510	CB210121-1X	210121-1X	HB88510
HB88510S	HB210881-1X	210881-1X	HB88510-S	CB210881-1X	210881-1X	HB88510-S
HB88512AHD	HB210661-1X	210661-1X	HB88512-AHD	CB210661-1X	210661-1X	HB88512-A
HB88512ASHD	HB210875-1X	210875-1X	HB88512-AS	CB210875-1X	210875-1X	HB88512-AS

## MILEMATE®

### ONE SIMPLE GOAL: Keep Your Trucks Up and Moving

Timken® MileMate® sets – the original matched wheel bearing sets – are designed to keep your trucks up and moving. Our 44 matched cup and cone sets are built for superior results and less downtime. When you use the original MileMate sets from Timken, you know you're getting bearing sets specifically designed for your application that meet or exceed the original equipment manufacturer's specifications. This includes the ConMet® PreSet® and Spicer® LMS™, as well as the new wide single tire applications.



#### Features

- Made from quality Timken certified steel
- Perfectly matched sets for correct installation every time
- Original equipment technology

#### Benefits

- Matched sets mean less inventory and the bearing parts in one box to perform the job
- Lengthens maintenance intervals
- Optimizes bearing performance
- Allows bearings to carry evenly distributed loads
- Original equipment on ConMet PreSet and Spicer LMS enhances performance

### Timken Proprietary “NP” Part Numbers

Meeting the growing original and aftermarket performance demands.

#### Features

- Enhanced surfaces
- Proprietary Timken design
- More precise internal bearing geometry
- Exceed industry standards

#### Benefits

- Designed to provide longer life and reliability
- Many heavy-duty, pre-adjusted hubs are serviceable such as ConMet PreSet and Spicer LMS
- Rebuilding with Timken proprietary parts ensures you get all the advantages that were originally engineered into the heavy-duty, pre-adjusted hub systems
- Specifically designed to handle the 2” outset loads of the Michelin® X One™ and Bridgestone® Greatec™ wide single tires

Timken Set Number	Timken PartNumber	PopularManufacturers
Set 401	580, 572	ArvinMeritor / Dana / IHC / Mack / WhiteGMC
Set 402	582, 572	ArvinMeritor / Dana / Mack
Set 403	594A, 592A	ArvinMeritor / Dana / IHC
Set 404	598A, 592A	ArvinMeritor / Dana / Mack / WhiteGMC
Set 405	663, 653	ArvinMeritor / Clark / Dana / IHC / Mack / Standard / Volvo
Set 406	3782, 3720	ArvinMeritor / Dana / Ford / IHC / WhiteGMC
Set 407	28682, 28622	Dana / IHC
Set 408	39590, 39520	ArvinMeritor / Dana / IHC
Set 409	45280, 45220	Mack
Set 410	45284, 45220	ArvinMeritor / Dodge / Ford / GMC
Set 411	47686, 47620	ArvinMeritor / Dana / FWD / IHC
Set 412	HM212047, HM212011	ArvinMeritor / Dodge / Ford / GMC / Isuzu
Set 413	HM212049, HM212011	ArvinMeritor / Clark / Dana / Fruehauf / Hendrickson / IHC/IMT / Mack / Standard / WhiteGMC
Set 414	HM218248, HM218210	ArvinMeritor / Dana / Hendrickson / IMT / Kay-Brunner / Standard
Set 415	HM518445, HM518410	ArvinMeritor / Dana / Fruehauf / Hendrickson / MIT
Set 416	45291, 45220	ArvinMeritor / Dana
Set 417	47890, 47820	ArvinMeritor / IHC / Oshkosh / Standard
Set 418	H715334, H715311	ArvinMeritor / Oshkosh
Set 419	H715343, H715311	ArvinMeritor / IHC / Oshkosh
Set 420	H715345, H715311	ArvinMeritor / IHC / Mack / WhiteGMC
Set 421	HM516449A, HM516410	Mack
Set 422	HM516449C, HM516410	Mack
Set 423	6461A, 6420	ArvinMeritor / Dana / Dodge / Ford / Mack
Set 424	555-S, 552A	ArvinMeritor / Dana / Dodge / Ford / IHC / Mack
Set 425	567, 563	ArvinMeritor / Dana / Dodge / Ford / IHC / Iveco / Mack / Oshkosh / Standard
Set 426	47679, 47620	Mack
Set 427*	NP899357, NP026773	ConMet PreSet Steer / N Trailer
Set 428*	NP874005, NP435398	ConMet PreSet Steer
Set 429*	NP034946, NP363298	ConMet PreSet Drive
Set 430*	NP840302, NP053874	ConMet PreSet Drive
Set 431*	NP965350, NP503727	ConMet PreSet N Trailer
Set 432*	NP174964, NP593561	ConMet PreSet P Trailer
Set 433*	NP431952, NP378092	Dana LMS Steer / N Trailer
Set 434*	NP555065, NP720703	Dana LMS Steer
Set 435*	NP568900, NP107783	Dana LMS Drive
Set 436*	NP577914, NP975161	Dana LMS Drive
Set 437*	NP022333, NP250023	Dana LMS N Trailer
Set 438*	NP417549, NP156827	Dana LMS P Trailer
Set 439	HM212049X, HM212011	Volvo Steer
Set 440*	NP454049, NP454011	ArvinMeritor / Dana / Hendrickson / IMT
Set 441*	NP454248, NP454210	ArvinMeritor / Dana / Hendrickson / IMT
Set 442*	NP454580, NP454572	ArvinMeritor / Dana / Hendrickson / IMT
Set 443*	NP454594, NP454592	ArvinMeritor / Dana / Hendrickson / IMT
Set 444*	NP454445, NP454410	ArvinMeritor / Dana / Hendrickson / IMT



\* Proprietary Part Numbers

## MILEMATE®: FRENCH CANADIAN

### UN OBJECTIF SIMPLE : Maintenir vos camions en bon état de marche

Les ensembles de roulements de roues assortis originaux Timken® MileMate® sont conçus pour maintenir vos camions en bon état de marche. Nos 44 ensembles de cuvettes et de cônes assortis vous offrent des performances exceptionnelles et réduisent les temps d'arrêts. Les ensembles de roulements MileMate de Timken sont spécifiquement conçus pour vos applications et respectent, ou même dépassent, les spécifications du fabricant d'équipement. Cela couvre les moyeux ConMet® PreSet® et Spicer® LMS™, ainsi que les nouveaux roulements pour pneus uniques à bande large.



#### Caractéristiques

- Fabriqués en acier certifié Timken de qualité
- Les ensembles sont parfaitement assortis pour être toujours correctement installés
- Technologie d'équipement originale

#### Avantages

- Les roulements assortis sont fournis dans le même emballage et vous permettent de réduire vos inventaires
- Intervalles de maintenance moins fréquentes
- Optimisation de la performance des roulements
- Les roulements peuvent supporter des charges mieux réparties
- L'équipement d'origine des ensembles ConMet PreSet et Spicer LMS améliore la performance

### Numéros de pièces « NP » exclusifs de Timken

Pour satisfaire les besoins croissants en performance des marchés d'origine et secondaires

#### Caractéristiques

- Surfaces améliorées
- Conception exclusive de Timken
- Une géométrie de roulement interne plus précise
- Dépassent les normes de l'industrie

#### Avantages

- Conçus pour une plus grande fiabilité et durée de vie
- De nombreux moyeux industriels pré réglés, tels que ConMet PreSet et Spicer LMS, peuvent être réparés
- En rebâtissant avec des pièces exclusives Timken, vous profitez des avantages d'origine des systèmes de moyeux industriels pré réglés
- Conçus spécifiquement pour permettre un déport externe de 2 po des pneus à bande large Michelin® X One™ et Bridgestone® Greatec™

Timken Set Number	Timken PartNumber	PopularManufacturers
Set 401	580, 572	ArvinMeritor / Dana / IHC / Mack / WhiteGMC
Set 402	582, 572	ArvinMeritor / Dana / Mack
Set 403	594A, 592A	ArvinMeritor / Dana / IHC
Set 404	598A, 592A	ArvinMeritor / Dana / Mack / WhiteGMC
Set 405	663, 653	ArvinMeritor / Clark / Dana / IHC / Mack / Standard / Volvo
Set 406	3782, 3720	ArvinMeritor / Dana / Ford / IHC / WhiteGMC
Set 407	28682, 28622	Dana / IHC
Set 408	39590, 39520	ArvinMeritor / Dana / IHC
Set 409	45280, 45220	Mack
Set 410	45284, 45220	ArvinMeritor / Dodge / Ford / GMC
Set 411	47686, 47620	ArvinMeritor / Dana / FWD / IHC
Set 412	HM212047, HM212011	ArvinMeritor / Dodge / Ford / GMC / Isuzu
Set 413	HM212049, HM212011	ArvinMeritor / Clark / Dana / Fruehauf / Hendrickson / IHC/IMT / Mack / Standard / WhiteGMC
Set 414	HM218248, HM218210	ArvinMeritor / Dana / Hendrickson / IMT / Kay-Brunner / Standard
Set 415	HM518445, HM518410	ArvinMeritor / Dana / Fruehauf / Hendrickson / MIT
Set 416	45291, 45220	ArvinMeritor / Dana
Set 417	47890, 47820	ArvinMeritor / IHC / Oshkosh / Standard
Set 418	H715334, H715311	ArvinMeritor / Oshkosh
Set 419	H715343, H715311	ArvinMeritor / IHC / Oshkosh
Set 420	H715345, H715311	ArvinMeritor / IHC / Mack / WhiteGMC
Set 421	HM516449A, HM516410	Mack
Set 422	HM516449C, HM516410	Mack
Set 423	6461A, 6420	ArvinMeritor / Dana / Dodge / Ford / Mack
Set 424	555-S, 552A	ArvinMeritor / Dana / Dodge / Ford / IHC / Mack
Set 425	567, 563	ArvinMeritor / Dana / Dodge / Ford / IHC / Iveco / Mack / Oshkosh / Standard
Set 426	47679, 47620	Mack
Set 427*	NP899357, NP026773	ConMet PreSet Steer / N Trailer
Set 428*	NP874005, NP435398	ConMet PreSet Steer
Set 429*	NP034946, NP363298	ConMet PreSet Drive
Set 430*	NP840302, NP053874	ConMet PreSet Drive
Set 431*	NP965350, NP503727	ConMet PreSet N Trailer
Set 432*	NP174964, NP593561	ConMet PreSet P Trailer
Set 433*	NP431952, NP378092	Dana LMS Steer / N Trailer
Set 434*	NP555065, NP720703	Dana LMS Steer
Set 435*	NP568900, NP107783	Dana LMS Drive
Set 436*	NP577914, NP975161	Dana LMS Drive
Set 437*	NP022333, NP250023	Dana LMS N Trailer
Set 438*	NP417549, NP156827	Dana LMS P Trailer
Set 439	HM212049X, HM212011	Volvo Steer
Set 440*	NP454049, NP454011	ArvinMeritor / Dana / Hendrickson / IMT
Set 441*	NP454248, NP454210	ArvinMeritor / Dana / Hendrickson / IMT
Set 442*	NP454580, NP454572	ArvinMeritor / Dana / Hendrickson / IMT
Set 443*	NP454594, NP454592	ArvinMeritor / Dana / Hendrickson / IMT
Set 444*	NP454445, NP454410	ArvinMeritor / Dana / Hendrickson / IMT



\* Numéros de pièces exclusifs

## MILEMATE®: SPANISH

### UNA META SIMPLE: Mantener a sus camiones en movimiento

Los sets Timken® MileMate® – conjuntos de rodamientos para ruedas con especificaciones de Equipo Original – están diseñados para mantener a sus camiones en movimiento. Nuestros 44 sets de cono y taza, están diseñados para ofrecer resultados superiores y menores tiempos muertos. Cuando usted utiliza los sets originales MileMate de Timken, sabe que está obteniendo conjuntos de rodamientos específicamente diseñados para sus aplicaciones, y que cumplen o exceden las especificaciones del fabricante de equipo original. Entre éstas, se incluyen aquellas para las mazas ConMet® PreSet® y Spicer® LMS™, así como las nuevas aplicaciones de neumáticos anchos.



#### Características

- Fabricados con acero de calidad certificado por Timken
- Conjuntos perfectamente emparejados para obtener siempre una instalación correcta
- Tecnología de Equipo Original

#### Beneficios

- Los sets favorecen un menor inventario ya que incluyen ambas partes en un mismo empaque
- Prolongan el intervalo entre mantenimientos
- Optimizan el rendimiento de los rodamientos
- Permiten al rodamiento la distribución uniforme de la carga
- Aumentan el rendimiento de equipos originales con ConMet PreSet y Spicer LMS

#### Números de parte “NP” exclusivos de Timken

Cumpliendo con las exigencias de desempeño de Equipo Original y del mercado de repuesto.

#### Características

- Superficies mejoradas
- Diseño exclusivo de Timken
- Geometría interna del rodamiento más precisa
- Superan los estándares de la industria

#### Beneficios

- Diseñados para ofrecer confiabilidad y mayor vida útil
- Muchas de las mazas pre ajustadas para servicio pesado ConMet PreSet y Spicer LMS son susceptibles de mantenimiento
- Las reparaciones con piezas originales Timken aseguran que obtenga todas las ventajas que ofrecen los sistemas de mazas pre ajustadas para servicio pesado con ingeniería de Equipo Original
- Específicamente diseñados para manejar las cargas con 2” fuera de su centro, de los neumáticos anchos Michelin® X One™ y Bridgestone® Greatec™

Timken Set Number	Timken PartNumber	PopularManufacturers
Set 401	580, 572	ArvinMeritor / Dana / IHC / Mack / WhiteGMC
Set 402	582, 572	ArvinMeritor / Dana / Mack
Set 403	594A, 592A	ArvinMeritor / Dana / IHC
Set 404	598A, 592A	ArvinMeritor / Dana / Mack / WhiteGMC
Set 405	663, 653	ArvinMeritor / Clark / Dana / IHC / Mack / Standard / Volvo
Set 406	3782, 3720	ArvinMeritor / Dana / Ford / IHC / WhiteGMC
Set 407	28682, 28622	Dana / IHC
Set 408	39590, 39520	ArvinMeritor / Dana / IHC
Set 409	45280, 45220	Mack
Set 410	45284, 45220	ArvinMeritor / Dodge / Ford / GMC
Set 411	47686, 47620	ArvinMeritor / Dana / FWD / IHC
Set 412	HM212047, HM212011	ArvinMeritor / Dodge / Ford / GMC / Isuzu
Set 413	HM212049, HM212011	ArvinMeritor / Clark / Dana / Fruehauf / Hendrickson / IHC/IMT / Mack / Standard / WhiteGMC
Set 414	HM218248, HM218210	ArvinMeritor / Dana / Hendrickson / IMT / Kay-Brunner / Standard
Set 415	HM518445, HM518410	ArvinMeritor / Dana / Fruehauf / Hendrickson / MIT
Set 416	45291, 45220	ArvinMeritor / Dana
Set 417	47890, 47820	ArvinMeritor / IHC / Oshkosh / Standard
Set 418	H715334, H715311	ArvinMeritor / Oshkosh
Set 419	H715343, H715311	ArvinMeritor / IHC / Oshkosh
Set 420	H715345, H715311	ArvinMeritor / IHC / Mack / WhiteGMC
Set 421	HM516449A, HM516410	Mack
Set 422	HM516449C, HM516410	Mack
Set 423	6461A, 6420	ArvinMeritor / Dana / Dodge / Ford / Mack
Set 424	555-S, 552A	ArvinMeritor / Dana / Dodge / Ford / IHC / Mack
Set 425	567, 563	ArvinMeritor / Dana / Dodge / Ford / IHC / Iveco / Mack / Oshkosh / Standard
Set 426	47679, 47620	Mack
Set 427*	NP899357, NP026773	ConMet PreSet Steer / N Trailer
Set 428*	NP874005, NP435398	ConMet PreSet Steer
Set 429*	NP034946, NP363298	ConMet PreSet Drive
Set 430*	NP840302, NP053874	ConMet PreSet Drive
Set 431*	NP965350, NP503727	ConMet PreSet N Trailer
Set 432*	NP174964, NP593561	ConMet PreSet P Trailer
Set 433*	NP431952, NP378092	Dana LMS Steer / N Trailer
Set 434*	NP555065, NP720703	Dana LMS Steer
Set 435*	NP568900, NP107783	Dana LMS Drive
Set 436*	NP577914, NP975161	Dana LMS Drive
Set 437*	NP022333, NP250023	Dana LMS N Trailer
Set 438*	NP417549, NP156827	Dana LMS P Trailer
Set 439	HM212049X, HM212011	Volvo Steer
Set 440*	NP454049, NP454011	ArvinMeritor / Dana / Hendrickson / IMT
Set 441*	NP454248, NP454210	ArvinMeritor / Dana / Hendrickson / IMT
Set 442*	NP454580, NP454572	ArvinMeritor / Dana / Hendrickson / IMT
Set 443*	NP454594, NP454592	ArvinMeritor / Dana / Hendrickson / IMT
Set 444*	NP454445, NP454410	ArvinMeritor / Dana / Hendrickson / IMT



\* Números de parte exclusivos de Timken

## TIMKEN® 454-SERIES™ WHEEL BEARINGS FOR COMMERCIAL VEHICLES

### Bearings for duals and wide singles

- Specially designed to handle the 2" outset loads
- Allows consistency within fleets
- Provides flexibility of wheel arrangements

### Compatible with industry standard components

- Use with popular axle and hub designs
- Can retrofit into existing equipment

### Designed to improve bearing life

- Highly engineered internal raceway profiles for optimal stress distribution
- Proprietary enhanced surface finishes

At Timken, we recognize the need of commercial vehicle customers to conserve fuel, carry greater loads, standardize components and maximize uptime. These are

	Cone	Cup	MileMate® Set
N Trailer Outer	NP454049	NP454011	Set 440
N Trailer Inner	NP454248	NP454210	Set 441
R Drive Outer	NP454580	NP454572	Set 442
R Drive Inner	NP454594	NP454592	Set 443
P Trailer Inner & Outer	NP454445	NP454410	Set 444

See [www.timken.com/454wheelbearing](http://www.timken.com/454wheelbearing) for Limited Warranty information.

the driving factors behind the new Timken 454-Series™ bearings. The 454-Series bearings are geared towards helping your fleet operate more efficiently and cost effectively.

With over 100-years delivering excellence to the heavy truck industry, Timken's 454-Series continues the legacy by delivering tomorrow's high-performance wheel-end technology today.

For additional information, contact your Timken sales representative or our dedicated team of automotive and heavy-duty customer service representatives at: phone (866) 9-TIMKEN (984-6536), or fax (877) TIMKEN-9 (846-5369).

*Special race profiles and enhanced surface finish for optimal stress distribution.*

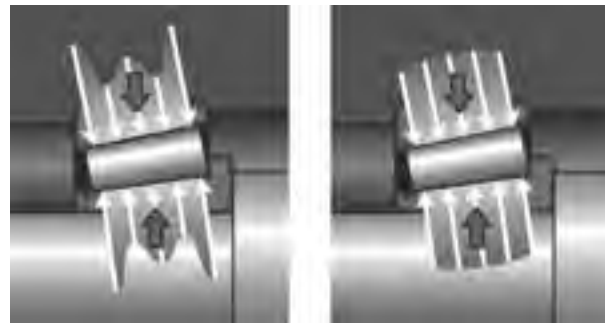

Current Bearing

454-Series

*The bearing is one component of the wheel end system. Please consult your other wheel end (i.e. axle, hub and wheel) suppliers for the rating of their products.*

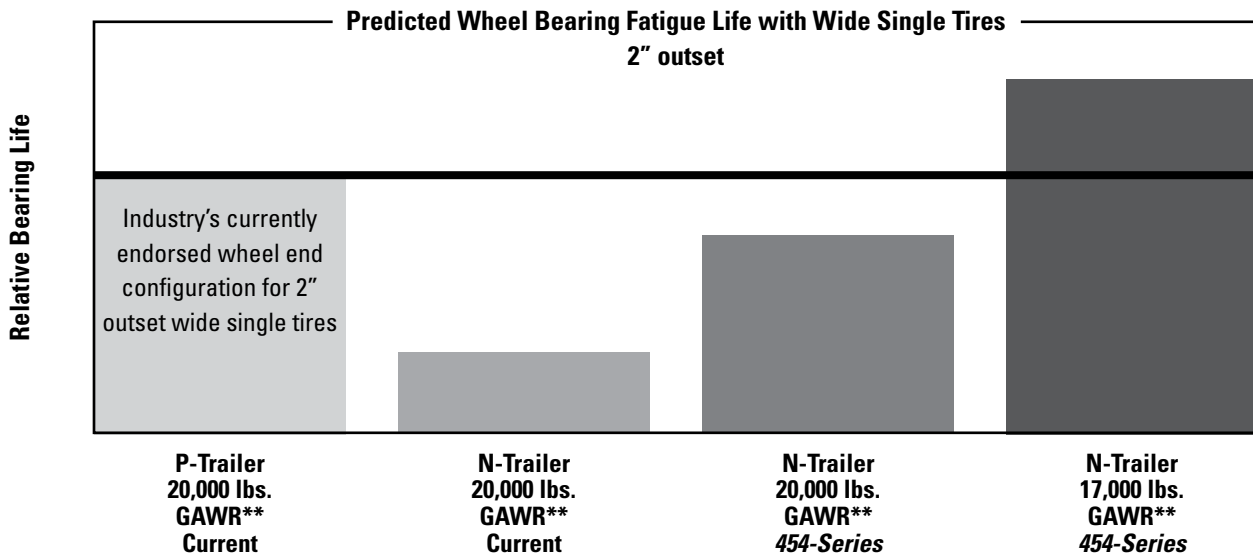

\*\* GAWR - Gross axle weight rating

## ROULEMENTS DE ROUES TIMKEN® 454-SERIES™ POUR VÉHICULES COMMERCIAUX

### Roulements pour pneus jumelés et pneus simples à bande large

- Conçus spécialement pour permettre un déport externe de 2 po.
- Garantissent une certaine cohérence au sein des flottes de transport
- Permettent de combiner différents types de pneus

### Compatibles avec les composants standards de l'industrie

- Peuvent être utilisés avec les essieux et moyeux les plus courants
- Sont compatibles avec l'équipement existant

### Conçus pour améliorer la durée de vie du roulement

- Profils de piste de roulement internes sophistiqués pour une distribution optimale de la charge
- Finis de surfaces améliorés exclusifs

Timken sait que ses clients désirent économiser du carburant, transporter des charges plus lourdes, obtenir des composants

standards et optimiser le temps de service de leurs véhicules commerciaux. Nous avons tenu compte de ces facteurs lors de développement de notre nouvelle gamme de roulements 454-Series™. Les roulements de la gamme 454-Series aident vos flottes de transport à fonctionner de manière plus efficace et rentable.

Depuis plus d'un siècle, Timken fournit des produits de qualité exceptionnelle à l'industrie des poids lourds. La nouvelle gamme de roulement 454-Series continue sur cette lancée en vous offrant, dès aujourd'hui, la technologie des roulements haute performance de demain.

Pour de plus amples informations, veuillez contacter votre représentant de vente Timken ou un des représentants de notre service à la clientèle spécialisé dans l'automobile et les poids lourds au: téléphone (866) 9-TIMKEN (984-6536), ou télécopie (877) TIMKEN-9 (846-5369).

*Profils de piste spéciales et finis de surface améliorés pour une distribution optimale de la charge*

	Cône	Cuvette	Ensemble MileMate®
Remorque N - Ext.	NP454049	NP454011	Set 440
Remorque N - Int.	NP454248	NP454210	Set 441
Essieu Arrière- Ext.	NP454580	NP454572	Set 442
Essieu Arrière- Int.	NP454594	NP454592	Set 443
Remorque P avec châssis intérieur et extérieur	NP454445	NP454410	Set 444

Visitez [www.timken.com/454wheelbearing](http://www.timken.com/454wheelbearing) pour de plus amples informations sur la garantie limitée.

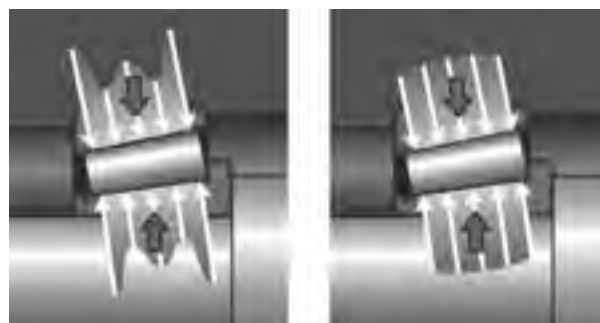

Roulement actuel

454-Series

*Le roulement est une composante du système d'extrémité de roue. Veuillez consulter vos autres fournisseurs de composants d'extrémité de roue (essieu, moyeu et roue) pour obtenir les spécifications de leurs produits.*

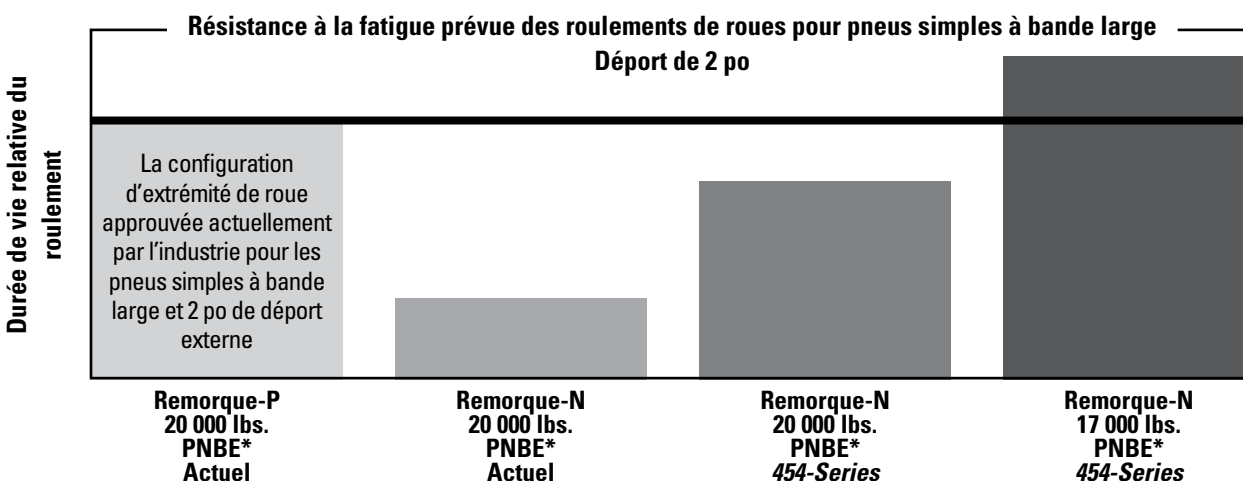

\* PNBE – Poids technique maximal sous essieu

## RODAMIENTOS TIMKEN® 454-SERIES™ PARA RUEDAS DE VEHÍCULOS COMERCIALES

### Rodamientos para rodada doble y sencilla ancha

- Especialmente diseñados para manejar cargas con 2" fuera del centro de la rueda.
- Permiten uniformidad en las flotillas
- Ofrecen flexibilidad en la disposición de las ruedas

### Compatibles con componentes estándar de la industria

- Se pueden usar con diseños populares de ejes y mazas
- Pueden adaptarse a equipos existentes

### Diseñados para maximizar la vida útil del rodamiento

- Perfiles internos de la pista de rodadura de alta ingeniería para una distribución óptima de la carga
- Acabados superficiales mejorados exclusivos de Timken

En Timken, reconocemos la necesidad de tener vehículos comerciales que ahorren combustible, transporten mayores cargas, puedan estandarizarse sus componentes

y optimicen el tiempo productivo. Con esto en mente, nacen los nuevos rodamientos Timken 454-Series™, diseñados para que su flota funcione con mayor eficiencia y mejor relación costo-beneficio.

Con más de 100 años brindando excelencia en la industria automotriz de servicio pesado, las Series-454 de Timken, continúan el legado ofreciéndole hoy, la tecnología del futuro, en sistemas de ruedas de alto rendimiento.

Para mayor información, comuníquese con su representante de ventas Timken o con nuestro equipo de representantes de servicio al cliente de la división automotriz y servicio pesado al teléfono (866) 9-TIMKEN (984-6536), ó por fax al (877) TIMKEN-9 (846-5369).

*Perfiles internos de la pista de rodadura especiales y acabados superficiales mejorados para una óptima distribución de la carga.*

	Cono	Taza	Conjunto MileMate®
N Trailer exterior	NP454049	NP454011	Set 440
N Trailer interior	NP454248	NP454210	Set 441
R Motriz exterior	NP454580	NP454572	Set 442
R Motriz interior	NP454594	NP454592	Set 443
P Trailer interior y exterior	NP454445	NP454410	Set 444

Consulte [www.timken.com/454wheelbearing](http://www.timken.com/454wheelbearing) para obtener información sobre la Garantía limitada.

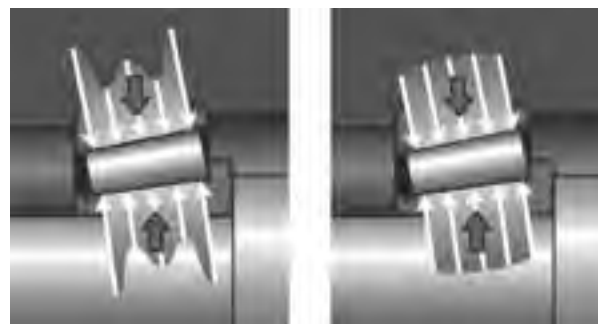

Rodamiento actual

454-Series

*El rodamiento es un componente del sistema del extremo de la rueda. Consulte a sus otros proveedores de componentes para los extremos de las ruedas (es decir, ejes, mazas y ruedas) para conocer las capacidades de sus productos.*

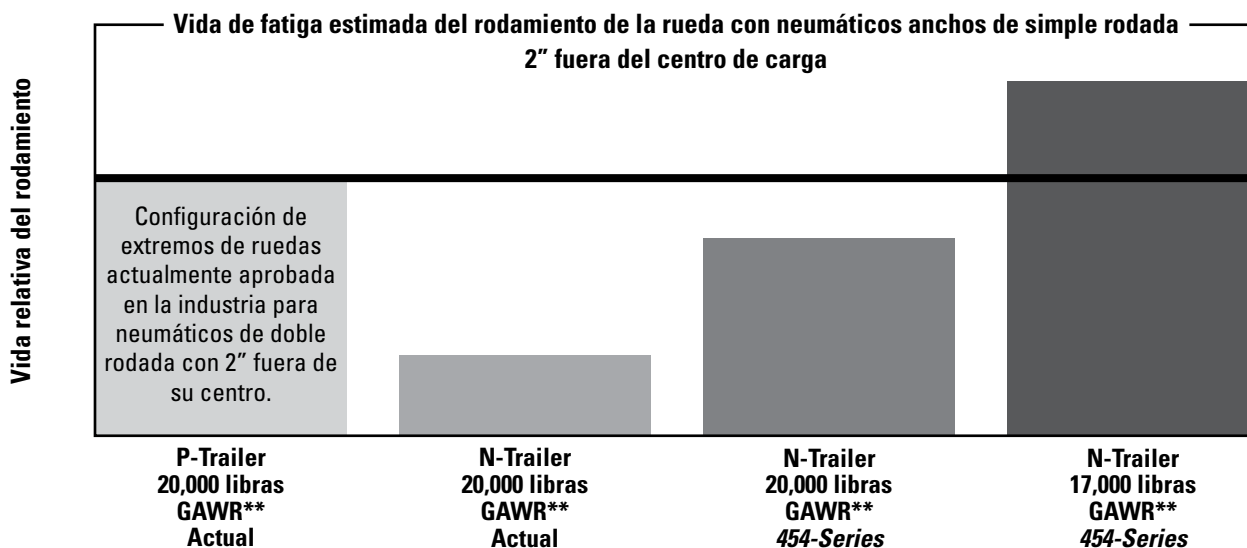

\*\* GAWR – Peso bruto nominal por eje, por sus siglas en inglés

# VEHICLE IDENTIFICATION CHART

Classes 1 & 2 (Under 10,000 lbs.)



PASSENGER VAN



PICKUP



MINI VAN



CARGO VAN

Classes 3, 4, & 5 (10,001-19,500 lbs.)



SHORT-NOSE CONVENTIONAL WITH VAN BODY



CAB FORWARD WITH VAN BODY



LONG WHEEL-BASE WALK-IN VAN



WALK-IN VAN

Class 6 (19,501-26,000 lbs.)



SINGLE AXLE VAN



STAKE



SCHOOL



CDE VAN

Class 7 (26,001-33,000 lbs.)



CDE



TRASH



MEDIUM CONVENTIONAL



FUEL

Class 8 (Over 33,000 lbs.)



CDE



CEMENT



INTERCITY



CONVENTIONAL

# TIMKEN #1 IN COMPARISON TEST

## Tapered Roller Bearings Commonly used in Heavy-Truck Axles and Wheel-Ends

### Setting new standards in bearing life

Since its beginning, Timken has led the industry with significant breakthroughs in bearing technology designed to enhance bearing life. Every Timken® bearing is the result of more than 100 years of experience, knowledge and analysis. This gives us the expertise to explain and, most critically, to analyze and predict bearing life.

While determining bearing life sounds simple enough, it is actually a complex problem that demands a range of technological solutions. At Timken, we have developed highly sensitive tests that help us analyze and validate bearing life.

### Timken case-carburized tapered roller bearings: #1 in comparison test

We originally formulated the case-carburizing process for our alloy steel in 1924 to produce a hard, fatigue-resistant surface and a tough, crack-resistant core. Material composition and microstructure play a significant role in enhancing bearing life. Controlled retained austenite optimizes surface hardness of high-carbon steels and improves surface ductility, resulting in better rolling-contact fatigue life.

We recently tested case-carburized tapered roller bearings commonly used in heavy-truck axles and wheel-ends. All the bearings tested were case-carburized and all are commercially available and produced in North America.

**The result: Timken bearings out-performed all others. The bearing life of the closest competitor was 13% of that of Timken product. In other words, the life of Timken product was more than 7 times longer than that of the closest competitor.**

Are we proud? Absolutely. Surprised? Not a bit. Timken engineers and scientists work around the world continuing the push toward new levels of bearing life.



### Comparison of Bearing Life:

*Case-carburized tapered roller bearings commonly used in heavy-truck axles and wheel-ends*

### Bearing Life Test Results: Median Life Relative to Timken

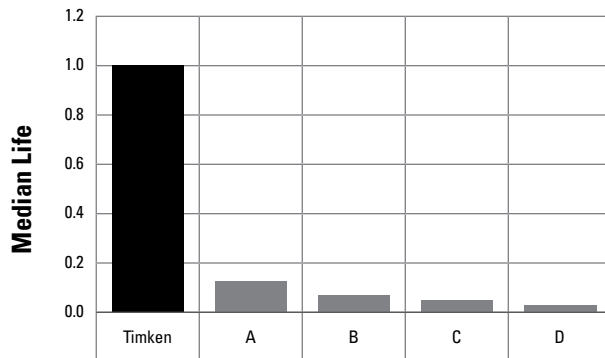

*All the bearings tested\* were case-carburized and all are commercially available and produced in North America. Bearings A, B, C and D are manufactured by top competitors. Information derived from Timken Standard Life Testing, using significant statistical samplings of bearings in a controlled test environment.*

*\*HM212049/011; 594A/592A; 580/572; 575/572; NP840302/NP053874*

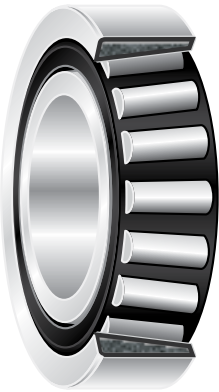

**Factors that can affect tapered roller bearing life**

**Uniform Internal Geometry**

Industry bearing standards set only I.D., O.D., overall bearing width and cup angle of a tapered roller bearing. The angle of contact for cones and rollers varies by brand. Timken internal geometry is uniform and consistent regardless of the plant in which our bearings are manufactured, helping to ensure a perfect match every time. Tight manufacturing tolerances on the cup, cone and rollers help to optimize bearing life.

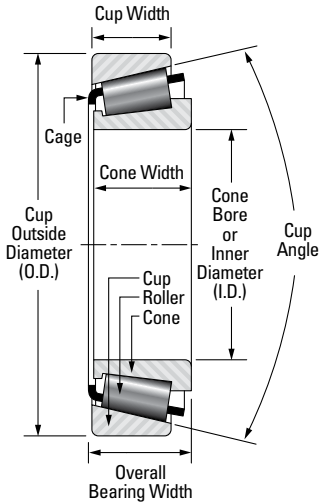

bearing races and rollers. Smoother surface finishes mean less friction and greater efficiency.

**Enhanced Surface Finishes**

We employ advanced finishing processes, which result in more consistent, smoother surface finishes on our

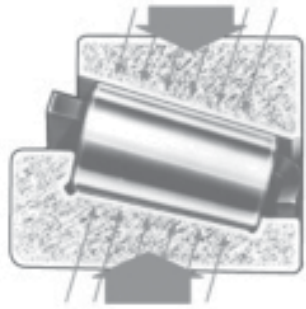

**Special Profiles**

Special profiles reduce stress on Timken bearing races and rollers by providing more even distribution of loads across contact surfaces, increasing load-carrying capacity.

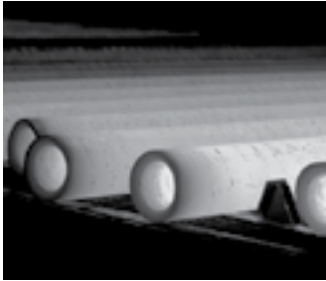

**Steel Quality**

Timken provides customers around the world with high-quality steel. Capitalizing on the synergy between our bearing and steel businesses, we use our

expertise to select bearing materials that meet the most demanding application requirements and help extend bearing life.

**Timken – The Right Choice**

Timken technology offers uniform internal geometry, enhanced surface finishes, special profiles and quality steel to help fleets maximize bearing life. Can your fleet afford downtime associated with lower bearing life?



## TIMKEN, LE N°1 DES TESTS COMPARATIFS

### les roulements à rouleaux coniques couramment utilisés dans les roues et essieux de poids lourds

#### La nouvelle référence pour la durée de vie des roulements

Depuis sa création, Timken fait preuve d'innovation en réalisant des avancées technologiques de premier plan sur la durée de vie des roulements. Chaque roulement Timken® est le fruit de plus d'un siècle d'expérience, de savoir-faire et d'analyses. Nous disposons donc de toute l'expertise pour expliquer et surtout pour analyser et prévoir la durée de vie des roulements.

Contrairement aux apparences, la détermination de la durée de vie d'un roulement est un problème complexe qui fait appel à plusieurs solutions technologiques. Chez Timken, nous avons développé des tests très précis qui nous aident à analyser et à valider cette durée de vie.

#### Roulements à rouleaux coniques en acier cémenté Timken : n°1 des tests comparatifs

Nous avons mis au point le processus de cémentation pour notre alliage d'acier en 1924 afin de produire des pièces dures et résistantes à la fatigue en surface et présentant une grande résistance aux fissures à l'intérieur. La composition et la microstructure du matériau jouent un rôle significatif dans l'augmentation de la durée de vie des roulements. Le contrôle de l'austénite résiduelle optimise la dureté en surface des aciers à teneur élevée en carbone et améliore la ductilité de la surface, entraînant une plus grande résistance à la fatigue des zones en contact. Nous avons récemment testé des roulements à rouleaux coniques en acier cémenté – ceux-là même qui équipent les roues et les essieux des poids lourds. Tous les roulements testés étaient en acier cémenté, et sont commercialisés et fabriqués en Amérique du Nord.

**Le résultat ? Les roulements Timken ont surclassé tous les autres. La durée de vie du roulement classé deuxième était égale à 13 % de celle du produit Timken. Autrement dit, la durée de vie du roulement Timken était 7 fois supérieure à celle de son plus sérieux concurrent.**

Sommes-nous fiers ? Absolument. Surpris ? Pas vraiment. Les ingénieurs et scientifiques Timken travaillent en permanence pour améliorer la durée de vie de nos roulements.



#### Comparaison de la durée de vie des roulements :

*Roulements à rouleaux coniques en acier cémenté, fréquemment utilisés dans les roues et les essieux des poids lourds*

#### Résultats des tests :

##### Durée de vie moyenne par rapport à Timken

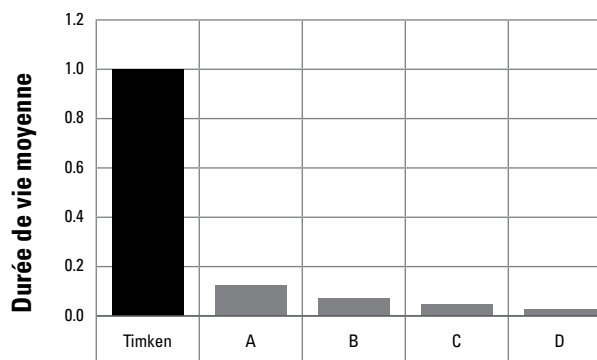

*Tous les roulements testés\* étaient en acier cémenté, et sont commercialisés et fabriqués en Amérique du Nord. Les roulements A, B, C et D sont fabriqués par nos principaux concurrents. Informations obtenues à partir de tests de durée de vie effectués sur des échantillons statistiquement significatifs de roulements en environnement contrôlé.*

*\*HM212049/011 ; 594A/592A ; 580/572 ; 575/572 ; NP840302/NP053874*

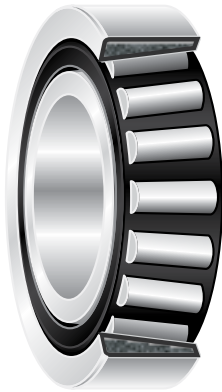

**Facteurs pouvant influencer la durée de vie des roulements à rouleaux coniques**

**Géométrie interne uniforme**

Les standards de l'industrie ne définissent que le diamètre interne, le diamètre externe, la largeur globale et l'angle de cuvette des roulements à rouleaux coniques. L'angle de contact des cônes et des rouleaux varie selon les fabricants. La géométrie interne des roulements Timken est uniforme et cohérente, quel que soit le site de production, ce qui garantit des produits parfaits. Les tolérances

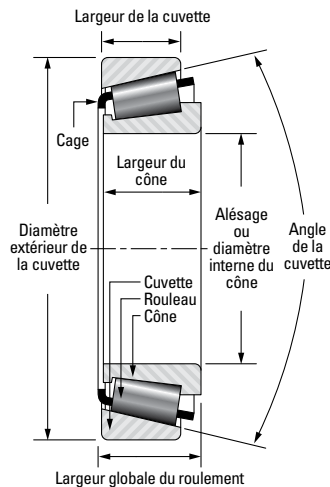

de fabrication – très strictes – de la cuvette, du cône et des roulements optimisent la durée de vie des roulements.



de fabrication – très strictes – de la cuvette, du cône et des roulements optimisent la durée de vie des roulements.

**États de surfaces améliorés**

Nos processus de finition très perfectionnés génèrent des surfaces plus lisses et plus cohérentes sur nos rouleaux et nos bagues de roulement. La qualité de la finition de surface diminue les frictions et garantit une plus grande efficacité.

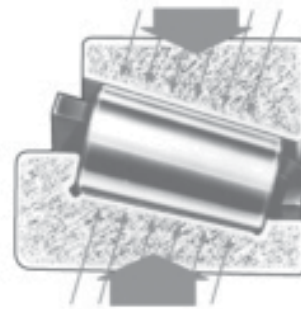

**Profils spéciaux**

Les profils spéciaux réduisent les contraintes sur les rouleaux et les bagues de roulement Timken en répartissant mieux les contraintes sur les surfaces en contact, augmentant la capacité de charge.

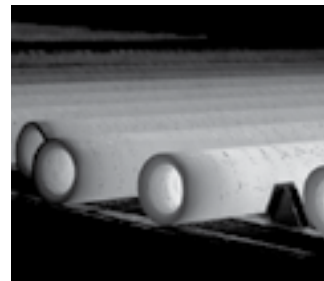

**Qualité de l'acier**

Timken fournit des aciers de grande qualité à des clients dans le monde entier. Grâce à la synergie entre nos activités Acier et Roulements, nous

mettons à profit notre expertise pour sélectionner des matériaux qui répondent aux conditions d'utilisation les plus exigeantes et aident à prolonger la durée de vie des roulements.

**Timken – Le bon choix**

La technologie Timken garantit une géométrie interne uniforme, des états de surface de meilleure qualité, des profils spéciaux et un acier performant qui aident à optimiser la durée de vie des roulements utilisés sur les poids lourds. Tirez le meilleur parti de votre parc de véhicules avec roulements à durée de vie élevée !



# TIMKEN, N.º 1 EN LA PRUEBA DE COMPARACIÓN

## Rodamientos de rodillos cónicos usados generalmente en ejes y ruedas de camiones para servicio pesado

### Estableciendo estándares en la vida de los rodamientos

Desde sus inicios, Timken ha encabezado la industria con avances tecnológicos significativos, encaminados a optimizar la vida útil de los rodamientos. Cada rodamiento de Timken® es el resultado de más de 100 años de experiencia, conocimiento y análisis; lo que nos capacita para explicar y, lo más crítico, analizar y predecir la vida de un rodamiento.

Aunque determinar la vida útil de los rodamientos parece bastante simple, en realidad se trata de un problema complejo que requiere de una serie de procesos técnicos. En Timken, hemos desarrollado pruebas de alta sensibilidad que nos permiten analizar y validar la vida útil de los rodamientos.



### Rodamientos cementados de rodillos cónicos Timken: #1 en la prueba de comparación

Originalmente, en 1924, formulamos el proceso de cementado del acero aleado para obtener una superficie dura y resistente a la fatiga, y un centro blando y resistente a los impactos. La composición del material y su microestructura juegan un papel muy importante en la mejora de la vida útil del rodamiento. El control de la austenita retenida optimiza la dureza de la superficie de los aceros al alto carbón y mejora su ductilidad, resultando en mayor vida útil de las superficies de contacto. Recientemente, sometimos a prueba los rodamientos cementados de rodillos cónicos usados generalmente en ejes y ruedas de camiones de servicio pesado. Todos los rodamientos evaluados eran cementados y se fabrican y comercializan en Norteamérica.

**El resultado: los rodamientos de Timken superaron a todos los demás. El competidor que logró el mejor rendimiento después de Timken, registró el 13% de la vida útil de nuestros rodamientos. En otras palabras, la vida útil del producto de Timken superó siete veces a la del competidor más cercano.**

¿Nos enorgullece? Por supuesto. ¿Nos sorprende? Para nada. Los ingenieros y científicos de Timken trabajan en todo el mundo para alcanzar nuevos niveles en la vida útil de los rodamientos.

### Comparación de la vida útil de los rodamientos:

*Rodamientos cementados de rodillos cónicos utilizados generalmente en ejes y ruedas de camiones de servicio pesado.*

### Resultados de la Prueba de Vida Útil de los rodamientos: Vida media en relación a Timken

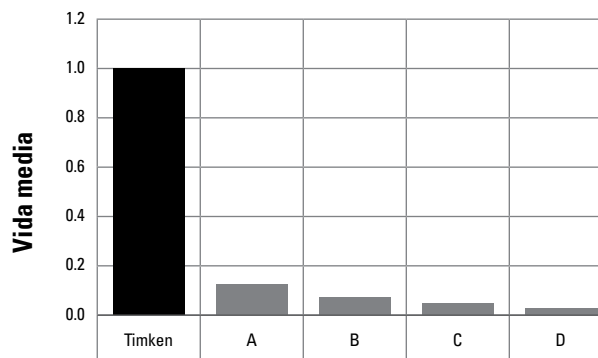

*Todos los rodamientos evaluados\* eran cementados y se fabrican y comercializan en Norteamérica. Los rodamientos A, B, C y D son fabricados por los competidores más importantes. La información se extrajo de las Pruebas Estándar de Vida Útil de Timken, mediante un importante muestreo estadístico de rodamientos en un entorno de prueba controlado.*

*\*HM212049/011; 594A/592A; 580/572; 575/572; NP840302/NP053874*

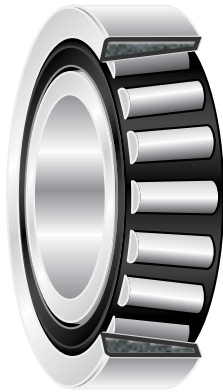

**Factores que pueden afectar la vida útil de los rodamientos de rodillos cónicos**

**Geometría interna uniforme**

Los estándares de la industria para los rodamientos establecen sólo el diámetro interior (DI), el diámetro exterior (DE), el ancho total del rodamiento y el ángulo de taza del rodamiento cónico. El ángulo de contacto de conos y rodillos varía según la marca. La geometría interna de los rodamientos de Timken es uniforme y consistente, sin importar la planta en la que se fabriquen. Lo que garantiza

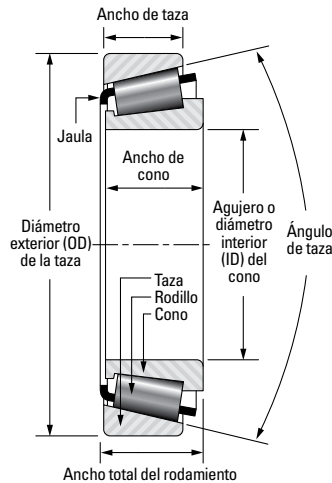

siempre un acople perfecto. Las cerradas tolerancias de fabricación en la taza, el cono y los rodillos ayudan a optimizar la vida útil del rodamiento.



rodillos de los rodamientos. Los acabados de superficie más lisos brindan menor fricción y mayor eficiencia.

**Acabados mejorados de superficie**

Tenemos procesos avanzados de acabado que logran superficies más uniformes y lisas en los anillos guía y los

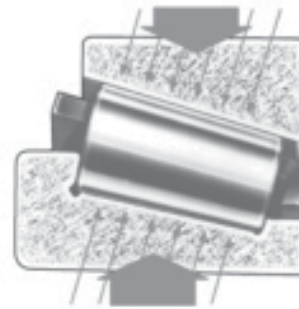

**Perfiles especiales**

Los perfiles especiales reducen la tensión en los anillos guía de los rodamientos de Timken al proporcionar una distribución de cargas más uniforme en las superficies de contacto,

lo que se traduce en una mayor capacidad de transporte de carga.

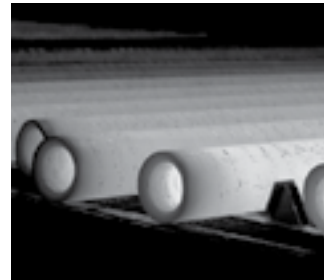

**Calidad del acero**

Timken provee acero de alta calidad a clientes de todo el mundo. Aprovechamos la sinergia entre nuestros negocios de rodamientos y de acero:

utilizamos nuestra experiencia para seleccionar materiales para los rodamientos que cumplan con los requisitos de las aplicaciones más exigentes y contribuyan a prolongar la vida útil de los rodamientos.

**Timken: la selección correcta**

La tecnología Timken ofrece una geometría interna uniforme, acabados de superficie mejorados, perfiles especiales y acero de alta calidad para maximizar la vida útil de los rodamientos de las flotillas. ¿Puede su flotilla tolerar tiempos muertos asociados a menor vida útil de los rodamientos?



# TAPERED ROLLER BEARING DAMAGE ANALYSIS



The most common types of bearing damage that may result in a reduction of bearing or application life are often caused by:

- insufficient maintenance practices
- mishandling
- improper installation and adjustment practices
- inadequate lubrication

The following offers a quick reference to the common causes of bearing damage.

## Fatigue Spalling

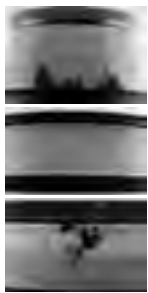

Geometric stress concentration: Spalling from misalignment, deflections or heavy loading.

Inclusion origin: Spalling from oxides or other hard inclusions in bearing steel.

Point surface origin: Spalling from debris or raised metal exceeding the lubricant film thickness.

## Foreign Material



Abrasive wear: Fine abrasive particle contamination.

Bruising: Debris from other fatigued parts, inadequate sealing or poor maintenance.

Grooving: Large particle contamination embedding into soft cage material.

## Inadequate Lubrication\*



Roller end scoring: Metal-to-metal contact from breakdown of lubricant film.



Cone large rib face scoring: 'Welding' and heat damage from metal-to-metal contact.



Cone large rib face deformation: Metal flow from excessive heat generation.



Total bearing lock-up: Rollers skew, slide sideways and lock-up bearing.

**\* Excessive preload can cause damage similar to inadequate lubrication damage.**

## Corrosion/Etching



Staining: Surface stain with no significant corrosion from moisture exposure.



Etching: Rusting with pitting and corrosion from moisture/water exposure.



Line spalling: Roller spaced spalling from bearings operating after etching damage.

## False Brinelling

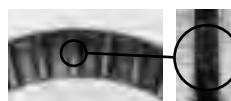

Wear caused by vibration or relative axial movement between rollers and races.

**Handling Damage**

Roller spaced nicking: Raised metal on races from contact with roller edges.

Roller nicking/denting: Rough handling or installation damage.

Cup-face denting: Indentations from hardened driver.

**Cage Damage**

Cage Deformation: Improperly installed or dropped bearing.

Rollers binding and skewing: Cage ring compressed during installation or interference during service.

**Misalignment**

Irregular roller path from deflection, inaccurate machining or wear of bearing seats.

**Peeling**

Micro-spalling due to thin lubricant film from high loads/low RPM or elevated temperatures.

**High Spots In Cup Seats**

Localized spalling on the cup race from stress riser created by split housing pinch point.

**Improper Fit**

Cone bore damage: Fractured cone due to out-of-round or oversized shaft.

Cup spinning: Loose cup fit in a rotating wheel hub.

**Excessive Preload Or Overload**

Rapid and deep spalling caused by unusually high stresses. Full race width fatigue spalling is caused by heavy loads creating a thin lubricant film and elevated temperatures.

**True Brinelling**

Damage from shock or impact.

**Electric Current**

Electric arc pitting: Small burns created by arcs from improper electric grounding while the bearing is stationary.

Fluting: Series of small axial burns caused by electric current passing through the bearing while it is rotating.

**Excessive End Play**

Scalloping: Uneven localized wear resulting from excessive end play.

Cage pocket wear: Heavy contact between the rollers and cage pocket surfaces caused by bearing operating too loosely.

**⚠️ WARNING** Failure to observe the following warnings could create a risk of serious bodily harm.

Proper maintenance and handling practices are critical. Failure to follow installation instructions and to maintain proper lubrication can result in equipment failure.

Never spin a bearing with compressed air. The rolling elements may be forcefully expelled.

## TIMKEN HEAVY-DUTY TECHTIPS – FREE RESOURCE

The Timken Company offers a series of technical information called Heavy-Duty TechTips. Professional technicians, as well as counter and sales people, appreciate the easy access to Timken product knowledge

TechTips provides installation and maintenance information for Timken® hubs, bearings, seals and components to help maximize their life and performance, and the systems in which they operate.

Visit [www.timken.com/techtips](http://www.timken.com/techtips) and print your own reference copies of existing issues of TechTips. You can also sign up to receive future issues electronically.



# TIMKEN TECH SERIES FREE ONLINE TECH TRAINING TOOL

Timken invites you to take advantage of our Tech Series Training and Resource Tool.

Featuring sections on our full lines of Timken® hub unit bearings, tapered roller bearings, seals, needle and cylindrical bearings, ball bearings and lubricants, our Web tool is a storehouse of information and an invaluable asset! It incorporates insightful video, helpful photos and provides thorough explanations that are easy to follow.

All product sections contain learning opportunities on various subjects including basics, troubleshooting, removal, installation and damage analysis, in addition to many other useful resources. All the sections include a testing chapter in which users can apply their product knowledge, earn product certification patches and receive corresponding certificates of completion. Tests can be completed online, via e-mail, fax or registered mail.

So go ahead, start your intellectual engines, and view the entire contents of Tech Series FREE online at [www.timken.com/techseries/](http://www.timken.com/techseries/)

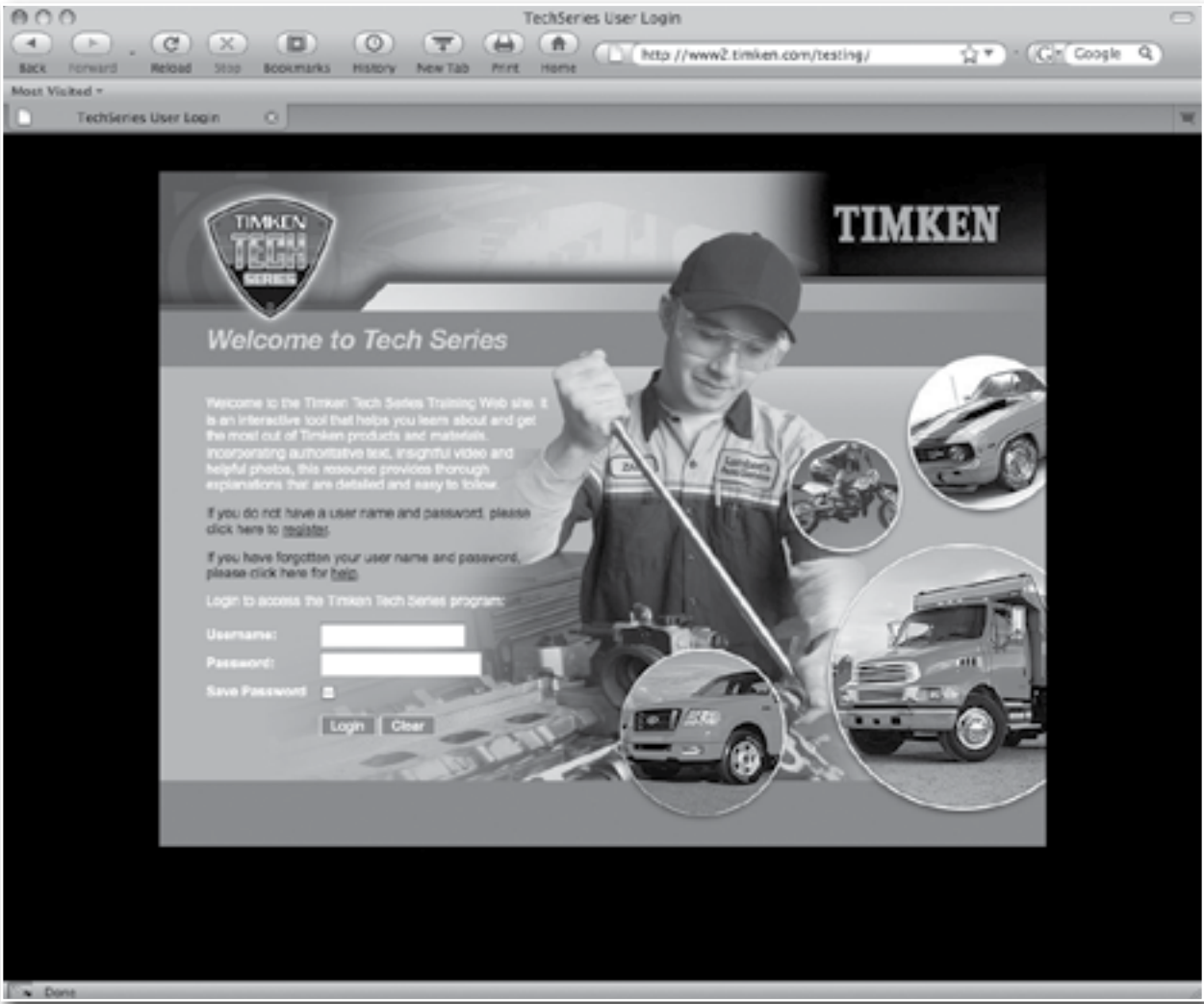











US \$10

## PRODUCT OFFERING

### HUB UNIT BEARINGS

- ABS Hub Unit Bearings
- ABS Hub Unit Bearings with SENSOR-PAC™ Bearings
- Non-ABS Hub Unit Bearings
- Non-ABS Hub Unit Bearings with UNIPAC™ Bearings
- Non-ABS Hub Unit Bearings with UNIPAC-PLUS™ Bearings

### BEARINGS

- Ball Bearings
- Clutch Release Bearings
- Cylindrical Bearings
- Cylindrical Axle Repair Bearings
- Driveline Center Support Bearings
- Needle Bearings
- Tapered Bearings

### SEALS

- Automotive
- Industrial
- Light- and Heavy-Duty Oil Bath Seals
- Metric

### SPECIALTY KITS

- DT Components® Drivetrain Products
- Differential Kits
- Transaxle & Transfer Case Kits
- Transmission Kits
- KWIK-SLEEVES™ Shaft Repair Kits
- MileMate® Matched Wheel Bearing Sets
- Set-Right™ Heavy-Duty Hub Rebuild Kits
- Automotive Wheel Bearing Grease
- Sensor Kits
- Trailer Kits with Standard Bearings



**TIMKEN**  
Where You Turn

[www.timken.com](http://www.timken.com)

Timken® is the registered trademark of  
The Timken Company.

The registered and unregistered trademarks in this  
catalog are the property of their respective owners.

© 2009 The Timken Company  
Printed in U.S.A.  
30M 05-09-29 Order No. 7002